



Mount Triumph

Model # 1701014

Wooden Swing Set

Owner's Manual & Assembly Instructions

MANUFACTURED BY:
Backyard Discovery
3305 Airport Drive
Pittsburg, KS 66762
800-856-4445



INSTALLATION SERVICES AVAILABLE!*

Need a helping hand?

Let our team of professionals handle the installation for you!

GOCONFIGURE
888-888-5424

*Installation services are only available to U.S. customers.

average 2 person assembly time

INTERMEDIATE
10
HOURS

assembly time may vary based on skill level

Before you begin

FOR QUICK & EASY ASSEMBLY

FIND 3D INSTRUCTIONS FOR THIS PRODUCT IN

BILT.

DOWNLOAD THE FREE APP



For the most up to date assembly manual, to register your set, or to order replacement parts please visit

www.backyarddiscovery.com

SAVE THIS ASSEMBLY MANUAL FOR FUTURE REFERENCE IN THE EVENT THAT YOU NEED TO ORDER REPLACEMENT PARTS.

Para obtener instrucciones en español, visite www.backyarddiscovery.com



GOCONFIGURE
Putting it all together for you

INSTALLATION SERVICES AVAILABLE!*

Need a helping hand?

Let our team of professionals handle the installation for you!

GOCONFIGURE
888-888-5424

**Installation services are only available
to U.S. customers.*

With Go Configure, we bring you 18 years of experience right to your doorstep. We service a wide array of indoor and outdoor recreation products that most consumers don't have the time or ability to deliver & install themselves.

We do the heavy lifting, so you don't have to!

- 18+ Years of Experience Servicing Big Box Retailers and Direct Consumers
- Highly Skilled, Specialized, Courteous, Professional Service Technicians
- Over 140,000 Installations Annually
- White Glove Service

- Satisfaction Guarantee
- Flexible Appointments, including weekends
- Coverage across the nation

Visit www.goconfigure.com for more info!

**Installation services are only available to U.S. customers.*



The store where you made your purchase does not stock parts for this item.

If you have assembly questions or you are missing or have damaged parts, please call

1-800-856-4445

you can also visit www.backyarddiscovery.com
or e-mail customerservice@backyarddiscovery.com

Please have the following information ready when you make your call:

- Model Number of the product located on the front of the assembly manual
 - Description of the part from the parts list
-
- Read entire assembly manual, paying special attention to the important tips and safety information.
 - Ensure there are no missing pieces by first separating and identifying all parts.
 - Make sure to check packing material for small parts that may have fallen out during shipment.
 - Structures are not intended for public use. The Company does not warranty any of its residential structures subjected to commercial use such as: Daycare, Preschool, Nursery School, Recreational Park, or any similar Commercial Application.
 - This manual contains helpful information concerning assembly preparation, installation procedure and required maintenance.
 - Always keep safety in mind as your structure is being built.
 - Keep these instructions for future reference.



Please read entire booklet completely before beginning the assembly process

Please retain these instructions and your receipt for future reference. Keep them in a safe place where you can refer to them as needed. In order to provide you with the most efficient service, it is required that you provide us with the part numbers when ordering parts.

For Your Records:

Please take time and fill out the information below. This information will be needed for warranty issues.

Where Purchased: _____
 Date of Purchase: _____
 Installation Date: _____
 Installed by: _____
 Tracking Number: _____

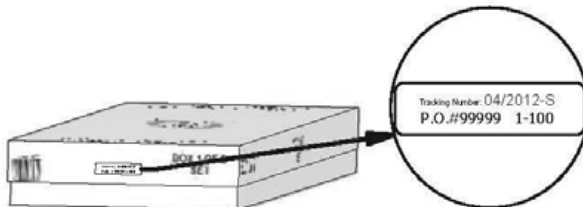
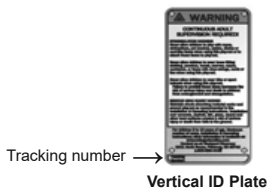

Tracking Number Reference Label

Tracking ID number on the carton and on the bottom of the vertical ID plate are included for tracking purposes associated with warranty claims.

This Limited Warranty by Backyard Discovery applies to products manufactured under the Backyard Discovery brand or its other brands including but not limited to Backyard Botanical, Adventure Playsets, and Leisure Time Products.

Backyard Discovery warrants that this product is free from defect in materials and workmanship for a period of one (1) year from the original date of purchase. This one (1) year warranty covers all parts including wood, hardware, and accessories. All wood carries a five (5) year pro-rated warranty against rot and decay. Refer to the schedule below for charges associated with replacement of parts under this Limited Warranty. In addition, Backyard Discovery will replace any parts within the first 30 days from date of purchase found to be missing from or damaged in the original packaging.

This warranty applies to the original owner and registrant and is non-transferable. Regular maintenance is required to assure maximum life and performance of this product. Failure by the owner to maintain the product according to the maintenance requirements may void this warranty. Maintenance guidelines are provided in the Owner's Manual.

This Limited Warranty does not cover:

- Labor for any inspection
- Labor for replacement of any defective item(s)
- Incidental or consequential damages
- Cosmetic defects which do not affect performance or integrity of a part or the entire product
- Vandalism, improper use, failure due to loading or use beyond the capacities stated in the applicable Assembly Manual.
- Acts of nature including but not limited to wind, storms, hail, floods, excessive water exposure
- Improper installation including but not limited to installation on uneven, unlevel, or soft ground
- Minor twisting, warping, checking, or any other natural occurring properties of wood that do not affect performance or integrity

Backyard Discovery products have been designed for safety and quality. Any modifications made to the original product could damage the structural integrity of the unit leading to failure and possible injury. Modification voids any and all warranties and Backyard Discovery assumes no liability for any modified products or consequences resulting from failure of a modified product.

This product is warranted for RESIDENTIAL USE ONLY. Under no circumstance should a Backyard Discovery product be used in public settings. Such use may lead to product failure and potential injury. Any and all public use will void this warranty. Backyard Discovery disclaims all other representations and warranties of any kind, express or implied.

Pro Rated Part Replacement Schedule

<u>Product Age</u>	<u>Customer Pays</u>
All Parts	
0-30 days from date of purchase	\$0 and free shipping
31 days to 1 year	\$0 + S&H
Wood Rot and Decay Only	
1 year	\$0 and free shipping
2 year	20% + S&H
3 year	40% + S&H
4 year	60% + S&H
5 year	80% + S&H
Over 5 years	100% + S&H



NOTE:

Your Children's Safety Is Our #1 Concern!

Observe the following statements and warnings to reduce the likelihood of serious or fatal injury. Please review these safety rules regularly with your children.



WARNING: BURN HAZARD

- Pay special attention to plastic and metal surfaces as they may be hot enough to cause burns.
- Always check the temperature of the product before letting your children play on it.
- Remember that the product may cause burns if left in direct sunlight.
- Always be aware of the sun and weather conditions, and do not assume that the equipment is safe because the air temperature is not very high.

- Children **MUST NOT** use this playcenter until unit has been completely assembled and inspected by an adult to ensure set has been properly installed and anchored.
- Equipment is recommended for use by children 3 to 10 years of age.
- This Playcenter is designed for specific number of occupants whose combined weight should not exceed the designated weight on the elevated floor or the swing area. The total unit capacity is outlined in the Basic Setup Dimensions section of instruction manual. The maximum fall height and recommended play area is also available in the Basic Setup Dimensions section of the manual for the specific unit.
- On-site, continuous adult supervision is **REQUIRED**. **MOST SERIOUS INJURIES AND DEATHS ON PLAYGROUND EQUIPMENT HAVE OCCURRED WHILE CHILDREN WERE UNSUPERVISED!**
- **DO NOT** allow children to walk close to, in front of, behind, or between moving swings or other moving playground equipment.
- **DO NOT** let children stand on swings.
- Children should **NOT** twist the chains and ropes and should not loop them over the top support bar, this could reduce the strength of the chain or rope.
- **DO NOT** let children push empty seats. The seat could hit them and cause serious injury.
- Instruct and teach children to sit in the center of the swings with their full weight on the seats.
- **DO NOT** allow children to use the equipment in a manner other than intended.
- Instruct children **NOT** to get off equipment while it is in motion.
- Instruct children to **ALWAYS** go down slides feet first. Never slide head first.
- Instruct children to **LOOK** before they slide to make sure no one is at the bottom.
- **DO NOT** allow children to run up a slide, as this increases their chances of falling.
- **DRESS CHILDREN APPROPRIATELY.** (Examples would include wearing well-fitting shoes and the avoidance of ponchos, scarfs, and other loose-fitting clothing that is potentially hazardous while using equipment).
- **DO NOT** allow children to climb when the equipment is wet.
- Children should **NEVER** jump from a fort deck. They should always use the ladder, ramp or slide.
- Children should **NEVER** be allowed to crawl or walk across the top of monkey bars.
- **DO NOT** allow children to crawl on top of a fort roof.
- Verify that any suspended climbing ropes, chain, or cable are secured at both ends and that they cannot be looped back on themselves as to create an entanglement hazard.
- **DO NOT** let children attach items to the playground equipment that are not specifically designed for use with the equipment. Items such as, but not limited to, jump ropes, clothesline, pet leashes, cables and chain can cause a strangulation hazard.
- Children should **NEVER** wrap their legs around swing chain.
- **DO NOT** allow children to slide down the swing chain.
- Instruct children to remove their bike or other sports helmet before playing on playground equipment.
- **NEVER** add extra length to chain or rope. The chains or ropes provided are the maximum length designed for the swinging element(s).



Positioning Your Playcenter

- The playcenter is designed to be installed on a level surface by an adult with an adult helper. Place in a flat area of your yard to minimize ground preparation.
- Choose a level location for the equipment. This can reduce the likelihood of the play set tipping over and loose-fill surfacing material washing away during heavy rains.
- Place the equipment not less than 6 ft (1.8 m) from any structure or obstruction such as a fence, garage, house, overhanging branches, laundry lines, or electrical wires.
- Provide enough room so that the children can use the equipment safely. For example, for structures with multiple play activities, a slide should not exit in front of a swing.
- It is a good idea to place your playcenter in an area that is convenient for adults to watch children at play.
- Create a site free of obstacles that could cause injuries – such as low overhanging tree branches, overhead wires, tree stumps and/or roots, large rocks, bricks and concrete. Additional suggestions in the Suggested Playground Surfacing Section.
- Do not build your playset on top of surfacing material.
- Locate bare metal platforms and slides out of direct sunlight to reduce the likelihood of serious burns. A slide that faces north will receive the least direct sunlight.
- Separate active and quiet activities from each other. For example, locate sandboxes away from swings or use a guardrail or barrier to separate the sandbox from the movement of the swings.

Suggested Playground Surfacing

- Do not install home playground equipment over concrete, asphalt, packed earth, grass, carpet, or any other hard surface. A fall onto a hard surface can result in serious injury to the equipment user.
- Do not install loose fill surfacing over hard surfaces such as concrete or asphalt.
- Shredded bark mulch, wood chips, fine sand and fine gravel, are added as shock absorbing materials after assembly. If used properly these materials can absorb some of the impact of a child's fall.
- All surface material should extend a minimum of 6ft (1.8m) feet in all directions around the play area.
- Do not apply playground surfacing until after the unit is completely constructed. Playset should not be built on top of surfacing.
- Use containment, such as digging out around the perimeter and/or lining the perimeter with landscape edging.
- Installations of rubber tiles or poured-in-place surfaces (other than loose-fill materials) generally require a professional and are not "do-it-yourself" projects.
- Shall use Playground Surfacing Materials (other than loose-fill material) which comply with the safety standard ASTM F1292 Standard Specification of Impact Attenuation of Surfacing Materials within the Use Zone of Playground Equipment.

The following chart explains the fall height in feet from which a life threatening head injury would not be expected

Critical Heights in feet (m) of Tested Materials

Material	Uncompressed Depth			Compressed Depth to 9" (228mm)
	6" (152mm)	9" (228mm)	12" (304mm)	
Wood Chips	7' (2.13m)	10-12' (3.0-3.6m)	11' (3.35m)	10' (3.05m)
Double-Shredded Bark Mulch	6' (1.83m)	10-12' (3.0-3.6m)	11' (3.35m)	7' (2.13m)
Engineered Wood Fibers	6' (1.83m)	7' (2.13m)	>12' (3.66m)	6' (1.83m)
Fine Sand	5' (1.52m)	5' (1.52m)	9' (2.74m)	5' (1.52m)
Coarse Sand	5' (1.52m)	5' (1.52m)	6' (1.83m)	4' (1.22m)
Fine Gravel	5' (1.52m)	7' (2.13m)	10' (3.05m)	6' (1.83m)
Medium Gravel	5' (1.52m)	5' (1.52m)	6' (1.83m)	5' (1.52m)
Shredded Tires*	10-12' (3.0-3.6m)	N/A	N/A	N/A

*This data is from tests conducted by independent testing laboratories on a 6-inch depth of uncompressed shredded tire samples produced by four manufacturers. The tests reported critical heights, which varied from 10 feet to greater than 12 feet. It is recommended that persons seeking to install shredded tires as a protective surface request test data from the supplier showing the critical height of the material when it was tested in accordance with ASTM F1292.



APPENDIX A

The following information is from the United States Consumer Product Safety Commission's Information Sheet for playground surfacing material; also see the following website for additional information: www.cpsc.gov

X3. SECTION 4 OF THE CONSUMER PRODUCT SAFETY COMMISSION'S OUTDOOR HOME PLAYGROUND SAFETY HANDBOOK⁹

X3.1 Select Protective Surfacing—One of the most important things you can do to reduce the likelihood of serious head injuries is to install shock-absorbing protective surfacing under and around your play equipment. The protective surfacing should be applied to a depth that is suitable for the equipment height in accordance with ASTM Specification F 1292. There are different types of surfacing to choose from; whichever product you select, follow these guidelines:

X3.1.1 Loose-Fill Materials:

X3.1.1.1 Maintain a minimum depth of 9 inches of loose-fill materials such as wood mulch/chips, engineered wood fiber (EWF), or shredded/recycled rubber mulch for equipment up to 8 feet high; and 9 inches of sand or pea gravel for equipment up to 5 feet high. NOTE: An initial fill level of 12 inches will compress to about a 9-inch depth of surfacing overtime. The surfacing will also compact, displace, and settle, and should be periodically refilled to maintain at least a 9-inch depth.

X3.1.2 Use a minimum of 6 inches of protective surfacing for play equipment less than 4 feet in height. If maintained properly, this should be adequate. (At depths less than 6 inches, the protective material is too easily displaced or compacted.)

NOTE: Do not install home playground equipment over concrete, asphalt, or any other hard surface. A fall onto a hard surface can result in serious injury to the equipment user. Grass and dirt are not considered protective surfacing because wear and environmental factors can reduce their shock absorbing effectiveness. Carpeting and thin mats are generally not adequate protective surfacing. Ground level equipment such as a sandbox, activity wall, playhouse or other equipment that has no elevated play surface – does not need any protective surfacing.

X3.1.3 Use containment, such as digging out around the perimeter and/or lining the perimeter with landscape edging. Don't forget to account for water drainage.

X3.1.3.1 Check and maintain the depth of the loose-fill surfacing material. To maintain the right amount of loose-fill materials, mark the correct level on play equipment support posts. That way you can easily see when to replenish and/or redistribute the surfacing.

X3.1.3.2 Do not install loose-fill surfacing over hard surfaces such as concrete or asphalt.

X3.1.4 Poured-In-Place Surfaces or Pre-Manufactured Rubber Tiles — You may be interested in using surfacing other than loose-fill materials – like rubber tiles or poured-in-place surfaces.

X3.1.4.1 Installations of these surfaces generally require a professional and are not “do-it-yourself” projects.

X3.1.4.2 Review surface specification before purchasing this type of surfacing. Ask the installer/manufacture for a report showing that the product has been tested to the following safety standard: ASTM F 1292 Standard Specification for Impact Attenuation of Surfacing Materials within the Use Zone of Playground Equipment. This report should show the specific height for which the surface is intended to protect against serious head injury. This height should be equal to or greater than the fall height – vertical distance between a designated play surface (elevated surface for standing, sitting, or climbing) and the protective surfacing below – of your play equipment

X3.1.4.3 Check the protective surfacing frequently for wear.

X3.1.5 Placement — Proper placement and maintenance of protective surfacing is essential. Be sure to:

X3.1.5.1 Extend surfacing at least 6 feet from the equipment in all directions.

X3.1.5.2 For to-fro swings, extend protective surfacing in front of and behind the swing to a distance equal to twice the height of the top bar from which the swing is suspended.

⁹This information has been extracted from the CPSC publications “Playground Surfacing — Technical Information Guide” and “Handbook for Public Playground Safety.” Copies of these reports can be obtained by sending a postcard to the: Office of Public Affairs, U.S. Consumer Product Safety Commission, Washington, D.C., 20207 or call the toll-free hotline: 1-800-638-2772.

The American Society for Testing and Materials takes no position respecting the validity of any parent right asserted in connection with any item mentioned in this standard. Users of this standard are expressly advised that determination of the validity of any such parent rights, and the risk of infringement of such rights, are entirely their own responsibility.

The standard is subject to revision at any time by the responsible technical committee and must be reviewed every five years and if not revised, either approved or withdrawn. Your comments are invited either for revision of this standard or for additional standards and should be addressed to ASTM Headquarters. Your comments will receive careful consideration at a meeting of the responsible technical committee, which you may attend. If you feel that your comments have not received a fair hearing you should make your views known to the ASTM Committee on Standards. 100 Barr Harbor Drive, West Conshohocken, PA 19428.



IT IS IMPORTANT TO CHECK AND TIGHTEN ALL HARDWARE AT THE BEGINNING AND DURING THE SEASON AS THEY MAY LOOSEN DUE TO WOOD EXPANSION AND CONTRACTION.

At the beginning of each play season

- Tighten all hardware.
- Lubricate all metallic moving parts per manufacturer's instructions.
- Check all protective coverings on bolts, pipes, edges, and corners. Replace if they are loose, cracked, or missing.
- Check all moving parts including swing seats, ropes, cables, and chains for wear, rust, or other deterioration. Replace as needed.
- Check metal parts for rust. If found, sand and repaint using a non lead-based paint meeting the requirements of 16 CFR 1303.
- Check all wood members for deterioration and splinters. Sand down splinters and replace deteriorating wood members.
- Reinstall any plastic parts, such as swing seats or any other items that were removed for the cold season.
- Rake and check depth of loose fill protective surfacing materials to prevent compaction and to maintain appropriate depth. Replace as necessary.

Twice a month during play season

- Tighten all hardware.
- Check all protective coverings on bolts, pipes, edges, & corners. Replace if they are loose, cracked, or missing.
- Rake and check depth of loose fill protective surfacing materials to prevent compaction and to maintain appropriate depth. Replace as necessary.

Once a month during play season.

- Lubricate all metallic moving parts per manufacturer's instructions.
- Check all moving parts including swing seats, ropes, cables, and chains for wear, rust, or other deterioration. Replace as needed.

At the end of each season or when the temperature drops below 32° F

- Remove plastic swing seats and other items as specified by the manufacturer and take indoors or do not use.
- Rake and check depth of loose fill protective surfacing materials to prevent compaction and to maintain appropriate depth. Replace as necessary.

Additional Maintenance

- Check the swing beam and hardware every two weeks due to wood expansion and contraction. It is particularly important that this procedure be followed at the beginning of each season.
- Inspect wood parts monthly. The grain of the wood sometimes will lift in the dry season causing splinters to appear. Light sand may be necessary to maintain a safe playing environment. Treat your playset with stain regularly, to help prevent severe checking/splitting and other weather damage.
- A waterborne transparent stain has been applied to your playset. This is done for color only. Once or twice a year, depending on your climate conditions, you must apply some type of protection (sealant) to the wood of your unit. Prior to the application of sealant, lightly sand any "rough" spots on your playset. Please note this is a requirement of your warranty.
- Assembling and maintaining the playset on a level location is very important. As your children play, your playset will slowly dig its way into the soil, and it is very important that it settles evenly. Make sure the playset is level and true one each year or at the beginning of each play season.

Disposal Instructions

When the Playcenter use is no longer desired, it should be disassembled and disposed of in such a way that no unreasonable hazards will exist at the time the unit is discarded.

Third Party Assembly

Customer may, in their sole discretion, elect to use a third party person or service to assemble this product. Backyard Discovery assumes no responsibility or liability for any charge incurred by the Customer for any assembly services'. Please see our warranty for more information about damaged and missing part replacement coverage. Backyard Discovery will not reimburse Customer for the price of parts purchased.

OWNERS SHALL BE RESPONSIBLE FOR MAINTAINING THE LEGIBILITY OF THE WARNING LABELS



Your Backyard Discovery structure is designed and constructed of quality materials. As with all outdoor products it will weather and wear. To maximize the enjoyment, safety and life of your structure it is important that you properly maintain it.

About Our Wood

Backyard Discovery uses 100% Cedar (C. Lanceolata) wood. Although we take great care in selecting the best quality lumber available, wood is still a product of nature and susceptible to weathering which can change the appearance of your set.

What causes weathering? Does it affect the strength of my product?

One of the main reasons for weathering is the effects of water (moisture); the moisture content of the wood at the surface is different than the interior of the wood. As the climate changes, moisture moves in or out of the wood, causing tension which can result in checking and or warping. You can expect the following due to weathering. These changes will not affect the strength of the product:

1. Checking is surface cracks in the wood along the grain. A post (4" x 4") will experience more checking than a board (1" x 4") because the surface and interior moisture content will vary more widely than in thinner wood.

2. Warping results from any distortion (twisting, cupping) from the original plane of the board and often happens from rapid wetting and drying of the wood.

3. Fading happens as a natural change in the wood color as it is exposed to sun-light and will turn grey over time.

How can I reduce the amount of weathering to wood product?

1. Your wood product is coated with a water-based stain. Sunlight will break down the coating, so we recommend applying a water repellent or stain on a yearly basis (see your local stain and paint supplier for a recommended product). You must apply some type of protection (sealant) to the wood of your product. **Please note this is a requirement of your warranty.** Most weathering is just the normal result of nature and will not affect safety. However if you are concerned that a part has experienced a severe weathering problem please call our customer service department for further assistance.

2. Inspect wood parts monthly. The grain of the wood sometimes will lift in the dry season causing splinters to appear. Light sanding may be necessary to maintain a safe environment. Treating your Product with protection (sealant) after sanding will help prevent severe checking/splitting and other weather damage.



Protrusion Hazard

Incorrect

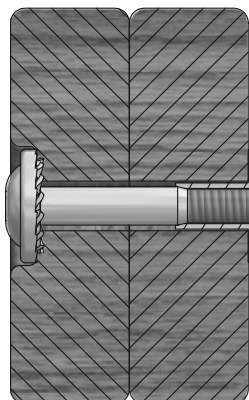

If you see exposed threads and your bolt protrudes beyond the T-Nut you may have over tightened the bolt or used incorrect hardware. If you've overtightened, remove the bolt and add washers to eliminate the protrusion.

Correct

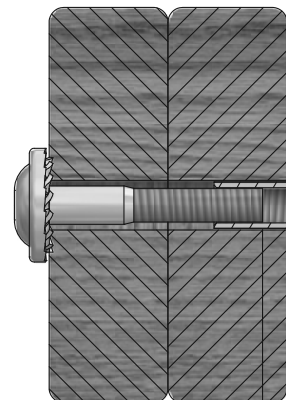

1/8"

Proper Hardware Assembly

Bolt and T-Nut Assembly

Tap T-nut into the provided hole. Insert your bolt through the lock washer and insert into the provided hole opposite from the T-Nut. Turn clockwise to thread into T-nut. Do not completely tighten until instructed.

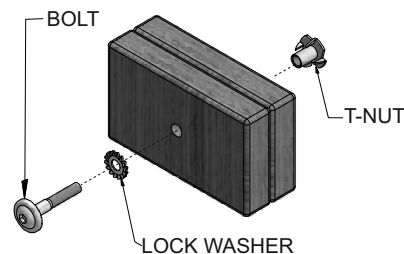

Bolt and Barrel Nut Assembly

Insert barrel nut through the lock washer and press the pair through the provided hole. Insert your bolt through the second lock washer and insert the pair into the provided hole opposite from the barrel nut. Turn clockwise to thread into the barrel nut. Do not completely tighten until instructed.

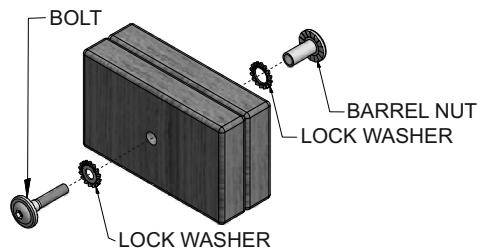

Lag Assembly

Normally there will be a pre-drilled pilot hole on assemblies that require a Lag Screw. If there is no pilot hole, line up the two boards as they are to be attached and use the factory drilled hole as a guide to drill another pilot hole into the adjoining board. This will keep the wood from splitting. Only a lock washer is required for steps with Lag Screws.

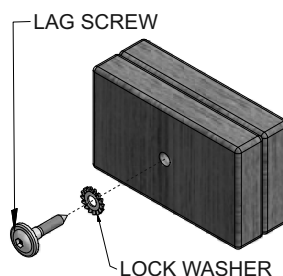



ASSEMBLY TIP:

Keep an eye out for these boxes which will contain helpful pictures and information making the assembly process as quick and painless as possible.

Sorting Wood

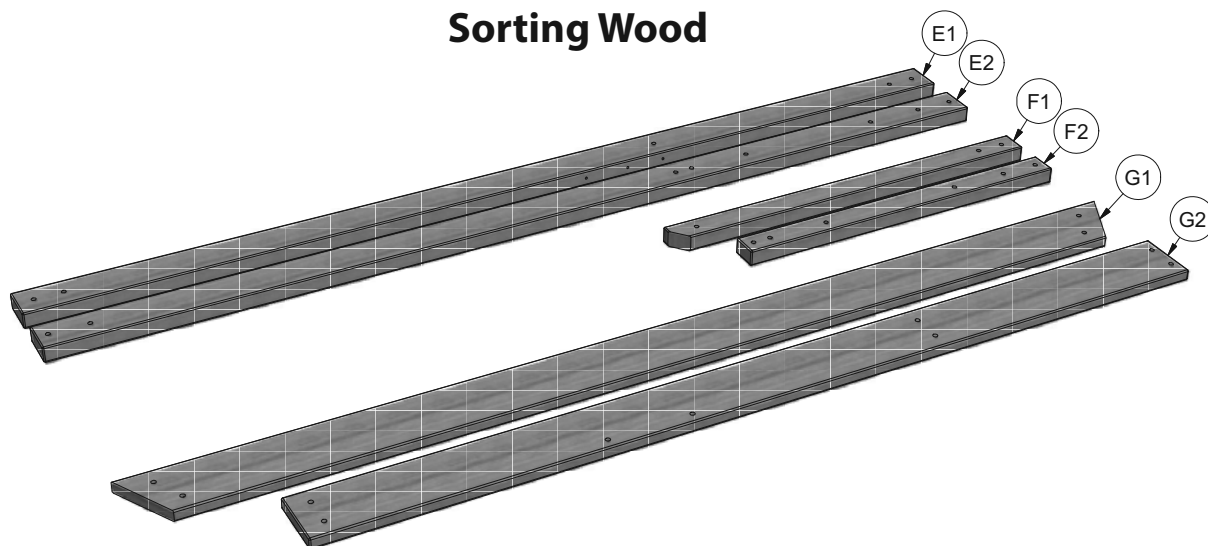

When removing the wood from the boxes we recommend arranging them by part number before you begin assembly. This will allow for faster assembly and easily identify any parts that may be missing or damaged.

Sorting Hardware

NUT BARREL
H100545



SCREW
H100695

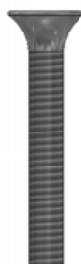

T-NUT
H100699

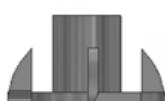

WASHER FLAT
H100706



BOLT HEX
H100716

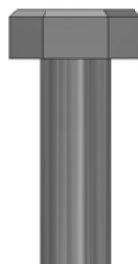

BOLT
H100718



SCREW PWH
H100742

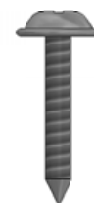

To help with assembly we recommend sorting your hardware bags with the seven digit alpha-numeric number printed on the bags or by hardware type (i.e. bolts, nuts, etc.). Organizing your hardware will make assembly easier.

Hardware Identification

Hardware bags are printed with a seven digit alpha-numeric part number. During assembly you only need to reference the last three digits of the part number as noted in each step. This will make finding the correct hardware easier.

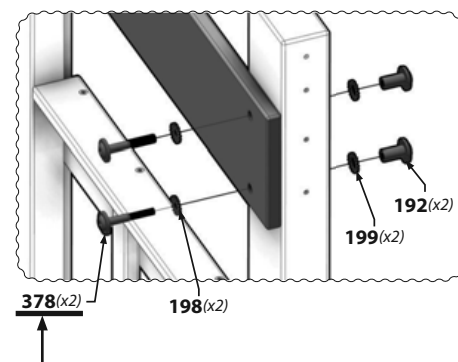
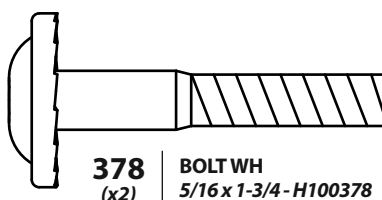

Tools Required for Installation:

(These are the tools that are generally required for assembly of our outdoor products. These tools are not included with the outdoor product purchase.)

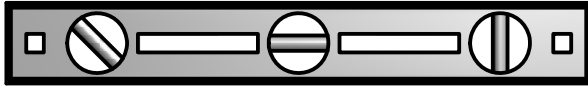

(Level 24")

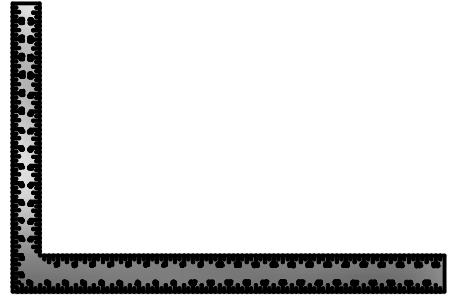

(Square)



(Phillips Screw Driver)



(Open End Wrenches 1/2")



(Tape Measure)



(Claw Hammer)



(Rubber Mallet - Optional)

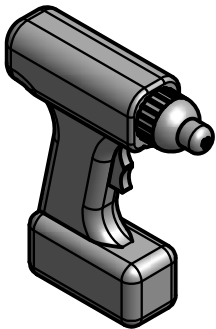

(Cordless Drill or Electric Drill)



(Drill Attachments: Phillips Head)

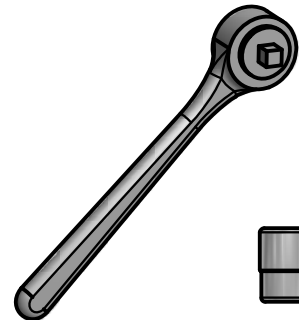

(3/8" Drive Ratchet, 1/2" STD Sockets 1/2" Deep Sockets)



(An Adult w/ an Adult Helper)



(Ladder)



(1/8" & 7/16" Drill Bits)

Basic Setup Dimensions

Place the set on level ground, not less than 6 ft [2 m] from any structure or obstruction such as a fence, garage, house, overhanging branches, laundry lines, or electrical wires.

General Information:

Your set has been designed and engineered for children only and for residential use only. A maximum of 150 lbs. per child is recommended for play activities designed for individual use.

A maximum of 120 lbs. per child is recommended for play activities designed for multiple child use.

A maximum of 9 children is recommended for this swing set.

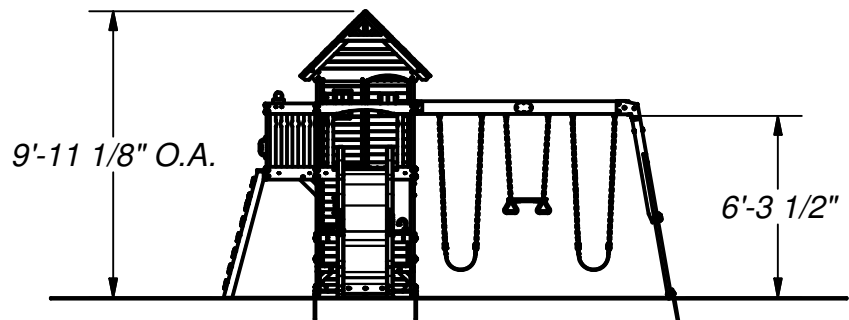
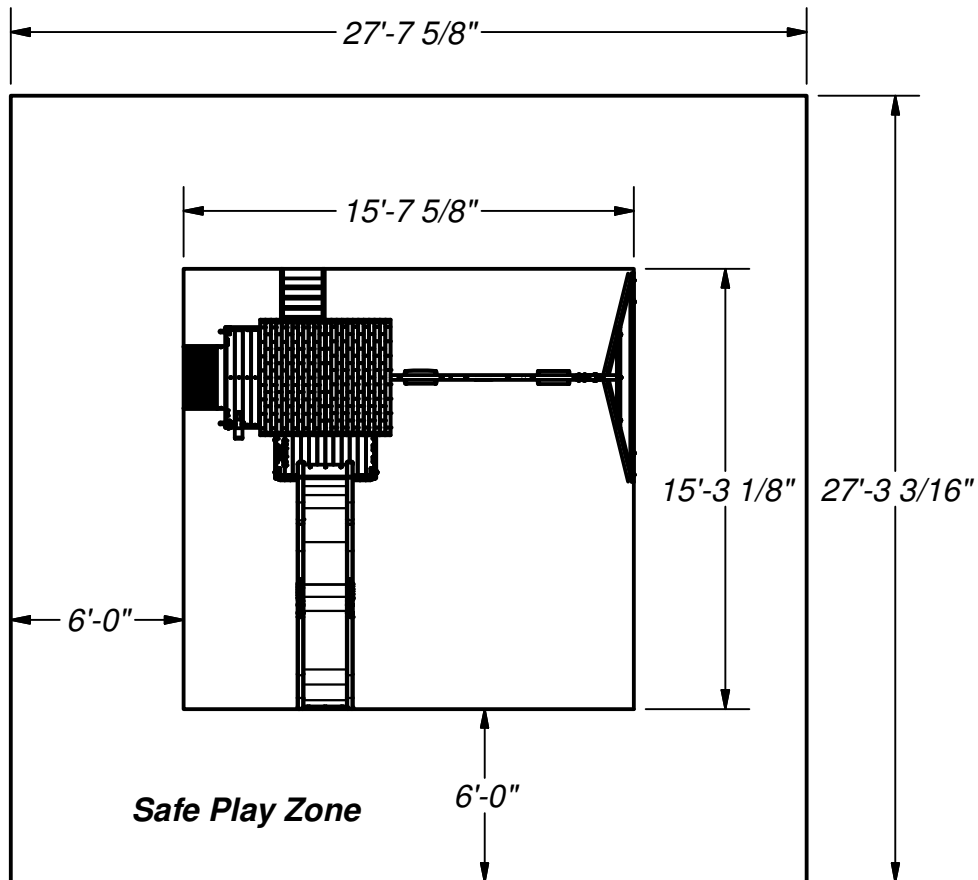

Important Assembly Notes

Safe play height: 15'-11 1/8" [4.7 m]
Maximum fall height: 6'-3 1/2" [1.8 m]

- 1) While assembling unit, take time before and after each phase to make sure fort is level. If fort is not level, assembly will be difficult and improper assembly may result. Extra care must be taken to ensure the fort is square.
- 2) Tighten bolts securely, tighten nuts on bolts flush to the tube or member.
- 3) Pay close attention to the ITEMS NEEDED FOR EACH PHASE. They can be a valuable aid when sorting your wood and hardware. Assembly will be made easier if items are sorted by phase.
- 4) Pay close attention to make sure you are using the correct hardware in the correct phases. Using incorrect hardware may result in improper assembly.
- 5) Whenever a T-nut is used, follow these directions. Place T-nut in pre-drilled hole. Tap in with hammer. Place bolt with washers in the opposite side. Hand tighten to make sure the bolt is in the T-nut. DO NOT over tighten.
- 6) Read the steps of each phase thoroughly. The written steps may include important information not shown in the illustrations.

Parts Identification

Wood Components

(NOT TO SCALE)



(1) **E1 - RIGHT REAR UPRIGHT - W2A02080**
1 3/8"x3 3/8"x51 3/4" (36x86x1314)



(1) **E2 - LEFT REAR UPRIGHT - W4L07493**
1 3/8"x3 3/8"x51 3/4" (36x86x1314)



(1) **E3 - LEFT FRONT UPRIGHT - W4L07494**
1 3/8"x3 3/8"x51 3/4" (36x86x1314)



(1) **E4 - RIGHT FRONT UPRIGHT - W4L07495**
1 3/8"x3 3/8"x51 3/4" (36x86x1314)



(1) **E5 - RIGHT FRONT BALCONY UPRIGHT - W4L07502**
1 3/8"x3 3/8"x80 3/4" (36x86x2052)



(1) **E6 - LEFT REAR UPRIGHT - W4L07509**
1 3/8"x3 3/8"x43 1/2" (36x86x1104)



(1) **E7 - RIGHT REAR UPRIGHT - W4L07510**
1 3/8"x3 3/8"x43 1/2" (36x86x1104)



(1) **E8 - LEFT FRONT UPRIGHT - W4L07511**
1 3/8"x3 3/8"x43 1/2" (36x86x1104)



(1) **E9 - RIGHT FRONT UPRIGHT - W4L07512**
1 3/8"x3 3/8"x43 1/2" (36x86x1104)



(2) **E10 - MOUNTING BLOCK - W4L07615**
1 3/8"x3"x4 3/4" (36x76x120)



(1) **E11 - RIGHT FRONT BALCONY UPRIGHT - W4L07673**
1 3/8"x3 3/8"x80 3/4" (36x86x2052)

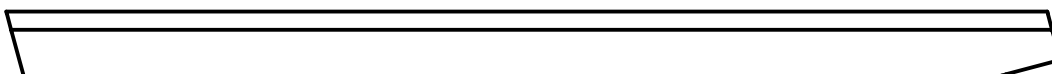

(1) **E72 - LEFT RAIL - W4L07622**
1 3/8"x3 3/8"x54 7/8" (36x86x1395)

Parts Identification

Wood Components

(NOT TO SCALE)

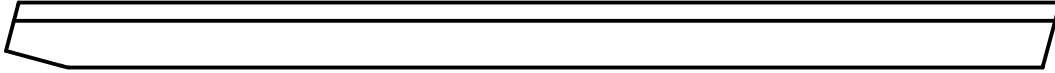

- (1) **E73 - RIGHT RAIL - W4L07623**
1 3/8"x3 3/8"x54 7/8" (36x86x1395)



- (2) **E77 - ANGLE BRACE - W4L07631**
1 3/8"x3 3/8"x74 3/8" (36x86x1890)



- (1) **F1 - RIGHT BALCONY UPRIGHT - W4L07506**
1 3/8"x2 3/8"x31 3/4" (36x60x805)



- (1) **F2 - LEFT BALCONY UPRIGHT - W4L07507**
1 3/8"x2 3/8"x31 3/4" (36x60x805)



- (1) **F3 - SUPPORT BLOCK - W4L07604**
1 3/8"x2 3/8"x5 7/8" (36x60x148)



- (1) **F4 - SUPPORT BLOCK - W4L07614**
1 3/8"x2 3/8"x5 7/8" (36x60x148)



- (1) **G1 - SWING BEAM MOUNT - W4L07513**
1"x5 1/4"x62 1/8" (24x134x1577)



- (1) **H1 - TABLE SUPPORT - W4L07583**
1"x3 3/8"x22 3/8" (24x86x567)

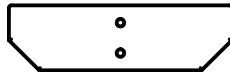

- (1) **H2 - TABLE SUPPORT - W4L07584**
1"x3 3/8"x11 5/8" (24x86x295)



- (1) **H3 - TABLE SUPPORT - W4L07585**
1"x3 3/8"x11 5/8" (24x86x295)



- (4) **H4 - DECK BRACE - W4L07616**
1"x3 3/8"x12 3/4" (24x86x325)

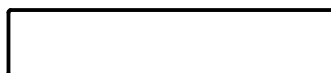

- (4) **H76 - LADDER RUNG - W4L07620**
1"x3 3/8"x17 1/4" (24x86x437)

Parts Identification

Wood Components

(NOT TO SCALE)



- (1) **H77 - LEFT UPRIGHT - W4L07617**
1"x3 3/8"x58" (24x86x1474)



- (1) **H78 - RIGHT UPRIGHT - W4L07618**
1"x3 3/8"x58" (24x86x1474)

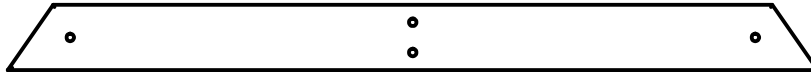

- (1) **H79 - END SUPPORT - W4L07632**
1"x3 1/2"x42" (24x86x1072)



- (1) **H80 - GROUND BOARD - W4L07630**
1"x3 3/8"x87 3/8" (24x86x2218)



- (1) **J1 - PORCH GROUND BOARD - W4L07504**
1"x2 3/8"x40 1/2" (24x60x1030)



- (1) **J2 - PORCH GROUND BOARD - W4L07505**
1"x2 3/8"x40 5/8" (24x60x1032)



- (2) **J3 - BENCH SUPPORT - W4L07586**
1"x2 3/8"x9" (24x60x230)



- (2) **J4 - ANGLE BRACE - W4L07587**
1"x2 3/8"x10" (24x60x254)



- (2) **J5 - SUPPORT BLOCK - W4L07588**
1"x2 3/8"x2 7/8" (24x60x72)



- (2) **J6 - SUPPORT BLOCK - W4L07589**
1"x2 3/8"x6 1/4" (24x60x160)



- (1) **J7 - SUPPORT BLOCK - W4L07595**
1"x2 3/8"x3 3/8" (24x60x86)



- (1) **J8 - FLOOR JOIST - W4L07602**
1"x2 3/8"x40 1/2" (24x60x1029)

Parts Identification

Wood Components

(NOT TO SCALE)



- (1) **J9 - FLOOR JOIST - W4L07603**
1"x2 3/8"x20 1/4" (24x60x513)

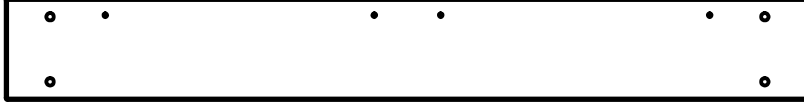

- (1) **K1 - GROUND BOARD - W4L07489**
5/8"x5 1/4"x41 7/8" (16x134x1064)

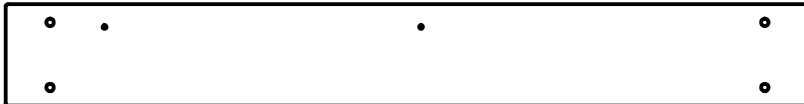

- (1) **K2 - GROUND BOARD - W4L07490**
5/8"x5 1/4"x41 7/8" (16x134x1064)

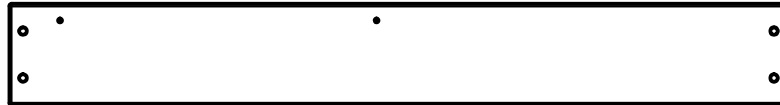

- (1) **K3 - GROUND BOARD - W4L07491**
5/8"x5 1/4"x40 1/2" (16x134x1030)

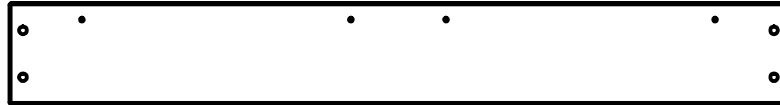

- (1) **K4 - GROUND BOARD - W4L07492**
5/8"x5 1/4"x40 1/2" (16x134x1030)



- (1) **K5 - RIGHT CENTER WALL RAIL - W4L07496**
5/8"x5 1/4"x62 3/4" (16x134x1593)

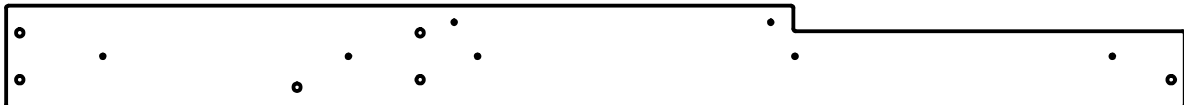

- (1) **K6 - FRONT CENTER WALL RAIL - W4L07497**
5/8"x5 1/4"x61 3/8" (16x134x1560)



- (1) **K7 - REAR CENTER WALL RAIL - W4L07498**
5/8"x5 1/4"x61 3/8" (16x134x1560)

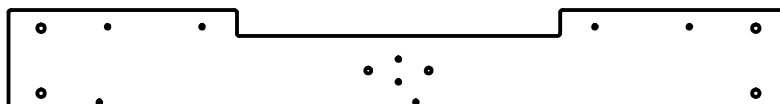

- (1) **K8 - LEFT CENTER WALL RAIL - W4L07499**
5/8"x5 1/4"x40 5/8" (16x134x1032)

Parts Identification

Wood Components

(NOT TO SCALE)



(1) **K9 - LEFT BALCONY WALL RAIL - W4L07500**
5/8"x5 1/4"x20 3/4" (16x134x528)

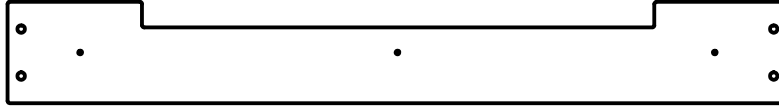

(1) **K10 - FRONT BALCONY WALL RAIL - W4L07501**
5/8"x5 1/4"x40 5/8" (16x134x1032)

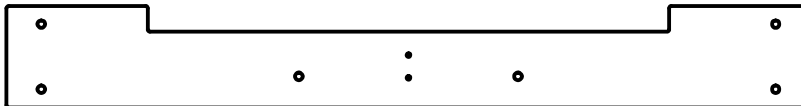

(1) **K11 - LEFT SIDE WALL BOARD - W4L07508**
5/8"x5 1/4"x41 7/8" (16x134x1064)



(1) **K12 - ARCHED WALL RAIL - W4L07579**
5/8"x5 1/4"x40 5/8" (16x134x1032)



(1) **K13 - ARCHED WALL RAIL - W4L07580**
5/8"x5 1/4"x40 5/8" (16x134x1032)

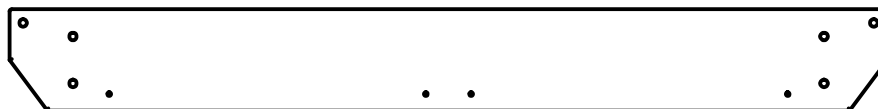

(1) **K14 - ANGLED WALL RAIL - W4L07581**
5/8"x5 1/4"x45 3/4" (16x134x1162)



(1) **K15 - ANGLED WALL RAIL - W4L07582**
5/8"x5 1/4"x45 3/4" (16x134x1162)

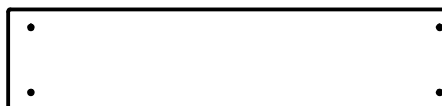

(1) **K16 - TABLE BOARD - W4L07594**
5/8"x5 1/4"x23" (16x134x583)

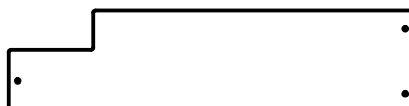

(2) **K17 - FLOOR BOARD - W4L07596**
5/8"x5 1/4"x21 1/8" (16x134x537)

Parts Identification

Wood Components

(NOT TO SCALE)



- (1) **L1 - ARCHED WALL RAIL - W4L07514**
5/8"x4 3/8"x40 5/8" (16x112x1032)



- (1) **L2 - WALL RAIL - W4L07515**
5/8"x4 3/8"x22 7/8" (16x112x582)

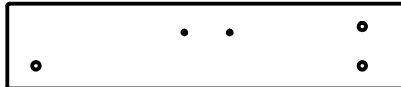

- (1) **L3 - WALL RAIL - W4L07576**
5/8"x4 3/8"x20 7/8" (16x112x529)

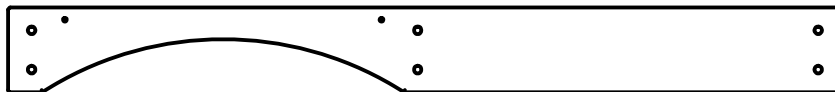

- (1) **L4 - ARCHED WALL RAIL - W4L07577**
5/8"x4 3/8"x43 1/2" (16x112x1106)



- (1) **L5 - ARCHED WALL RAIL - W4L07578**
5/8"x4 3/8"x40 5/8" (16x112x1032)

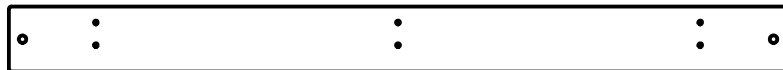

- (1) **M1 - WALL RAIL - W4L07590**
5/8"x3 3/8"x40 1/2" (16x86x1030)



- (2) **M2 - BENCH BOARD - W4L07591**
5/8"x3 3/8"x23" (16x86x583)



- (4) **M3 - TABLE BOARD - W4L07593**
5/8"x3 3/8"x23" (16x86x583)



- (8) **M4 - FLOOR BOARD - W4L07597**
5/8"x3 3/8"x21 1/8" (16x86x537)



- (1) **M5 - FLOOR BOARD - W4L07598**
5/8"x3 3/8"x19 1/4" (16x86x488)

Parts Identification

Wood Components

(NOT TO SCALE)



(1) **M6 - COUNTER TOP - W4L07605**
5/8"x3 3/8"x37 5/8" (16x86x957)



(1) **M7 - COUNTER TOP - W4L07606**
5/8"x3 3/8"x38 5/8" (16x86x981)



(1) **M8 - FLOOR BOARD - W4L07607**
5/8"x3 3/8"x20 1/8" (16x86x512)



(10) **M9 - FLOOR BOARD - W4L07608**
5/8"x3 3/8"x20 1/8" (16x86x512)



(1) **M10 - FLOOR BOARD - W4L07609**
5/8"x3 3/8"x40 5/8" (16x86x1031)

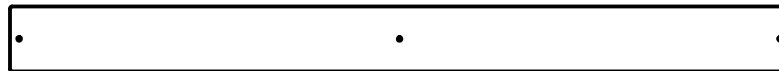

(15) **M11 - FLOOR BOARD - W4L07610**
5/8"x3 3/8"x40 5/8" (16x86x1031)

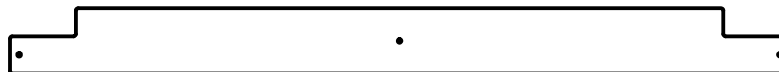

(2) **M12 - FLOOR BOARD - W4L07611**
5/8"x3 3/8"x40 5/8" (16x86x1031)



(1) **M13 - FLOOR BOARD - W4L07671**
5/8"x3 3/8"x20 1/8" (16x86x512)



(1) **M70 - SLIDE BED SUPPORT - W100935**
5/8"x3 3/8"x19 7/8" (16x86x505)



(1) **M73 - REAR SUPPORT - W4L07619**
5/8"x3 3/8"x18 1/4" (16x86x465)



(8) **M74 - ROCK WALL BOARD - W4L07624**
5/8"x3 3/8"x25" (16x86x635)

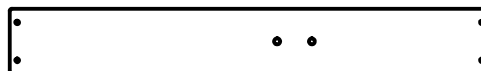

(4) **M75 - ROCK WALL BOARD - W4L07627**
5/8"x3 3/8"x25" (16x86x635)

Parts Identification

Wood Components

(NOT TO SCALE)



- (4) **M76 - ROCK WALL BOARD - W4L07626**
5/8"x3 3/8"x25" (16x86x635)



- (1) **M102 - ATTACHMENT BOARD - W4L07628**
5/8"x3 3/8"x26 1/4" (16x86x667)



- (1) **M108 - TOP BOARD - W4L07625**
5/8"x3 3/8"x26 1/4" (16x86x667)



- (1) **M110 - ATTACHMENT BOARD - W4L07621**
5/8"x3 3/8"x18 1/4" (16x86x465)



- (2) **N1 - PORCH GROUND BOARD - W4L07503**
5/8"x2 3/8"x21 1/8" (16x60x537)



- (18) **N2 - PICKET - W4L07612**
5/8"x2 3/8"x24 3/4" (16x60x628)



- (2) **N3 - BENCH BOARD - W4L07592**
5/8"x2 3/8"x23" (16x60x583)

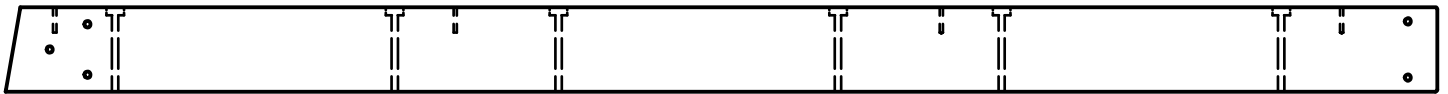

- (1) **SB74 - SWING BEAM EXTENDED - W4L07633**
2"x5 1/4"x89 1/2" (50x134x2274)



- (3) **T1 - SUPPORT BOARD - W4L07599**
1"x1 3/8"x37 5/8" (24x34x957)



- (1) **T2 - SUPPORT BOARD - W4L07600**
1"x1 3/8"x37 3/4" (24x34x959)



- (2) **T3 - SUPPORT BOARD - W4L07601**
1"x1 3/8"x18 3/4" (24x34x477)

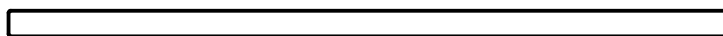

- (1) **T4 - SUPPORT BOARD - W4L07613**
1"x1 3/8"x37 3/4" (24x34x958)

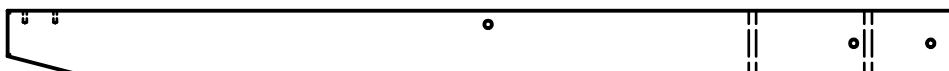

- (1) **W71 - SWING BEAM SUPPORT - W4L07629**
2"x3 3/8"x49 5/8" (50x86x1260)

Parts Identification

Wood Components

(NOT TO SCALE)

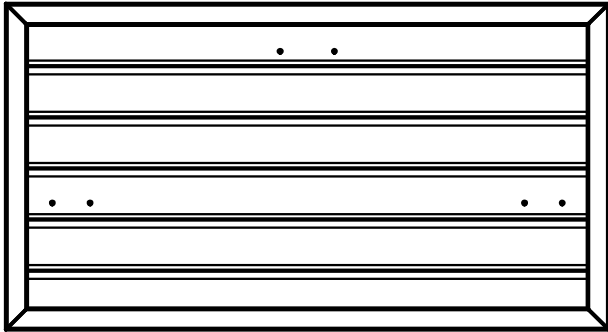

(1) WP1 - FRONT WALL PANEL - W2A02082
1"x20 3/8"x37 3/4" (24x517x958)

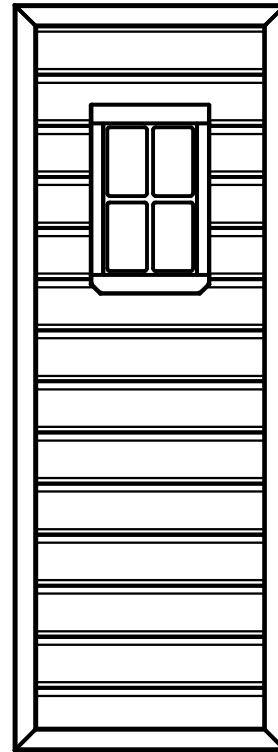

(2) WP2 - RIGHT LOWER WALL PANEL - W2A02083
1"x16 7/8"x46 1/2" (24x430x1181)

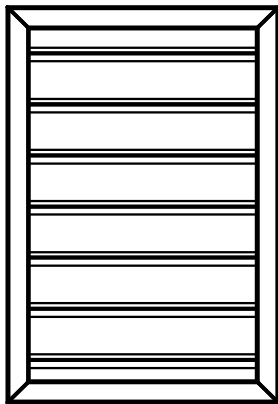

(2) WP3 - TOP RIGHT FRONT WALL PANEL - W2A02084
1"x16 7/8"x24 5/8" (24x430x627)

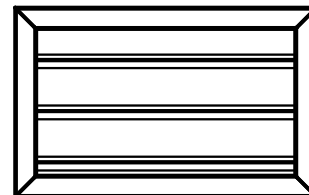

(1) WP6 - TOP REAR WALL PANEL - W2A02087
1"x18 7/8"x11 3/4" (24x479x300)

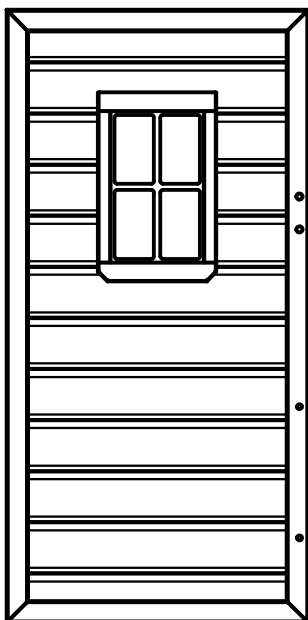

(1) WP5 - TOP LEFT REAR WALL PANEL - W2A02086
1"x16 7/8"x46 1/2" (24x430x971)

Parts Identification

Wood Components

(NOT TO SCALE)

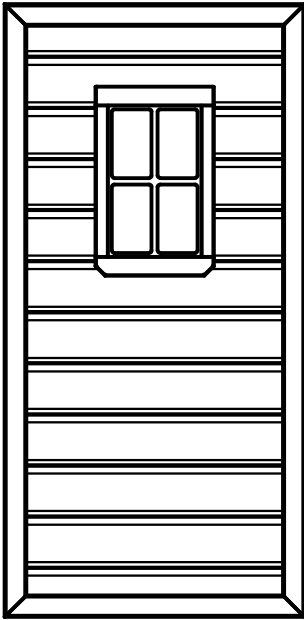

(1) WP7 - TOP FRONT WALL PANEL - W2A02088
1"x16 7/8"x38 1/4" (24x476x971)

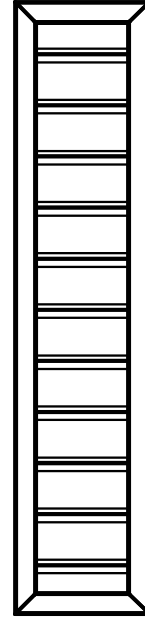

(2) WP8 - TOP LEFT WALL PANEL - W2A02089
1"x11 3/4"x38 1/4" (24x214x971)

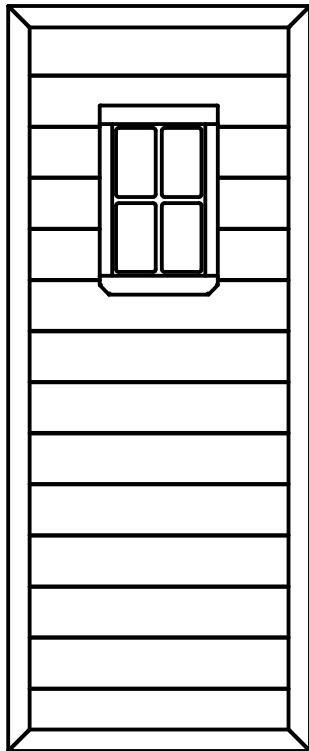

(2) WP9 - LOWER WALL PANEL - W2A02090
1"x16 7/8"x46 1/2" (24x476x1181)

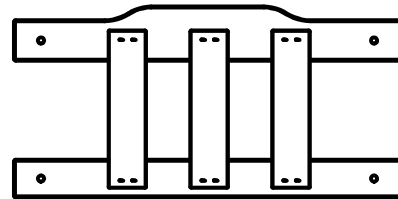

(2) WP10 - BENCH BACK ASSEMBLY - W2A02081
1 1/8"x11 7/8"x17 5/8" (27x303x615)

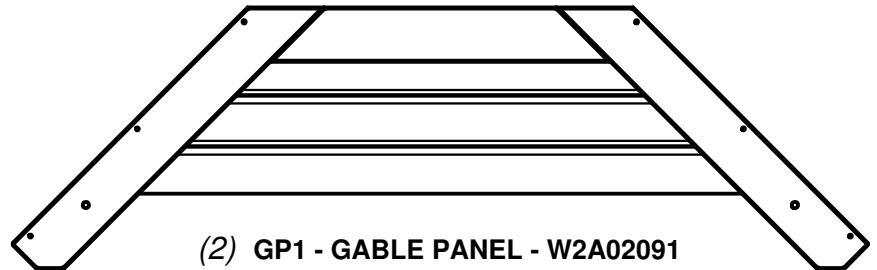

(2) GP1 - GABLE PANEL - W2A02091
1 1/8"x53 1/2"x16 3/8" (27x1359x414)

Parts Identification

Wood Components

(NOT TO SCALE)

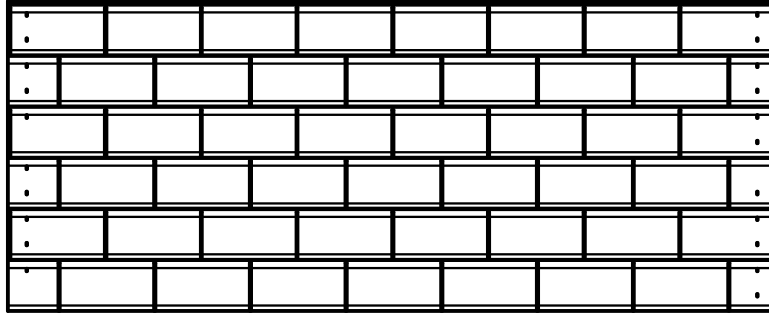

(2) RP1 - BOTTOM ROOF PANEL - W2A02092
1 3/8"x48"x19 3/8" (35x1220x491)

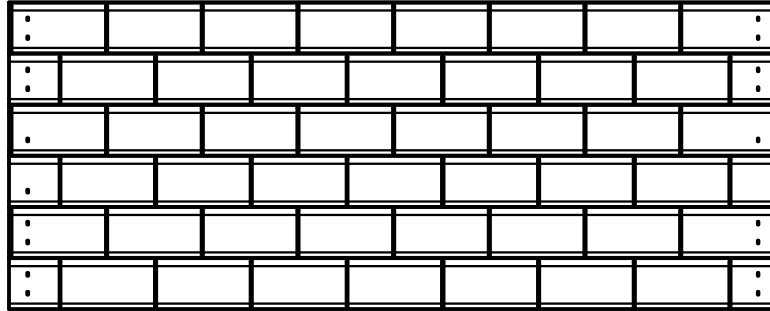

(2) RP2 - TOP ROOF PANEL - W2A02093
1 3/8"x48"x19 1/8" (35x1220x486)

Parts Identification

Hardware



(4) - SCREW PFH 8x1/2 - H100124

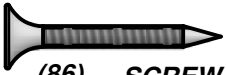

(86) - SCREW PFH 8x1-1/8" - H100088



(2) - SCREW PFH 8x1-1/4" - H100087



(245) - SCREW PFH 8x1-1/2" - H100086



(13) - SCREW PFH 8x1-3/4" - H100089



(41) - SCREW PFH 8x3 - H100092



(4) - SCREW PFH 8x1/2 BLK - H100203



(71) - SCREW PFH 8x1-1/4 BLK - H100387



(17) - SCREW PFH 8x1-1/2 BLK - H100200



(4) - SCREW PFH 8x1 3/4 BLK - H100382



(24) - SCREW PFH 8x2 BLK - H100391



(22) - SCREW PWH 8x5/8 - H100128



(1) - BOLT WH 5/16x4 1/2 BLK - H100534

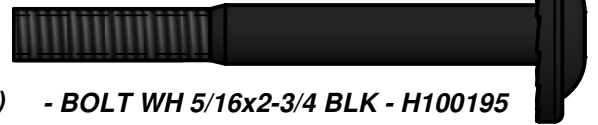

(3) - BOLT WH 5/16x2-3/4 BLK - H100195



(2) - BOLT WH 5/16x2-1/2 BLK - H100194



(7) - BOLT WH 5/16x2-1/4 BLK - H100205



(52) - BOLT WH 5/16x2 BLK - H100457



(10) - BOLT WH 5/16x1 3/4 BLK - H100378



(7) - BOLT WH 5/16x1 1/2 BLK - H100407



(9) - BOLT WH 5/16x1 1/4 BLK - H100459



(9) - BOLT WH 5/16x1/2 BLK - H100396



(28) - T-NUT 1/4 - H100072



(2) - T-NUT 1/4 BLK - H100398

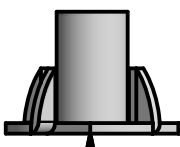

(7) - T-NUT 5/16 - H100074



(79) - T-NUT 5/16 BLK - H100379

Parts Identification

Hardware

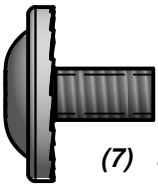

(7) - BOLT WH 5/16x1/2 - H100115

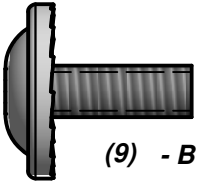

(9) - BOLT WH 5/16x3/4 - H100222

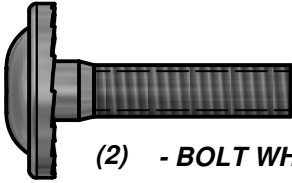

(2) - BOLT WH 5/16x1 1/4 - H100009

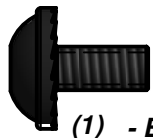

(1) - BOLT WH 1/4x1/2 BLK - H100401

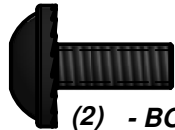

(2) - BOLT WH 1/4x5/8 BLK - H100486

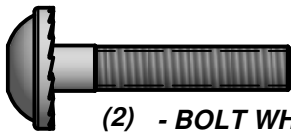

(2) - BOLT WH 1/4x1-1/4 - H100142

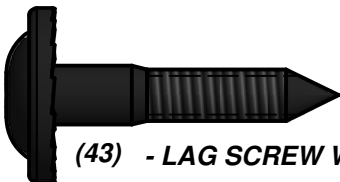

(43) - LAG SCREW WH 5/16x1-1/2 BLK - H100471



(9) - LAG SCREW WH 5/16x2 BLK - H100458



(2) - LAG SCREW WH 5/16x3 BLK - H100206

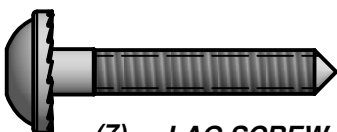

(7) - LAG SCREW WH 1/4x1-1/2 - H100145



(4) - LAG SCREW WH 1/4x1-1/2 BLK - H100403



(2) - LAG SCREW WH 1/4x2 BLK - H100487



(4) - BOLT HEX 5/16x1 - H100040



(2) - BOLT HEX 5/16x2-3/4 - H100047

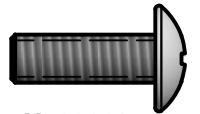

(26) - BOLT PTH 1/4x3/4 - H100063

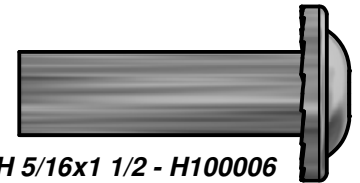

(9) - NUT BARREL WH 5/16x1 1/2 - H100006



(7) - NUT BARREL WH 5/16x5/8 BLK - H100469

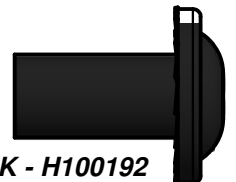

(13) - NUT BARREL WH 5/16x7/8 BLK - H100192

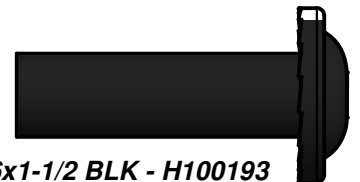

(2) - NUT BARREL WH 5/16x1-1/2 BLK - H100193



(1) - NUT BARREL WH 1/4x7/8 BLK - H100399

Parts Identification

Hardware



(9) - NUT LOCK 5/16 - H100110

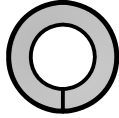

(4) - WASHER SPLIT 5/16 - H100095

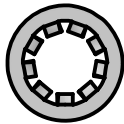

(26) - WASHER LOCK INT 8x15 - H100108

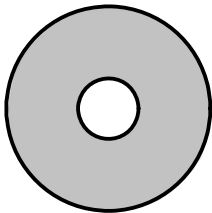

(16) - WASHER FLAT 8x27 - H100105

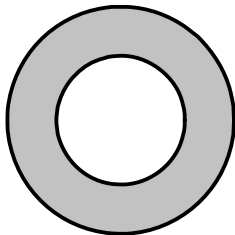

(7) - WASHER SAFETY 17x30 - H100103



(7) - WASHER LOCK EXT 6x15 BLK - H100405

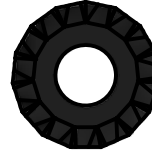

(133) - WASHER LOCK EXT 8x19 BLK - H100198

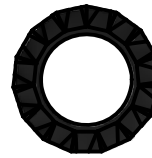

(16) - WASHER LOCK EXT 12x19 BLK - H100199

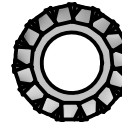

(9) - WASHER LOCK EXT 6x15 - H100138

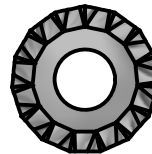

(9) - WASHER LOCK EXT 8x19 - H100030

Parts Identification

Hardware

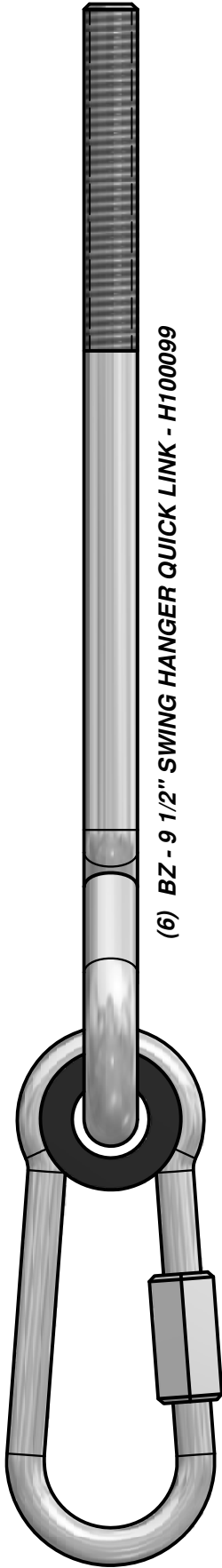

(2) - T-30 TORX WRENCH - H100114

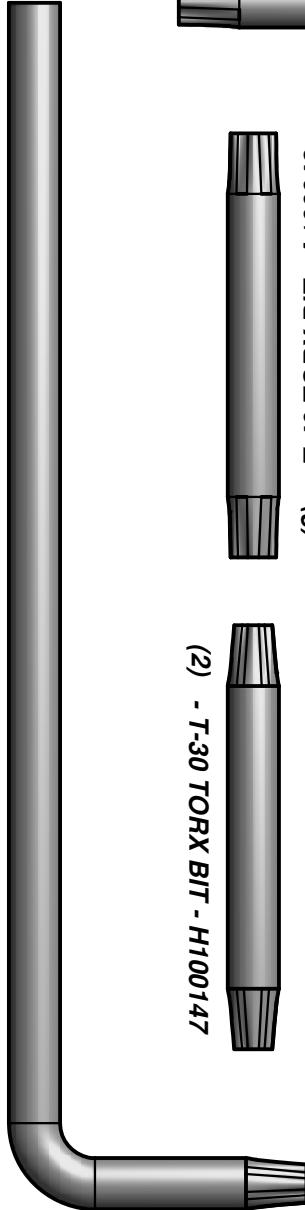

(2) - T-40 TORX WRENCH - A100041

Parts Identification

Accessories
(NOT TO SCALE)

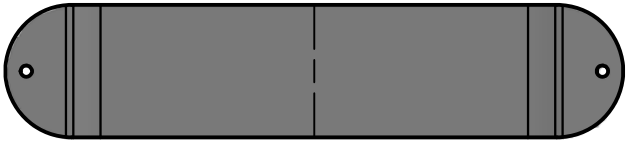

(2) DP - SWING SEAT GREEN - A100027

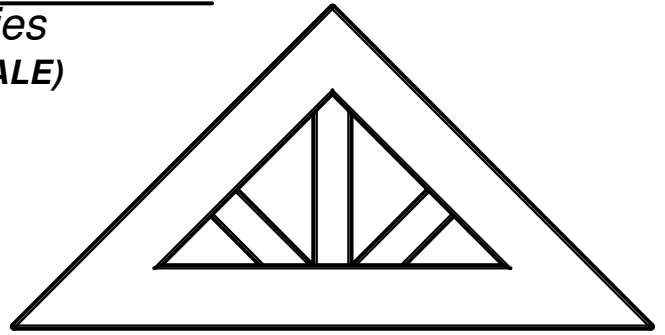

(2) SY - PLASTIC SUNBURST - A100322

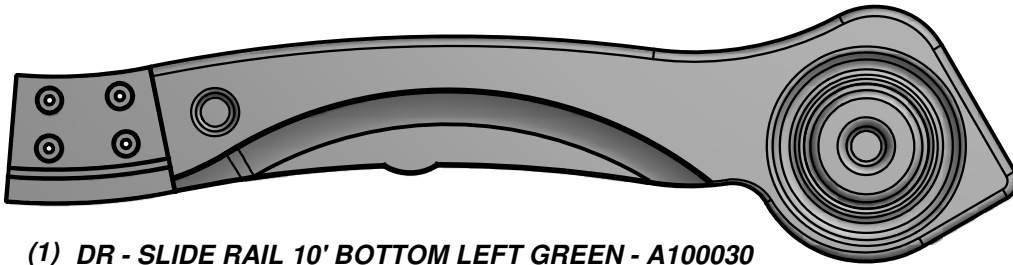

(1) DR - SLIDE RAIL 10' BOTTOM LEFT GREEN - A100030

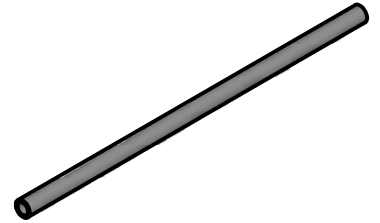

(4) DW - SLIDE SUPPORT TUBE 21.34x505 - A100034

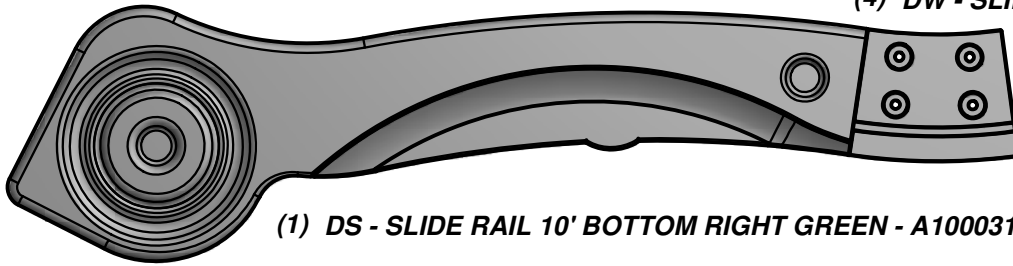

(1) DS - SLIDE RAIL 10' BOTTOM RIGHT GREEN - A100031

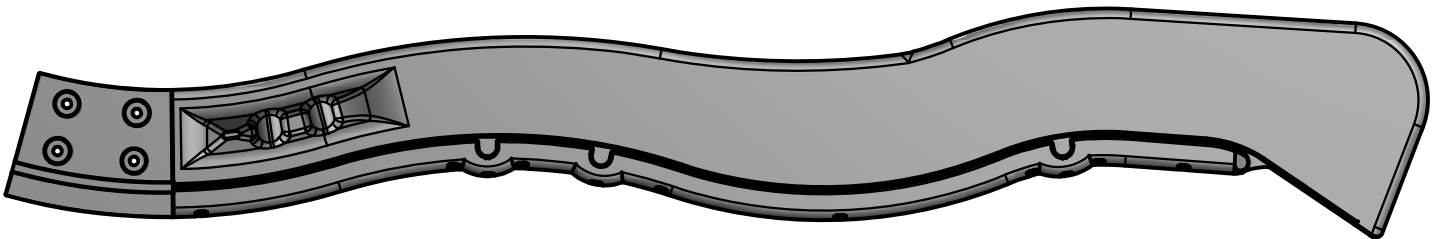

(1) DT - SLIDE RAIL 10' TOP LEFT GREEN - A100032

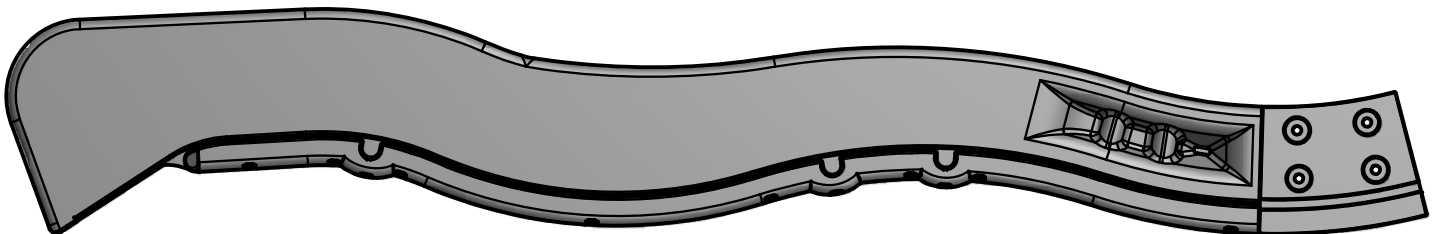

(1) TR - SLIDE RAIL 10' TOP RIGHT GREEN - A100033

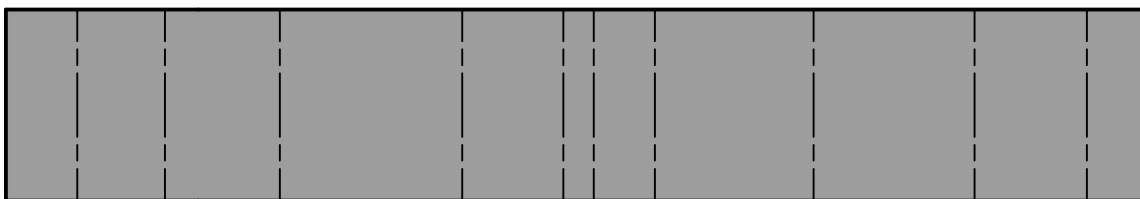

(1) DX - SLIDE BED 10' LIGHT GREEN - A100035

Parts Identification

Accessories
(NOT TO SCALE)

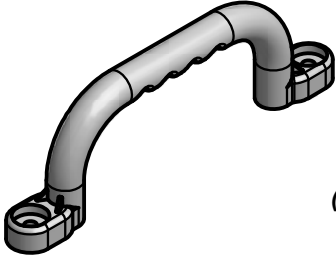

(4) EA - HAND GRIP YELLOW PLASTIC - A100043



(1) SQ - "A" REVISION TAG - A100314

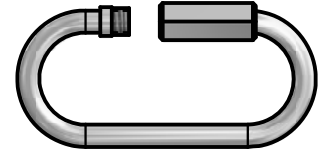

(6) FA - QUICK LINK - A100069

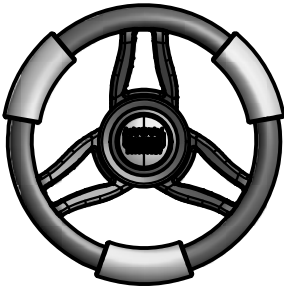

(1) LP - STEERING WHEEL - A100105

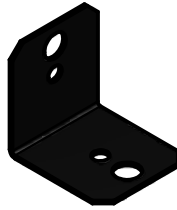

(2) - 90° L-BRACKET - BLK - A4M00555

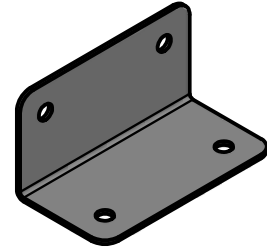

(2) GD - L BRACKET 66x66x127 - A100140

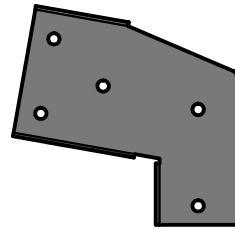

(1) TB - SWING BEAM EXTENSION BRACKET-LEFT - A100325

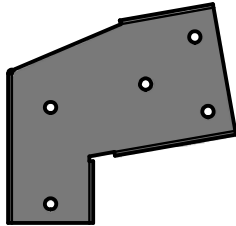

(1) TC - SWING BEAM EXTENSION BRACKET-RIGHT - A100326



(1) HC - BYD ID TAG (LARGE) WITHOUT AGES - A100242



(2) - L BRACKET BLACK 32x51 - A4M00710



(6) - GROUND STAKE REBAR - A4M00527



(2) KN - CHAIN GREEN 31" - A100177



(4) EZ - CHAIN GREEN 51.25" - A100068

Parts Identification

Accessories
(NOT TO SCALE)

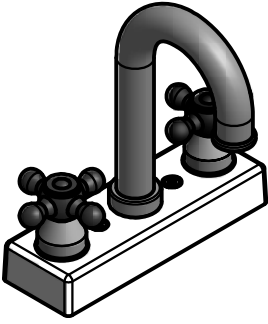

(1) - FAUCET KIT - A6P00024

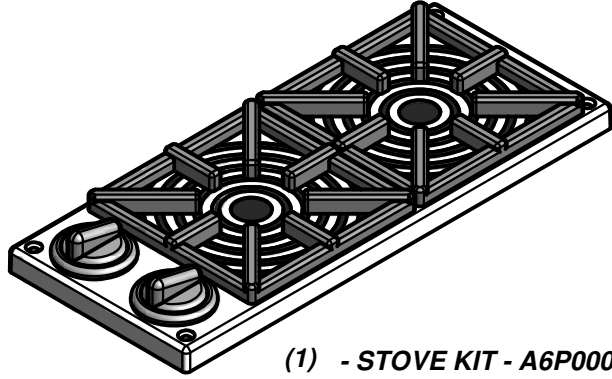

(1) - STOVE KIT - A6P00025

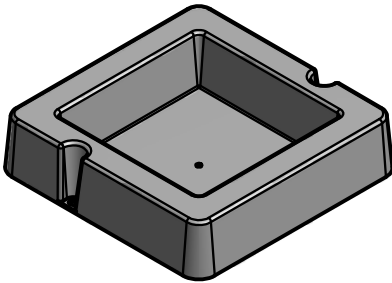

(1) - SURFACE MOUNT BASIN - A6P00032

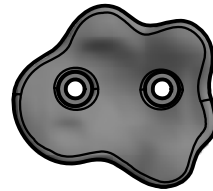

(3) - GREEN HC ROCK #1 - A6P00036

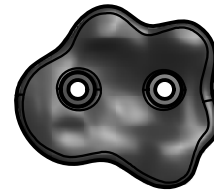

(3) - RED HC ROCK #1 - A6P00038



(1) - TRAPEZE - A6P00034

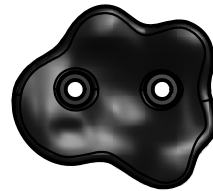

(3) - BLUE HC ROCK #2 - A6P00040

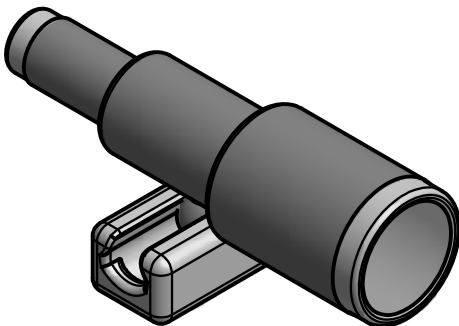

(1) LN - Telescope - A6P00096

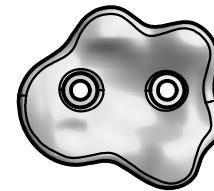

(3) - YELLOW HC ROCK #1 - A6P00042

Parts Identification

Accessories
(NOT TO SCALE)



APPLE

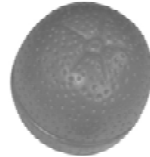

ORANGE



WATERMELON



STRAWBERRY

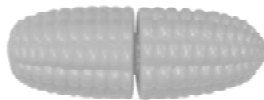

CORN

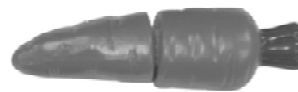

CARROT



PLASTIC KNIFE



CUTTING BOARD

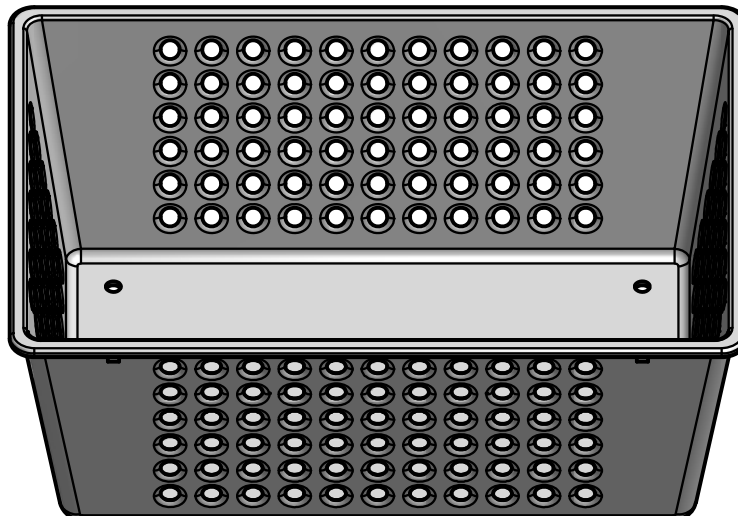

(1) FRUIT BASKET KIT - A6P00069



(1) H77 - LEFT UPRIGHT - W4L07617
1"x3 3/8"x58" (24x86x1474)



(4) H76 - LADDER RUNG - W4L07620
1"x3 3/8"x17 1/4" (24x86x437)

4 FT LADDER WITH ATTACHMENT BOARD

STEP 1

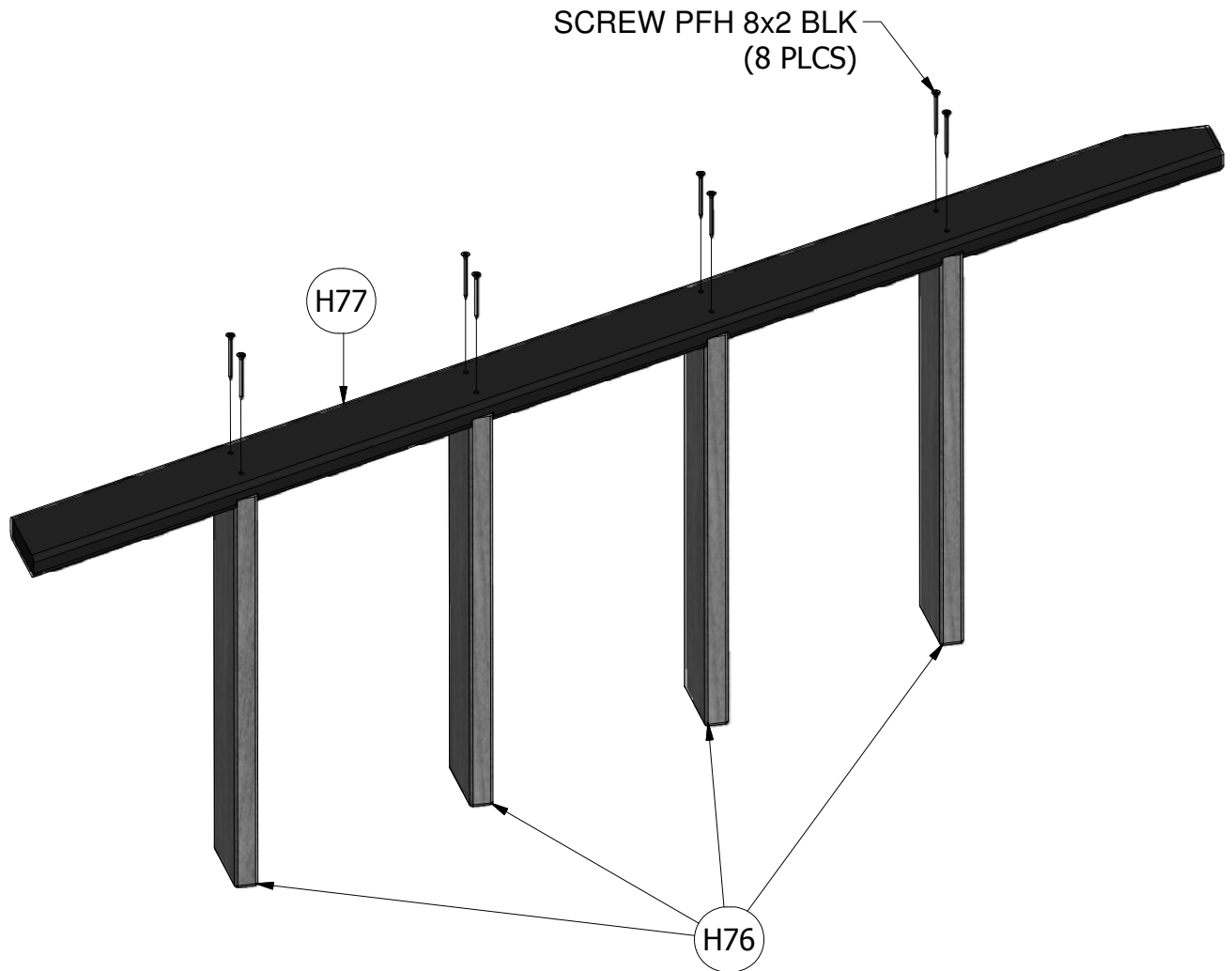
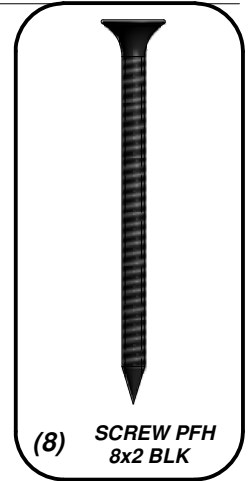



(1) H78 - RIGHT UPRIGHT - W4L07618
1"x3 3/8"x64 3/8" (24x86x1634)

STEP 2

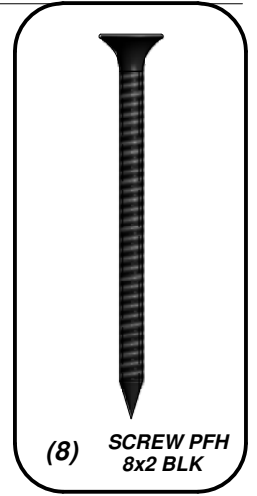

SCREW PFH 8x2 BLK
(8 PLCS)

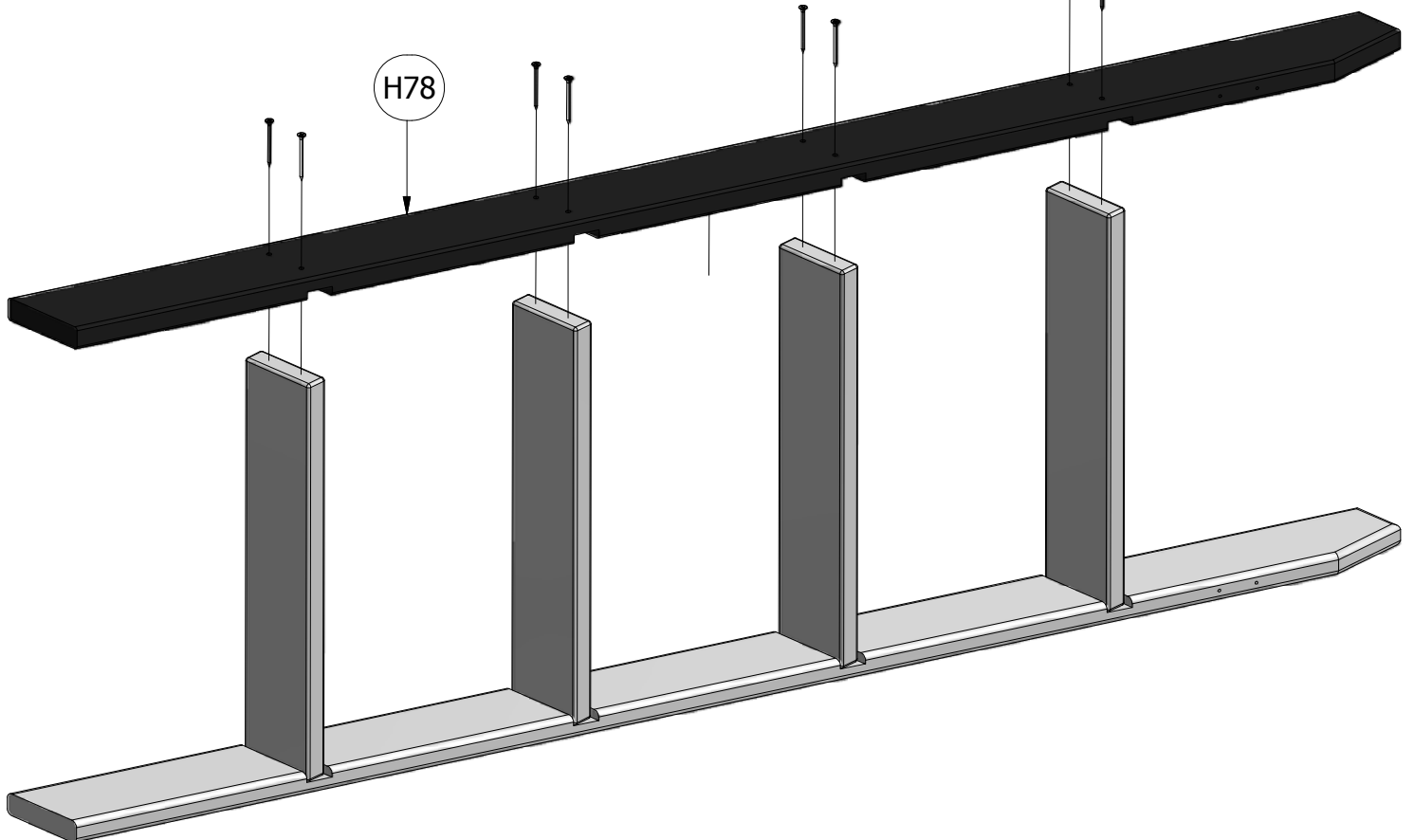



(1) **M110 - ATTACHMENT BOARD - W4L07621**
5/8"x3 3/8"x18 1/4" (16x86x465)



(1) **M73 - REAR SUPPORT - W4L07619**
5/8"x3 3/8"x18 1/4" (16x86x465)

STEP 3

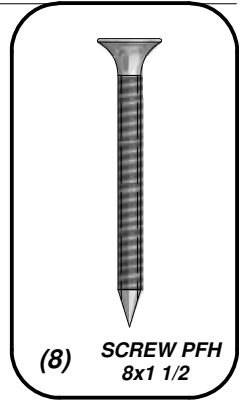

SCREW PFH 8x1 1/2
(8 PLCS)

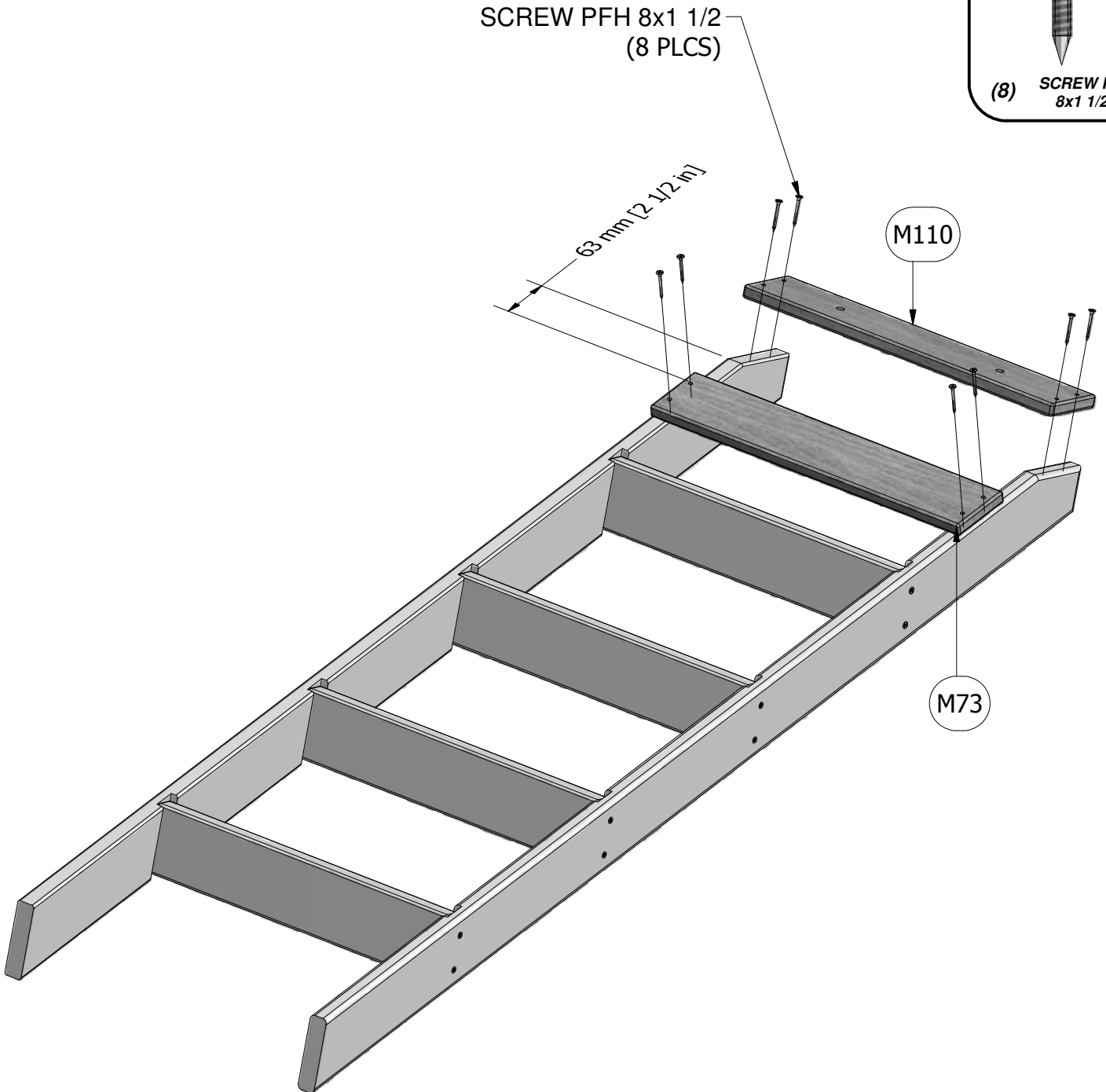

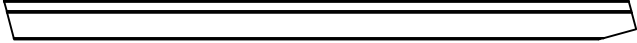

(1) **E72 - LEFT RAIL - W4L07622**
1 3/8"x3 3/8"x54 7/8" (36x86x1395)

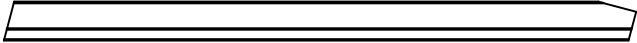

(1) **E73 - RIGHT RAIL - W4L07623**
1 3/8"x3 3/8"x54 7/8" (36x86x1395)



(1) **M108 - TOP BOARD - W4L07625**
5/8"x3 3/8"x26 1/4" (16x86x667)



(8) **M74 - ROCK WALL BOARD - W4L07624**
5/8"x3 3/8"x25" (16x86x635)



(4) **M75 - ROCK WALL BOARD - W4L07627**
5/8"x3 3/8"x25" (16x86x635)



(4) **M76 - ROCK WALL BOARD - W4L07626**
5/8"x3 3/8"x25" (16x86x635)

ROCKWALL STEP 1

SCREW PFH 8x1 1/2
(64 PLCS)

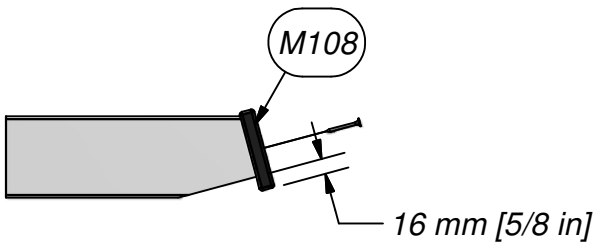
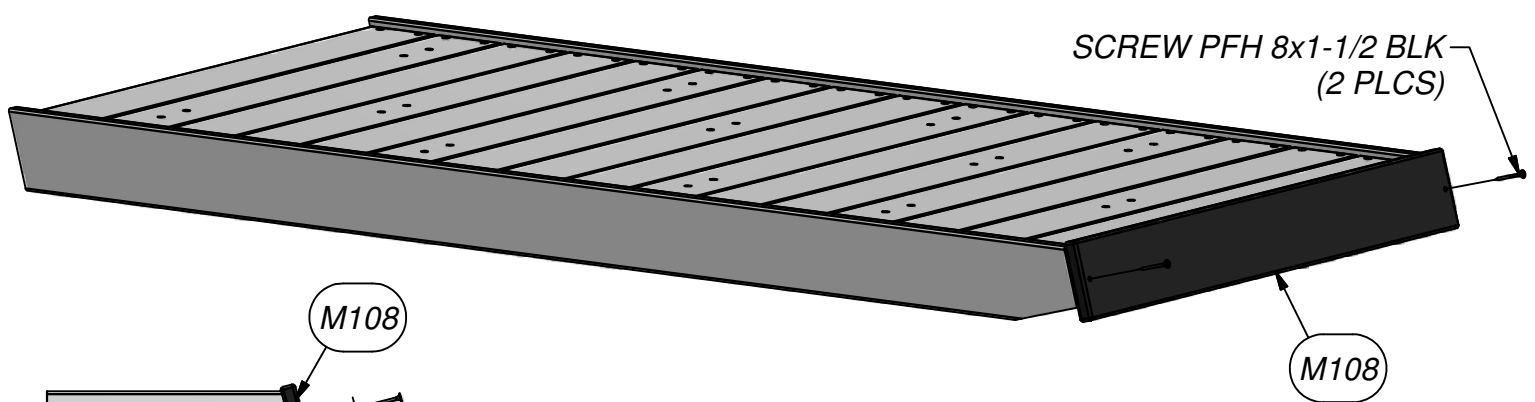
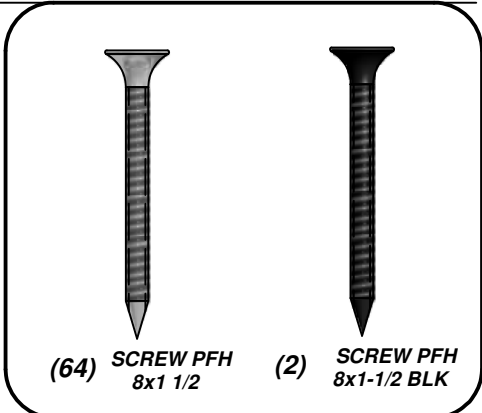
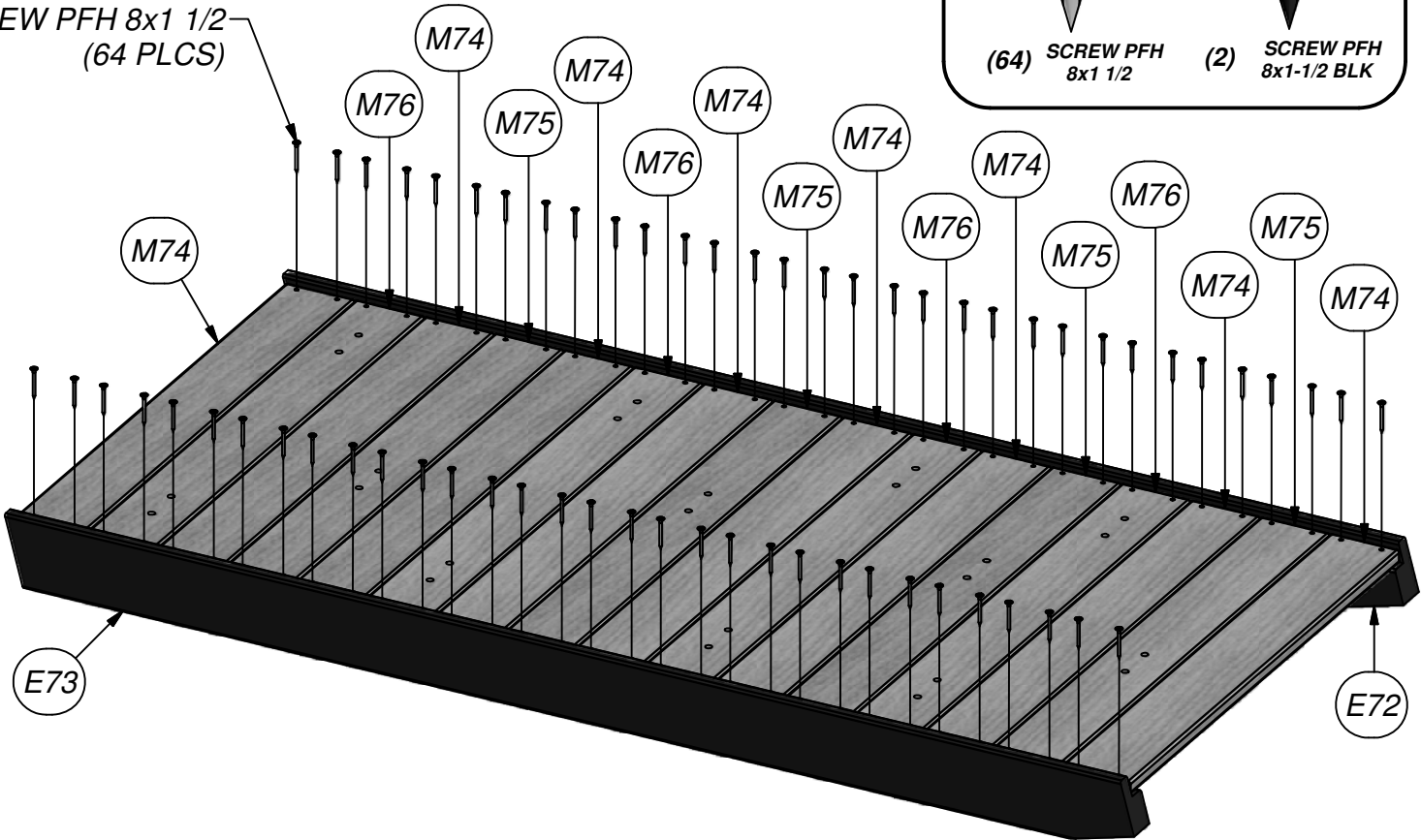



- (1) **M102 - ATTACHMENT BOARD - W4L07628**
5/8"x3 3/8"x26 1/4" (16x86x667)

**ROCKWALL
STEP 2**

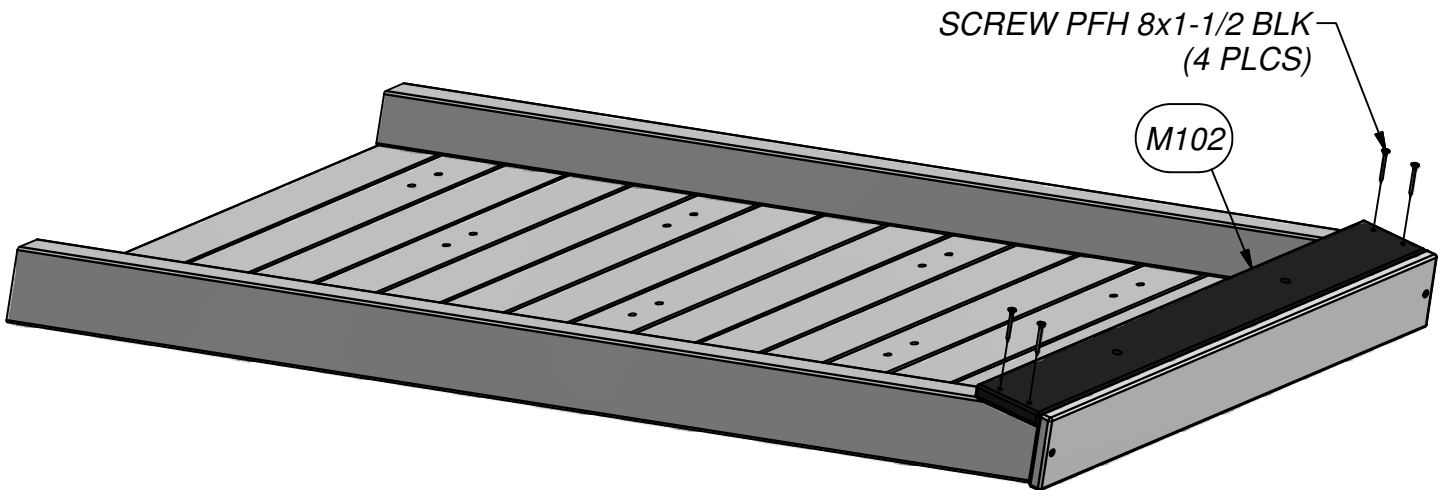
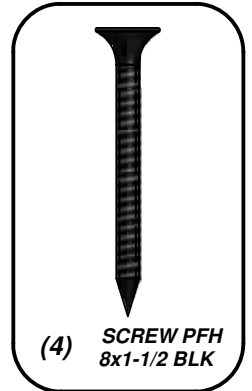



(3) - GREEN HC ROCK #1 - A6P00036



(3) - RED HC ROCK #1 - A6P00038



(3) - BLUE HC ROCK #2 - A6P00040

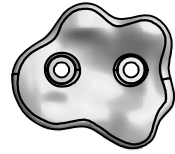

(3) - YELLOW HC ROCK #1 - A6P00042

ROCKWALL STEP 3

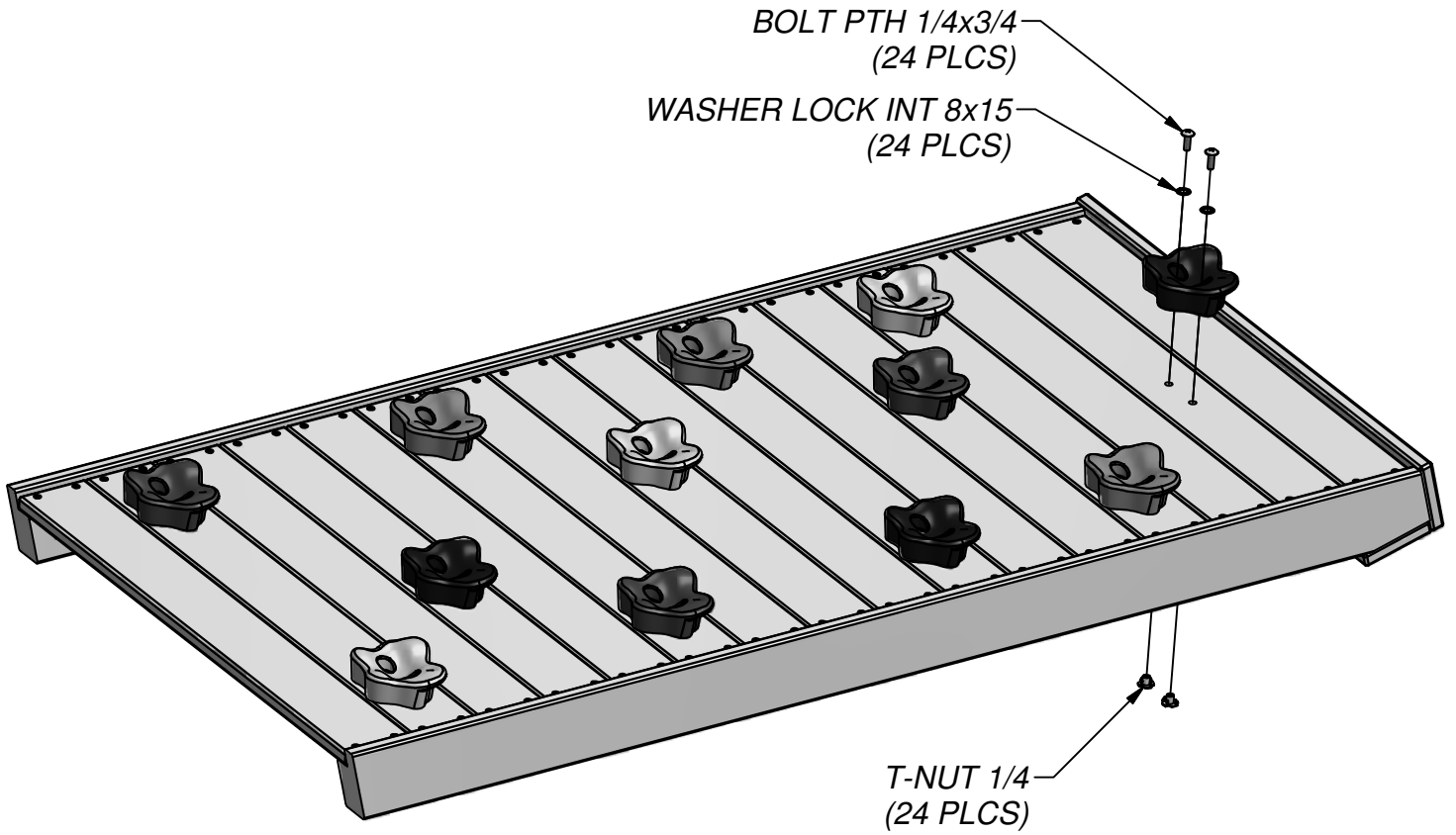
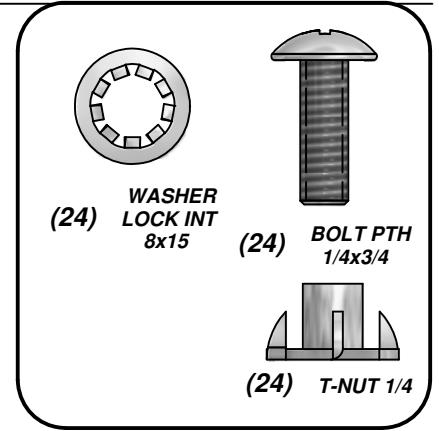

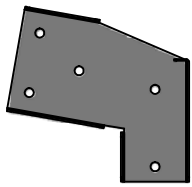

(1) **SB74 - SWING BEAM EXTENDED - W4L07633**
 2"x5 1/4"x89 1/2" (50x134x2274)

(1) **TC - SWING BEAM EXTENSION BRACKET-RIGHT - A100326**

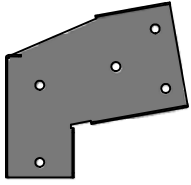

(1) **TB - SWING BEAM EXTENSION BRACKET-LEFT - A100325**

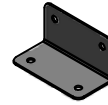

(2) **GD - L BRACKET 66x66x127 - A100140**

SWING BEAM ASSEMBLY
STEP 1

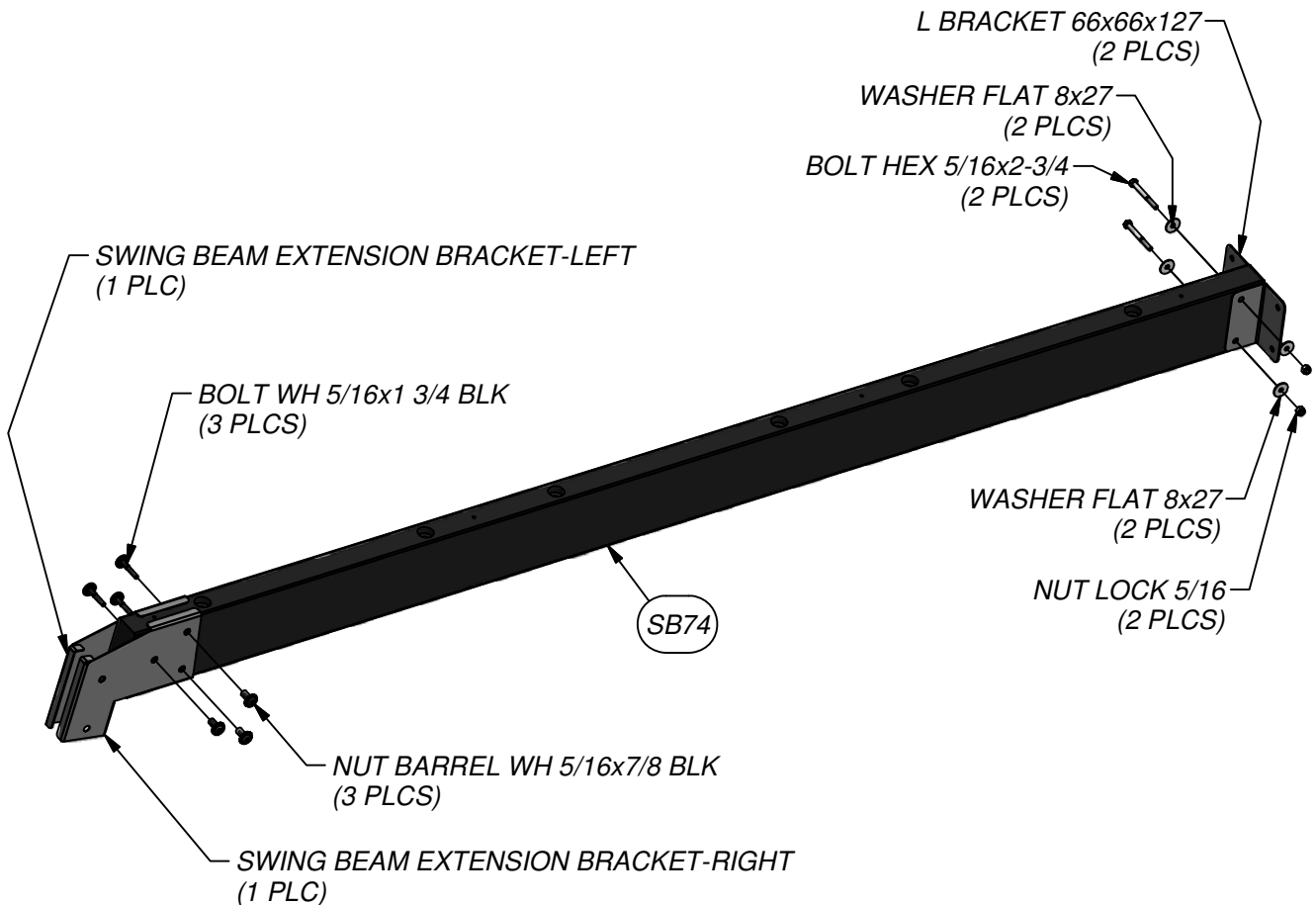
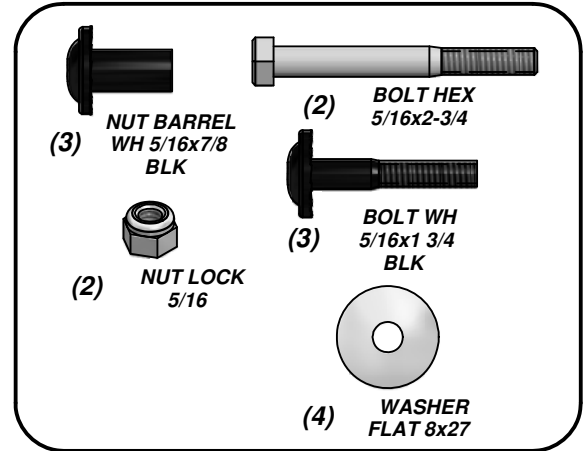



(1) H80 - GROUND BOARD - W4L07630
1"x3 3/8"x87 3/8" (24x86x2218)

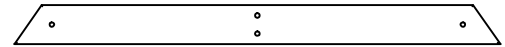

(1) H79 - END SUPPORT - W4L07632
1"x3 1/2"x42" (24x86x1072)

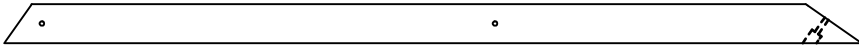

(2) E77 - ANGLE BRACE - W4L07631
1 3/8"x3 3/8"x74 3/8" (36x86x1890)

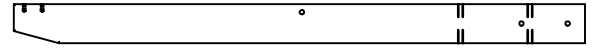

(1) W71 - SWING BEAM SUPPORT - W4L07629
2"x3 3/8"x49 5/8" (50x86x1260)

SWING BEAM ASSEMBLY STEP 2

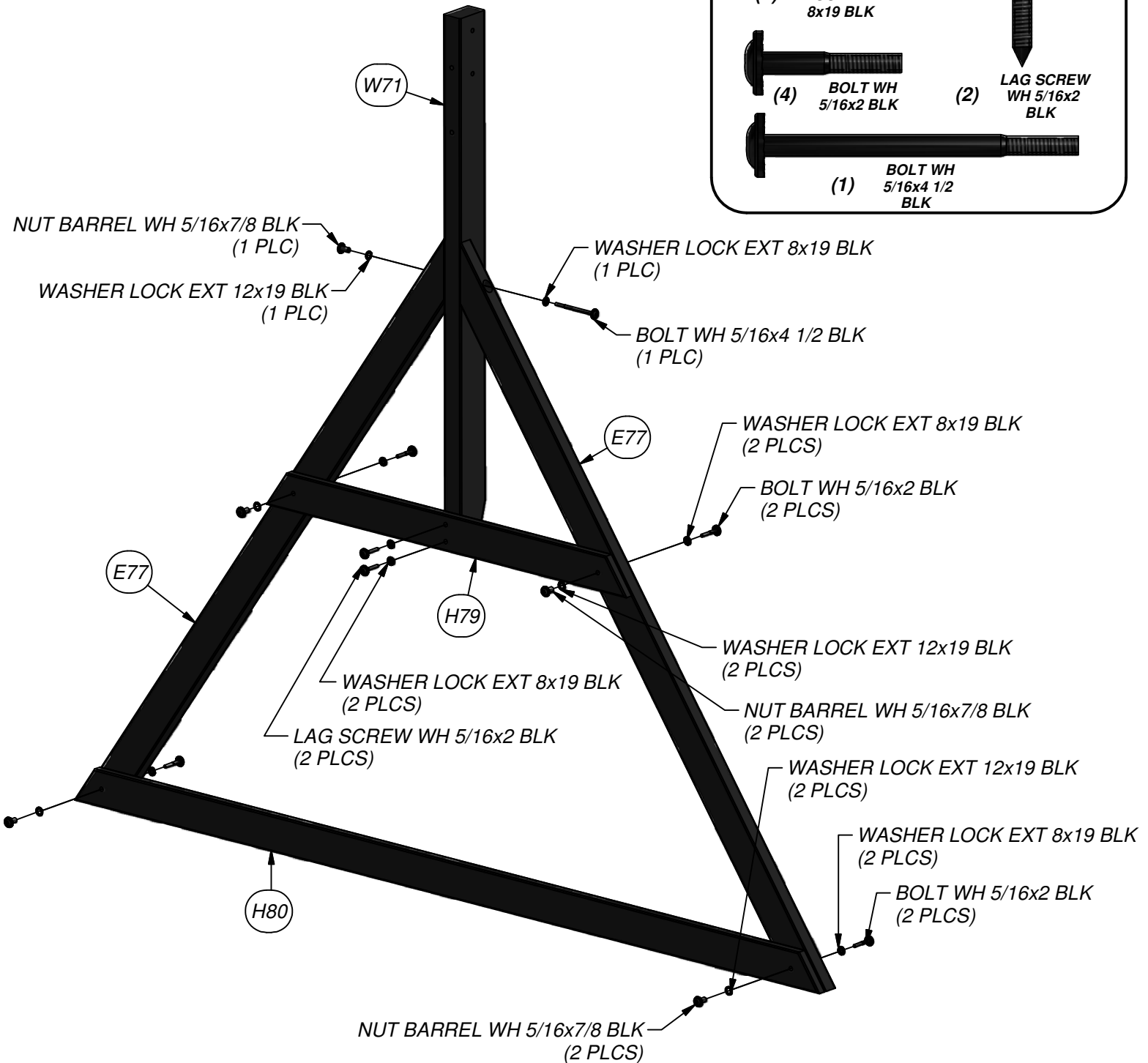
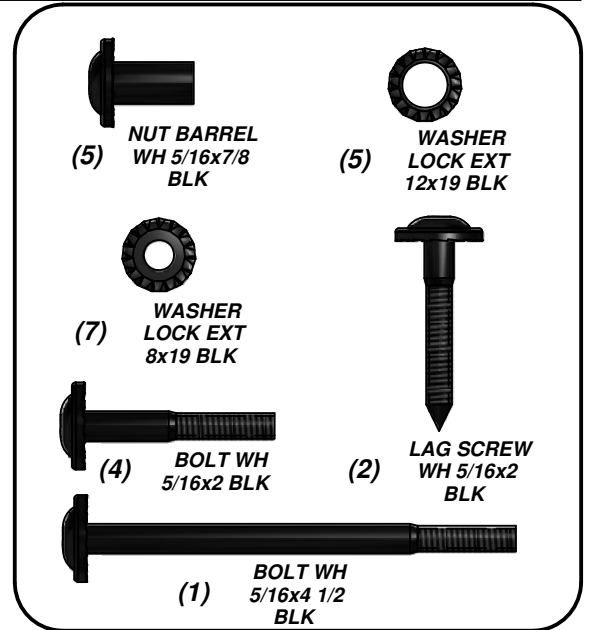

**SWING BEAM ASSEMBLY
STEP 3**

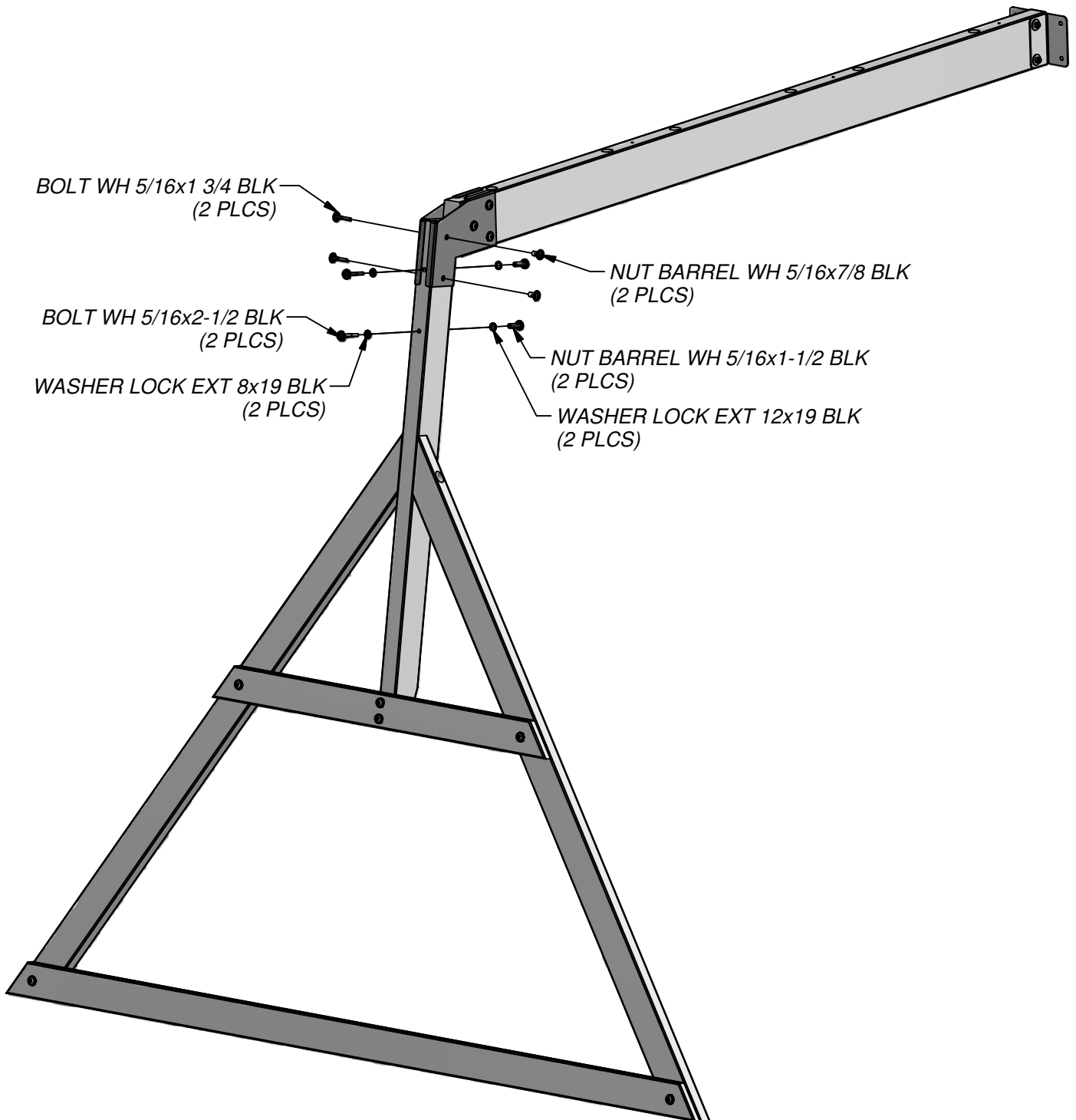
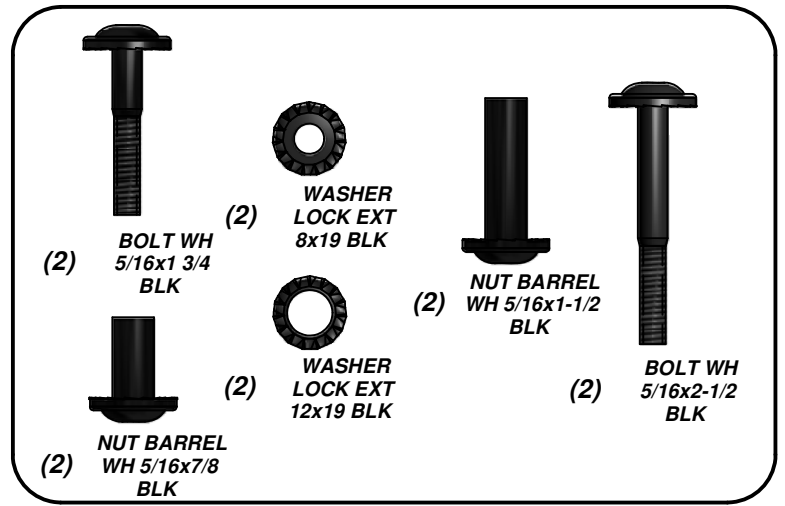

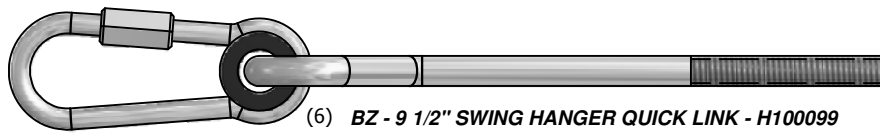

(6) BZ - 9 1/2" SWING HANGER QUICK LINK - H100099

**SWING BEAM ASSEMBLY
STEP 4**

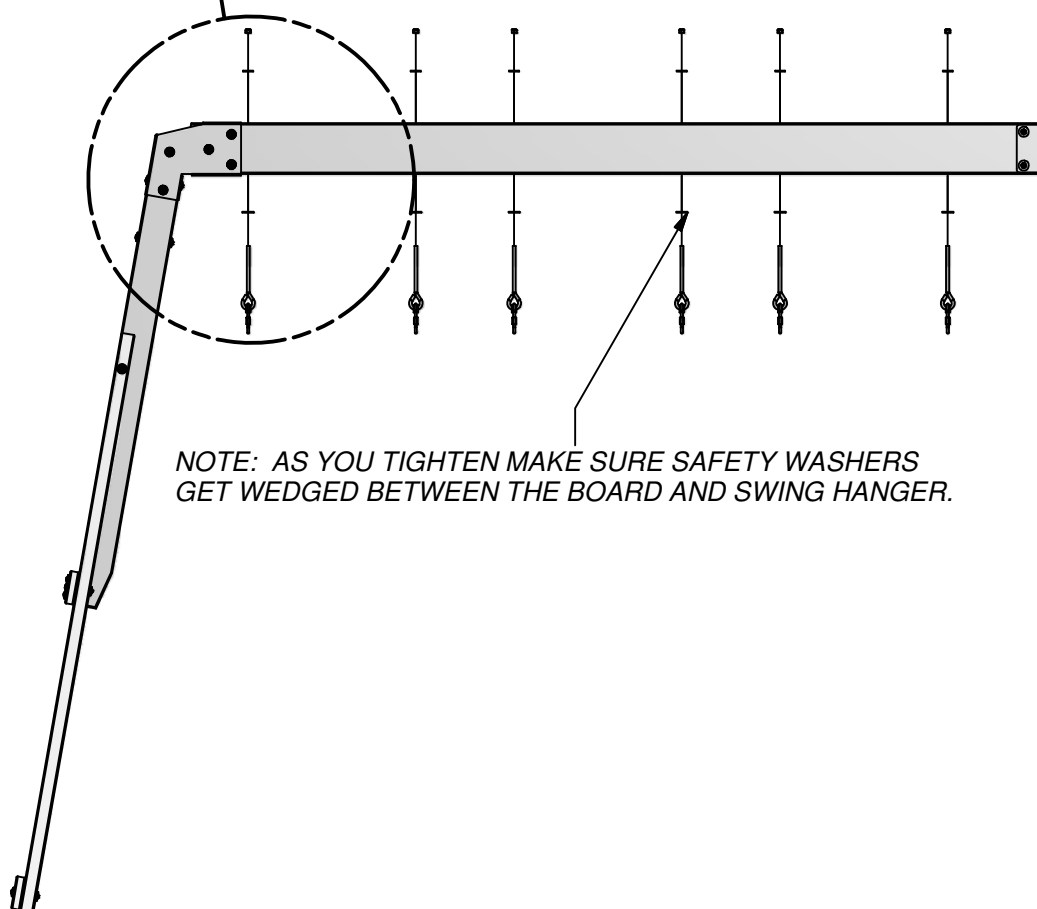
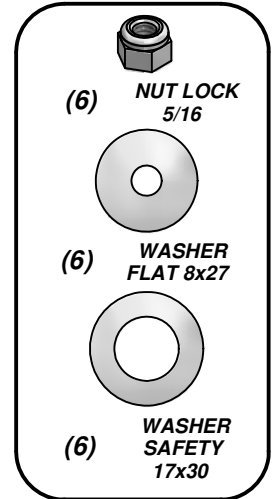
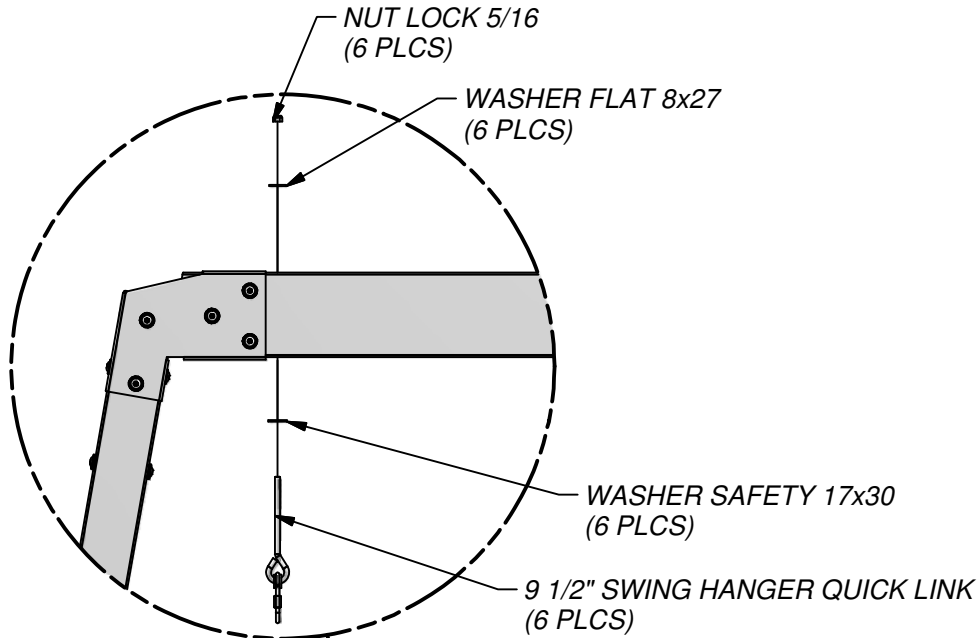

NOTE: AS YOU TIGHTEN MAKE SURE SAFETY WASHERS GET WEDGED BETWEEN THE BOARD AND SWING HANGER.



(1) DX - SLIDE BED 10' LIGHT GREEN - A100035



(1) M70 - SLIDE BED SUPPORT - W100935
5/8"x3 3/8"x19 7/8" (16x86x505)

STEP 1

10 FOOT SLIDE ASSEMBLY

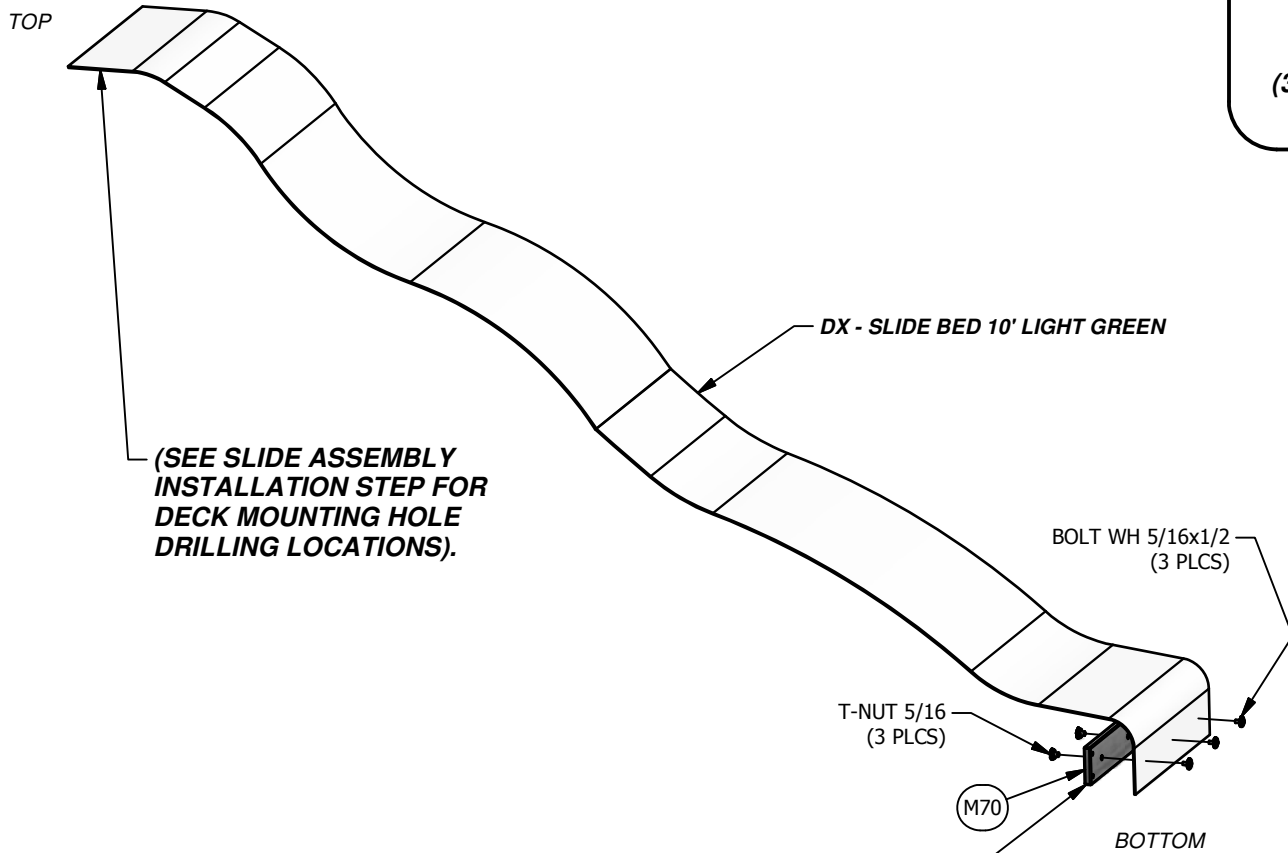
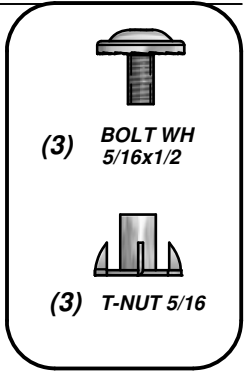

(SEE SLIDE ASSEMBLY
INSTALLATION STEP FOR
DECK MOUNTING HOLE
DRILLING LOCATIONS).

USE M70 SLIDE BED SUPPORT AS A
TEMPLATE FOR DRILLING BOTTOM
HOLE PATTERN IN SLIDE BED. BE SURE
TO PLACE SLIDE BRACE UP 1/2" FROM
BOTTOM EDGE OF SLIDE BED BEFORE
MARKING HOLE PATTERN. USE A 7/16"
DRILL BIT TO DRILL HOLE PATTERN.



TIP: PREBENDING THE ENDS WILL EASE ASSEMBLY.

(1) DS - SLIDE RAIL 10' BOTTOM RIGHT GREEN - A100031



(1) TR - SLIDE RAIL 10' TOP RIGHT GREEN - A100033



(1) DR - SLIDE RAIL 10' BOTTOM LEFT GREEN - A100030



(1) DT - SLIDE RAIL 10' TOP LEFT GREEN - A100032



10 FOOT SLIDE ASSEMBLY

STEP 2

- REPEAT ON OTHER SIDE, MAKING A LEFT AND RIGHT ASSEMBLY.

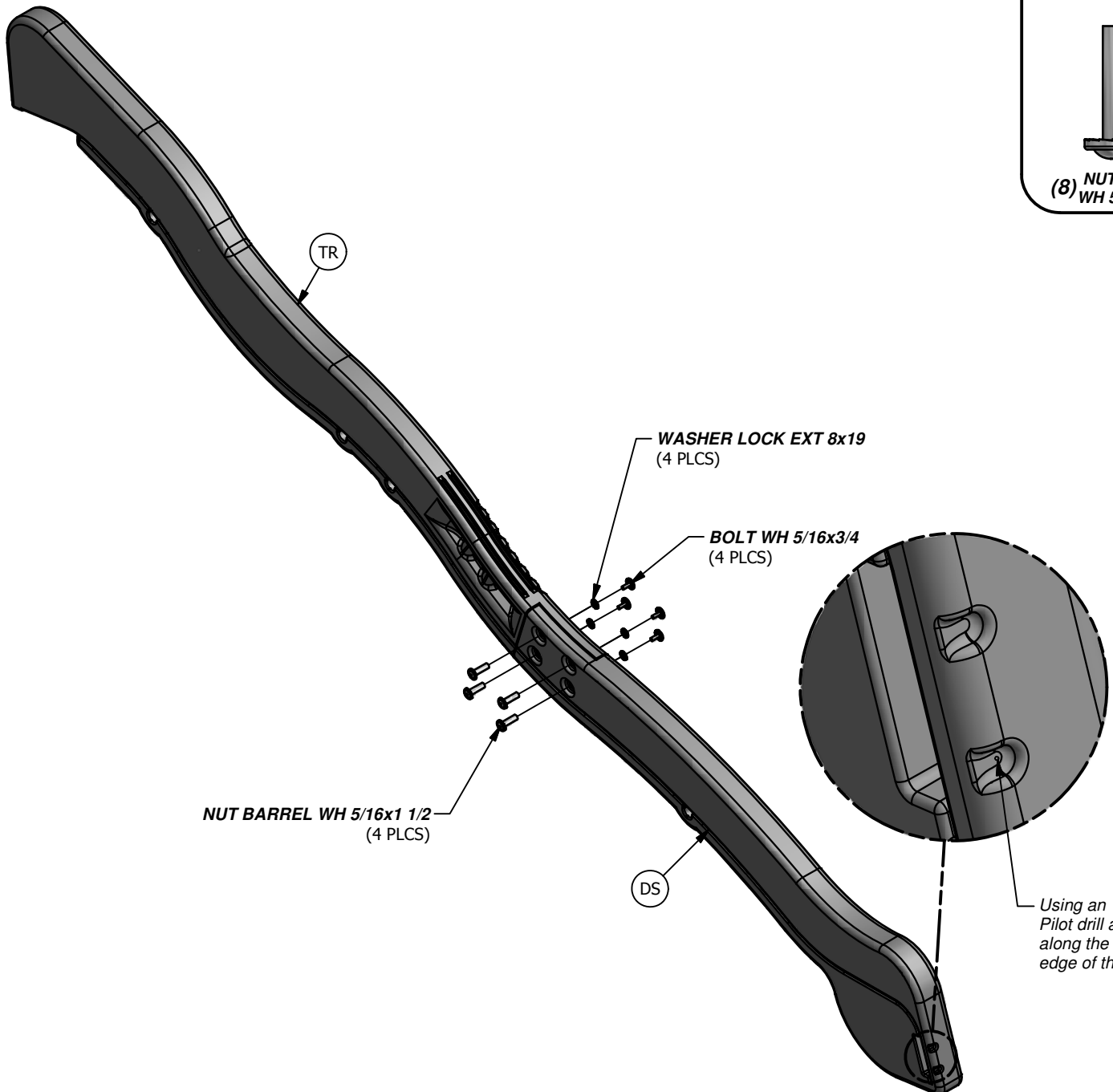
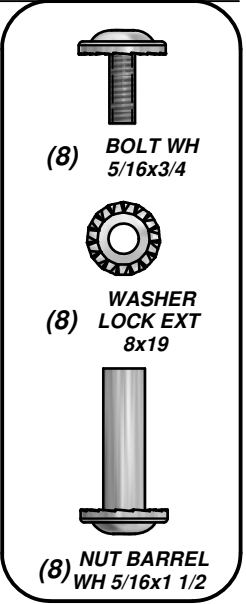

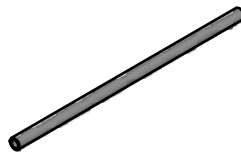

(4) DW - SLIDE SUPPORT TUBE 21.34x505 - A100034
21.34 OD x 2.77 W x 505

10 FOOT SLIDE ASSEMBLY

STEP 3

• PLACE (1) SLIDE RAIL ASSEMBLY ON A FLAT SURFACE AND BEGIN INSERTING SLIDE BED AT THE BOTTOM OF THE SLIDE RAIL (FIG. 1). HAVE A HELPER BEND THE SLIDE BED TOWARDS THE TOP OF THE SLIDE AND INSERT THE BED INTO THE SLIDE CAVITY. MAKE SURE SLIDE BED IS COMPLETELY DOWN IN THE SLIDE CAVITY.

• INSTALL THE (4) SLIDE SUPPORT TUBES INTO THEIR RESPECTIVE PILOT LOCATIONS (FIG. 2).

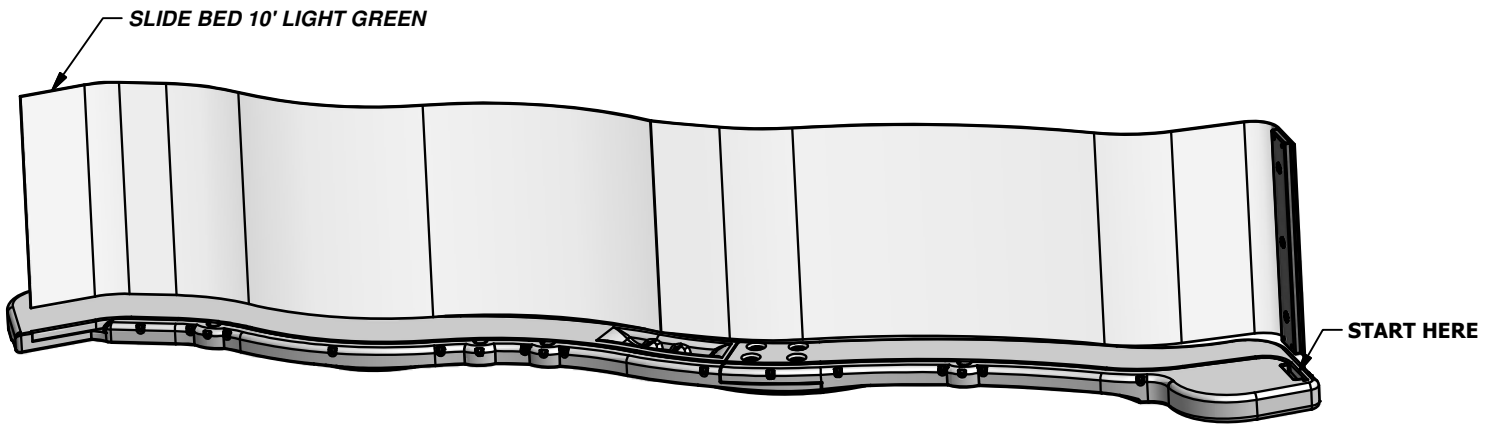

(FIG. 1)

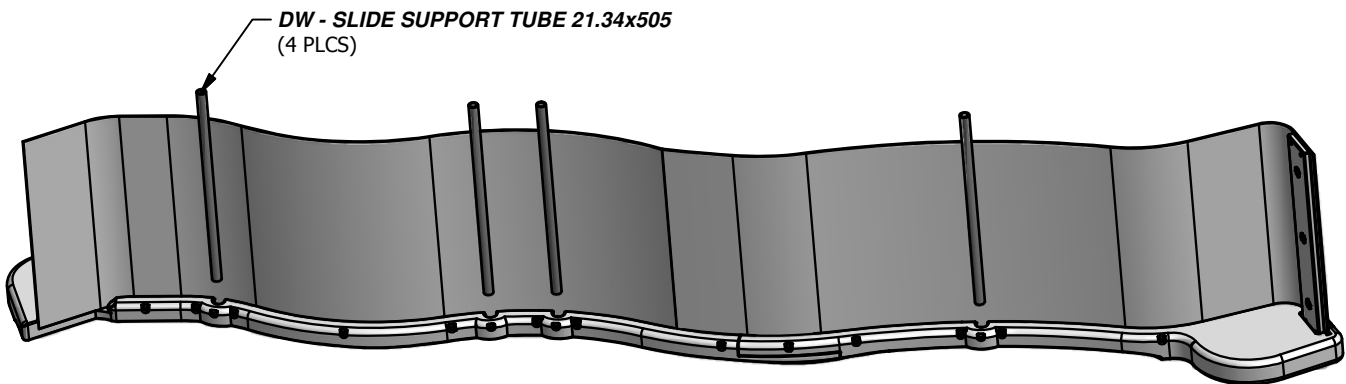

(FIG. 2)

10 FOOT SLIDE ASSEMBLY

STEP 4

- ONCE THE SLIDE BED, SUPPORT TUBES, AND SUPPORT BOARD ARE COMPLETELY IN THE CAVITY AND SUPPORT POCKET, SECURE USING 2-1/2" SCREWS AT EACH OF THE PILOT HOLE LOCATIONS AS SHOWN.
- REPEAT PROCESS FOR OPPOSITE SLIDE RAIL.

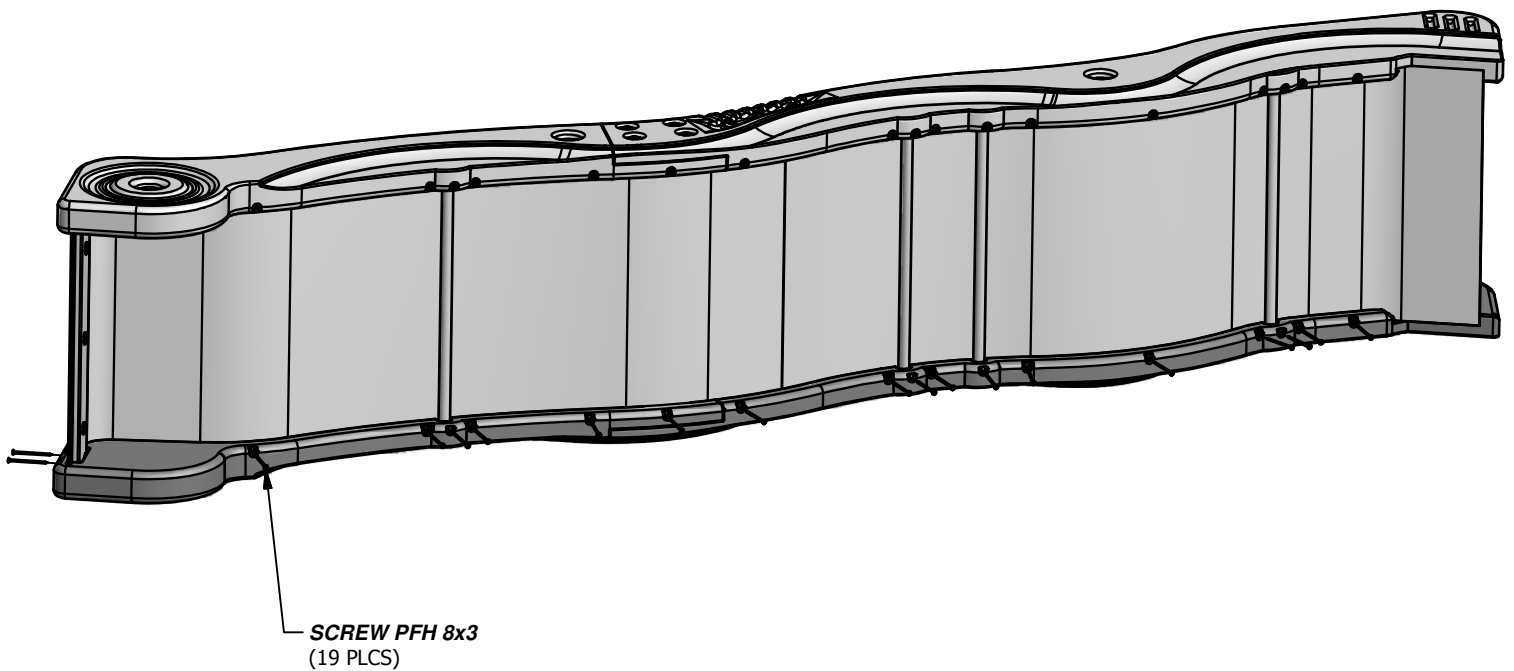
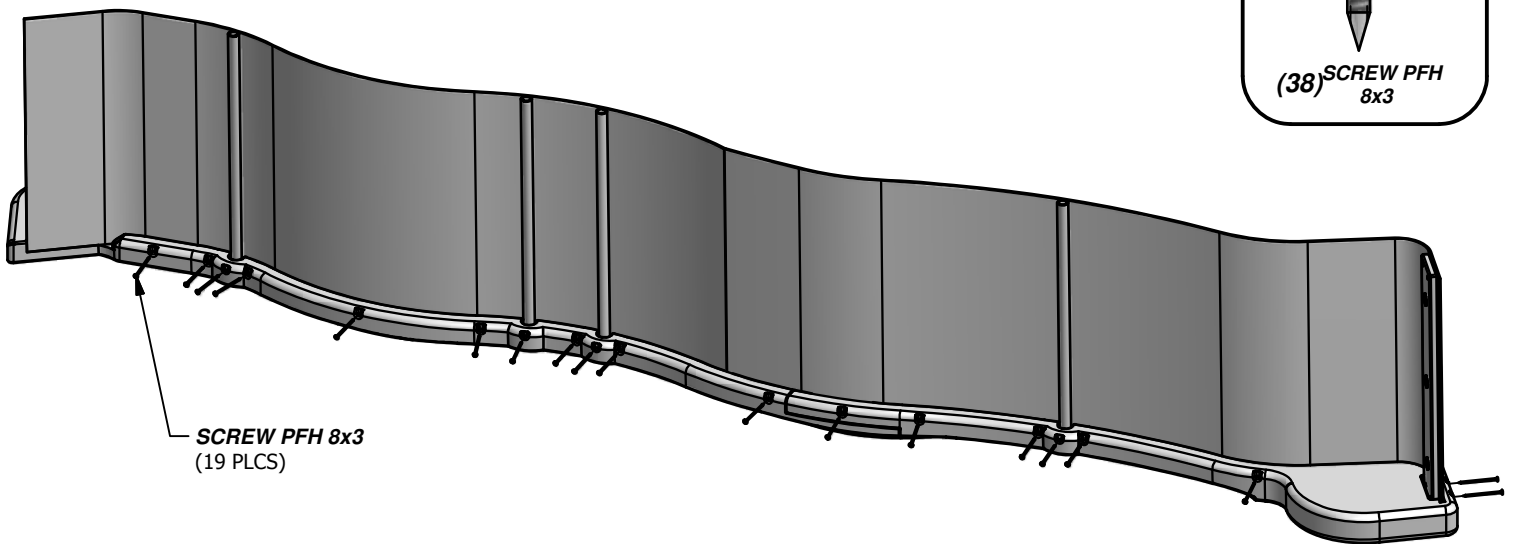
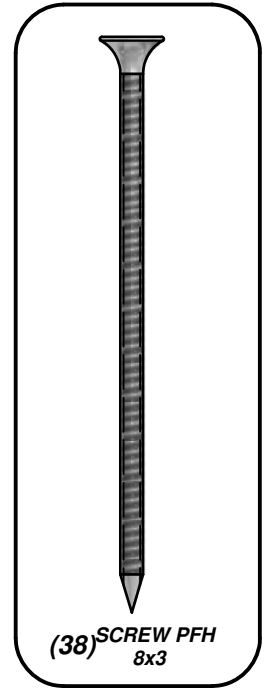

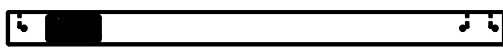

(1) E1 - RIGHT REAR UPRIGHT - W2A02080
1 3/8"x3 3/8"x51 3/4" (36x86x1314)

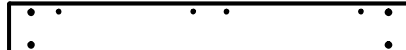

(1) K1 - GROUND BOARD - W4L07489
5/8"x5 1/4"x41 7/8" (16x134x1064)



(1) G1 - SWING BEAM MOUNT - W4L07513
1"x5 1/4"x62 1/8" (24x134x1577)

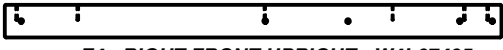

(1) E4 - RIGHT FRONT UPRIGHT - W4L07495
1 3/8"x3 3/8"x51 3/4" (36x86x1314)

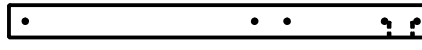

(1) E9 - RIGHT FRONT UPRIGHT - W4L07512
1 3/8"x3 3/8"x43 1/2" (36x86x1104)



(1) K5 - RIGHT CENTER WALL RAIL - W4L07496
5/8"x5 1/4"x62 3/4" (16x134x1593)



(1) E7 - RIGHT REAR UPRIGHT - W4L07510
1 3/8"x3 3/8"x43 1/2" (36x86x1104)



(1) K12 - ARCHED WALL RAIL - W4L07579
5/8"x5 1/4"x40 5/8" (16x134x1032)



(1) SQ - "A" REVISION TAG - A100314

STEP 1

INSTALL T-NUTS INTO PARTS BEFORE ASSEMBLY OF PARTS.

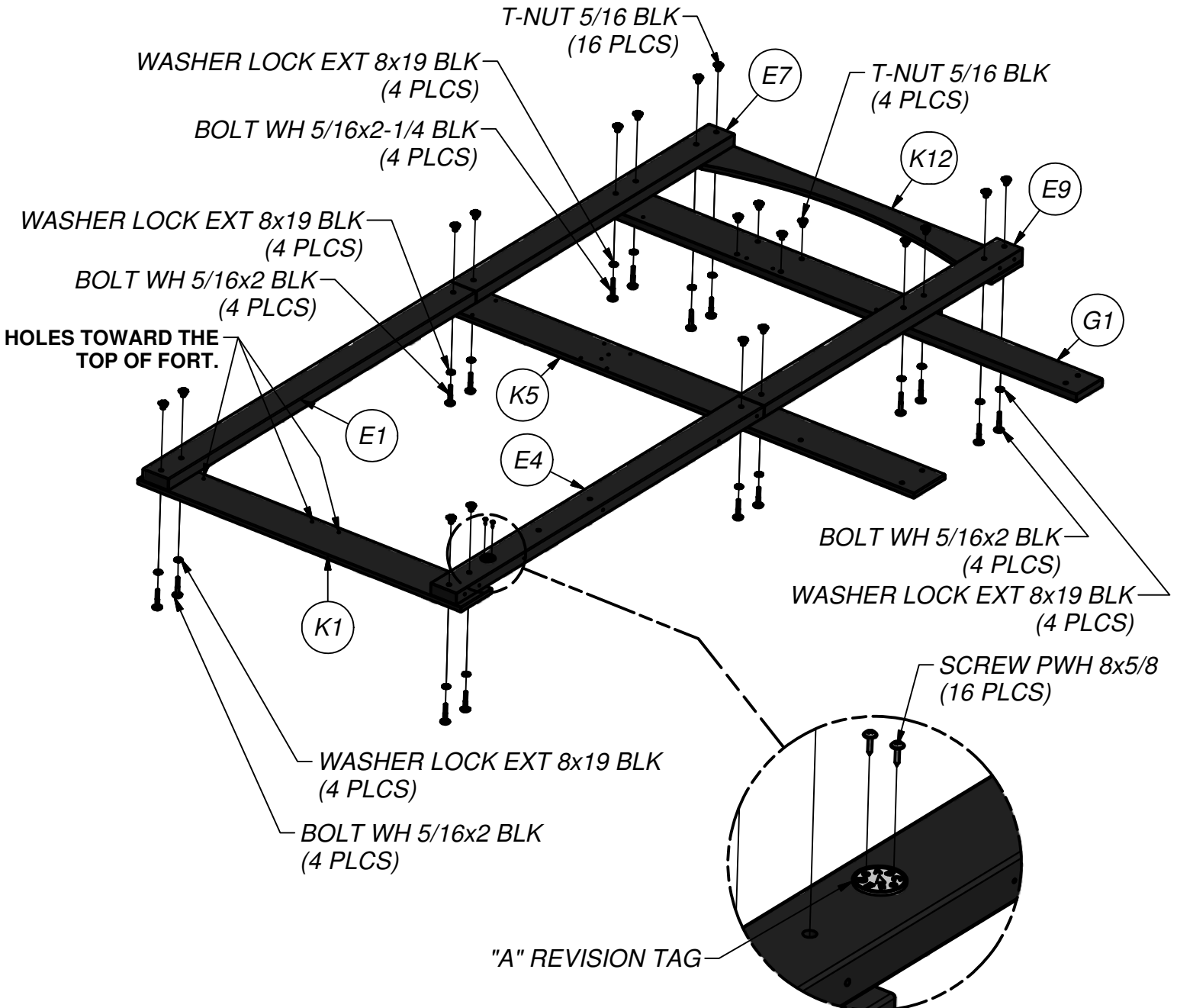
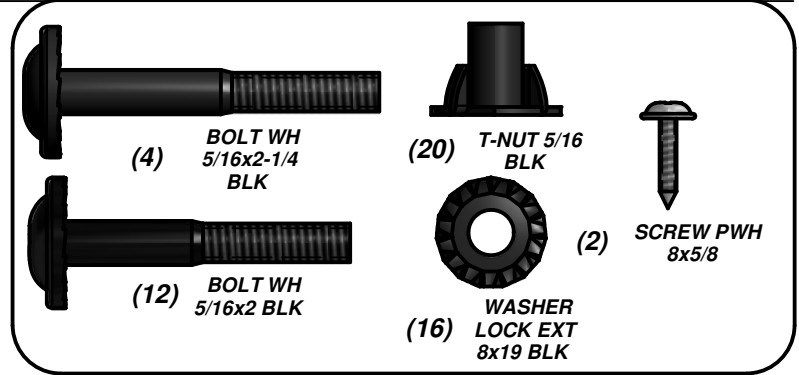

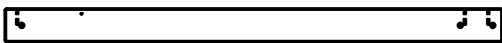

(1) **E2 - LEFT REAR UPRIGHT - W4L07493**
1 3/8"x3 3/8"x51 3/4" (36x86x1314)

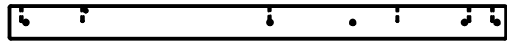

(1) **E3 - LEFT FRONT UPRIGHT - W4L07494**
1 3/8"x3 3/8"x51 3/4" (36x86x1314)



(1) **E6 - LEFT REAR UPRIGHT - W4L07509**
1 3/8"x3 3/8"x43 1/2" (36x86x1104)



(1) **E8 - LEFT FRONT UPRIGHT - W4L07511**
1 3/8"x3 3/8"x43 1/2" (36x86x1104)



(1) **K2 - GROUND BOARD - W4L07490**
5/8"x5 1/4"x41 7/8" (16x134x1064)



(1) **K8 - LEFT CENTER WALL RAIL - W4L07499**
5/8"x5 1/4"x40 5/8" (16x134x1032)



(1) **K13 - ARCHED WALL RAIL - W4L07580**
5/8"x5 1/4"x40 5/8" (16x134x1032)

STEP 2

INSTALL T-NUTS INTO PARTS BEFORE ASSEMBLY OF PARTS.

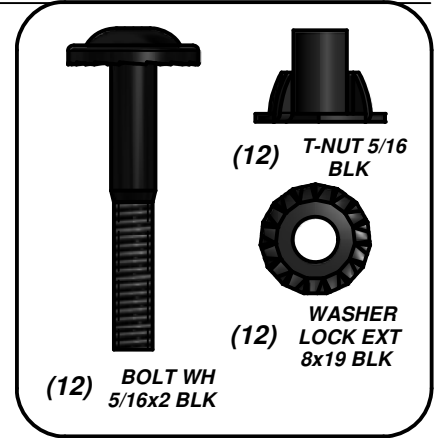

(12) **T-NUT 5/16 BLK**

(12) **WASHER LOCK EXT 8x19 BLK**

(12) **BOLT WH 5/16x2 BLK**

T-NUT 5/16 BLK (12 PLCS)

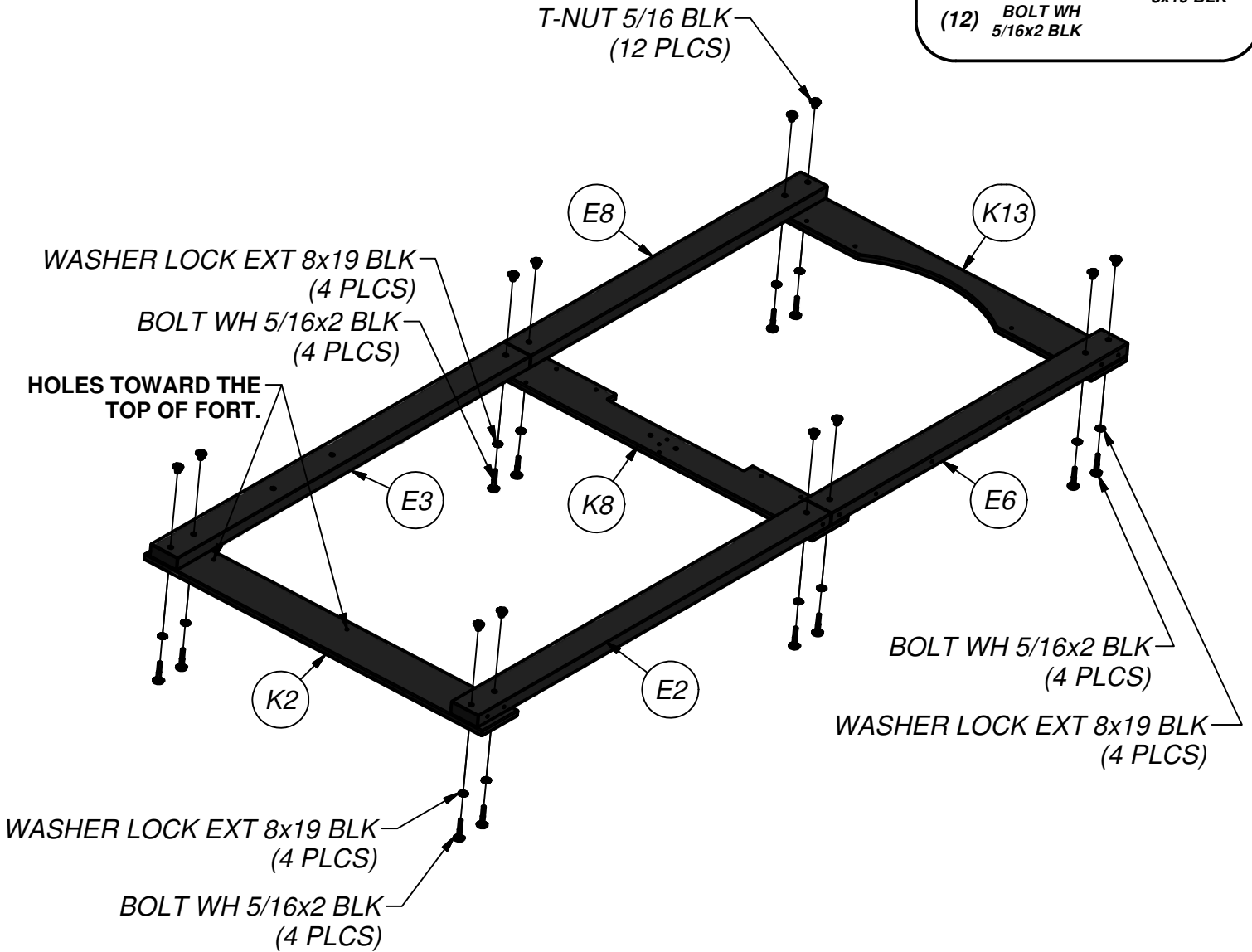

(1) **J1 - PORCH GROUND BOARD - W4L07504**
1"x2 3/8"x40 1/2" (24x60x1030)

(1) **K4 - GROUND BOARD - W4L07492**
5/8"x5 1/4"x40 1/2" (16x134x1030)

(1) **M1 - WALL RAIL - W4L07590**
5/8"x3 3/8"x40 1/2" (16x86x1030)

(1) **K6 - FRONT CENTER WALL RAIL - W4L07497**
5/8"x5 1/4"x61 3/8" (16x134x1560)

(1) **K15 - ANGLED WALL RAIL - W4L07582**
5/8"x5 1/4"x45 3/4" (16x134x1162)

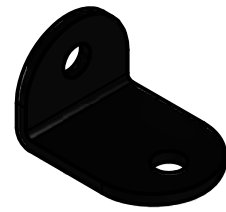

(1) - **L BRACKET BLACK 32x51 - A4M00710**

STEP 3

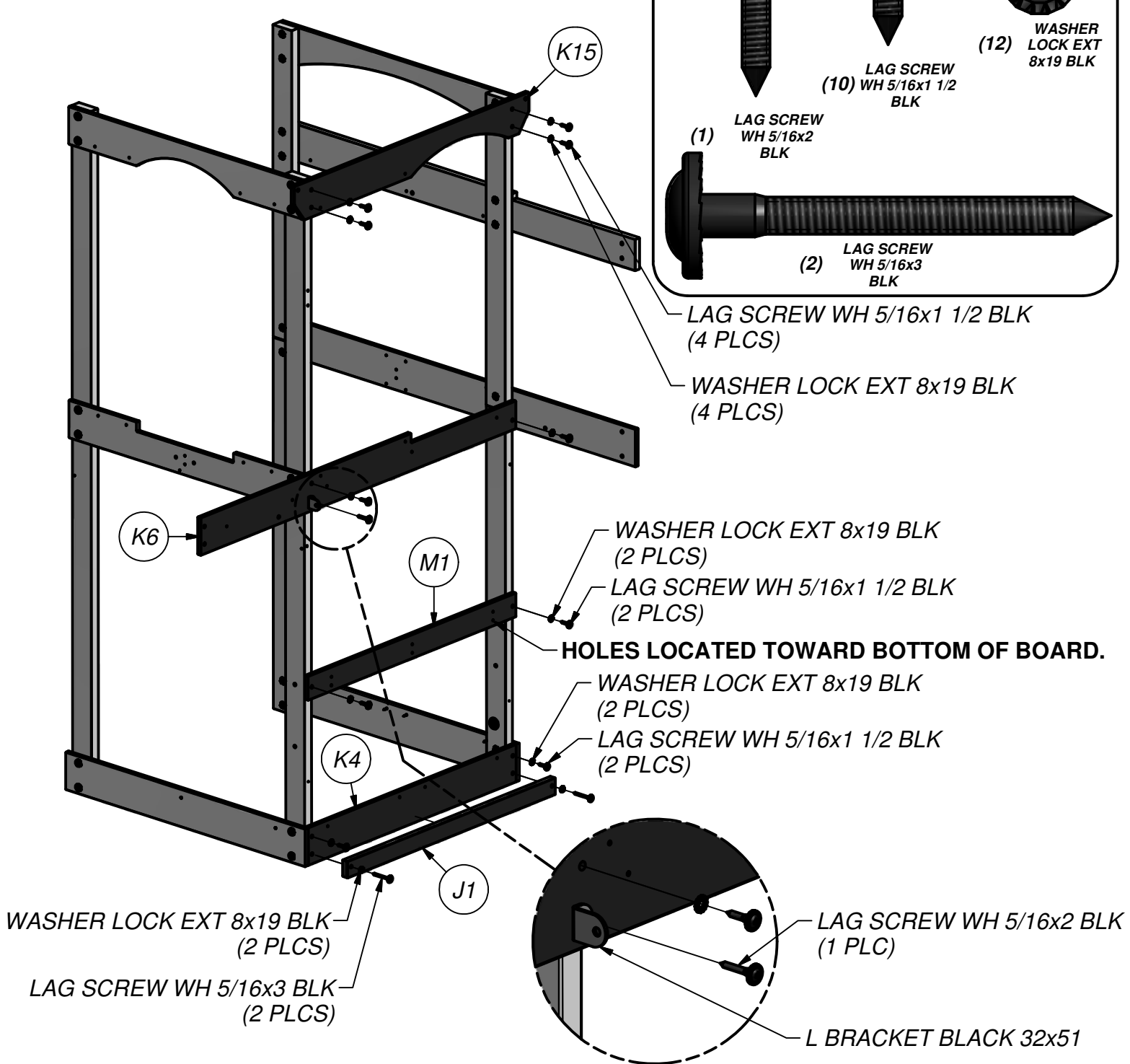

(1) **K3 - GROUND BOARD - W4L07491**
5/8"x5 1/4"x40 1/2" (16x134x1030)

(1) **K7 - REAR CENTER WALL RAIL - W4L07498**
5/8"x5 1/4"x61 3/8" (16x134x1560)

(1) **K14 - ANGLED WALL RAIL - W4L07581**
5/8"x5 1/4"x45 3/4" (16x134x1162)

STEP 4

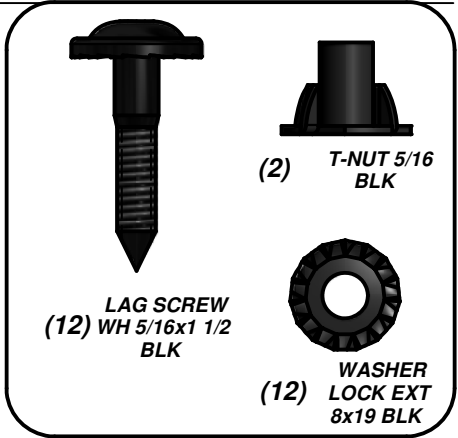
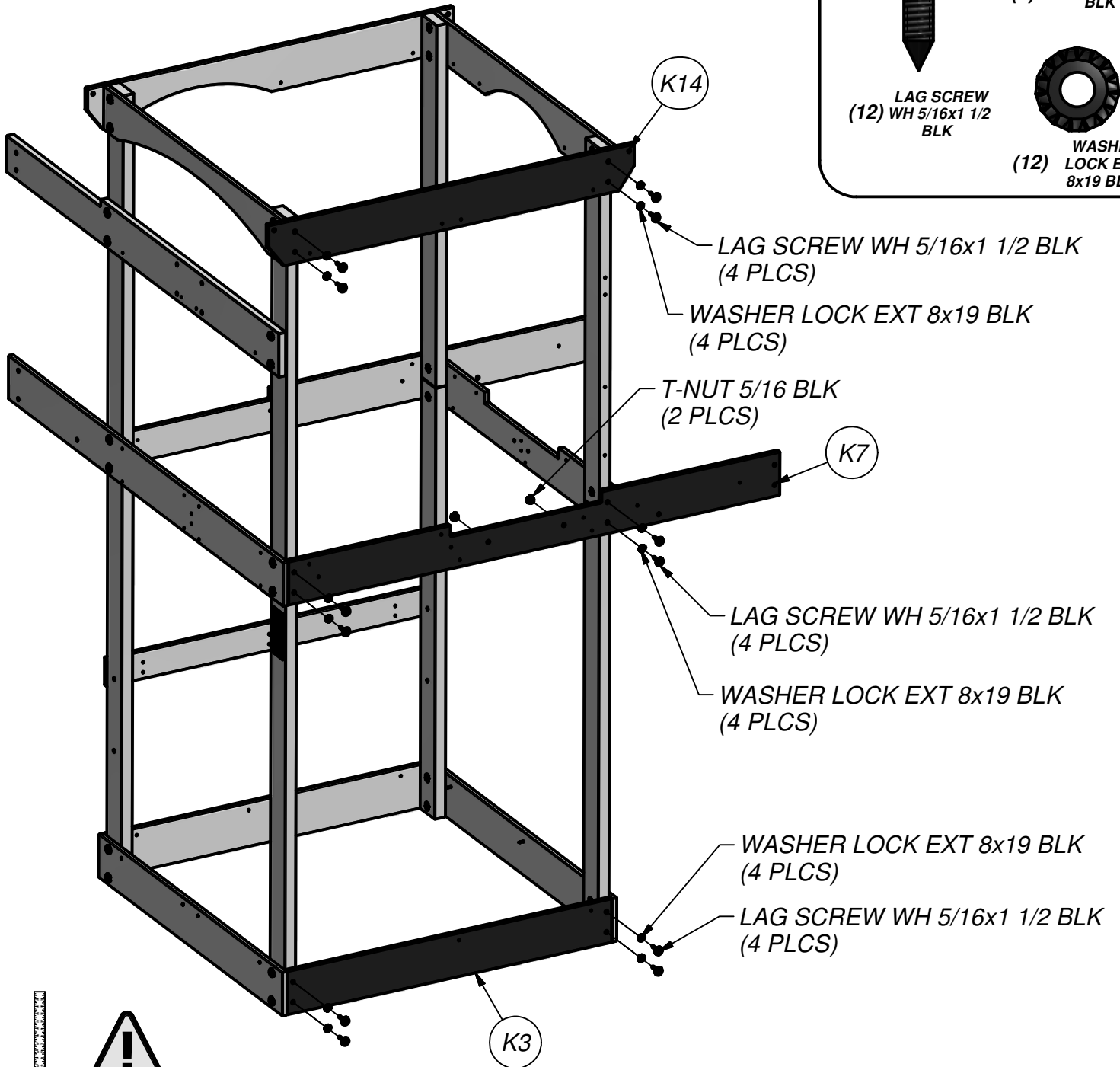



(1) L2 - WALL RAIL - W4L07515
5/8"x4 3/8"x22 7/8" (16x112x582)



(1) - L BRACKET BLACK 32x51 - A4M00710

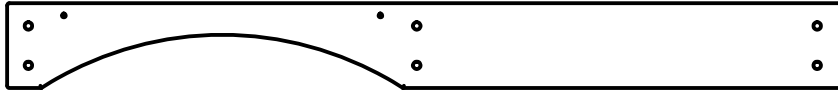

(1) L4 - ARCHED WALL RAIL - W4L07577
5/8"x4 3/8"x43 1/2" (16x112x1106)

STEP 5

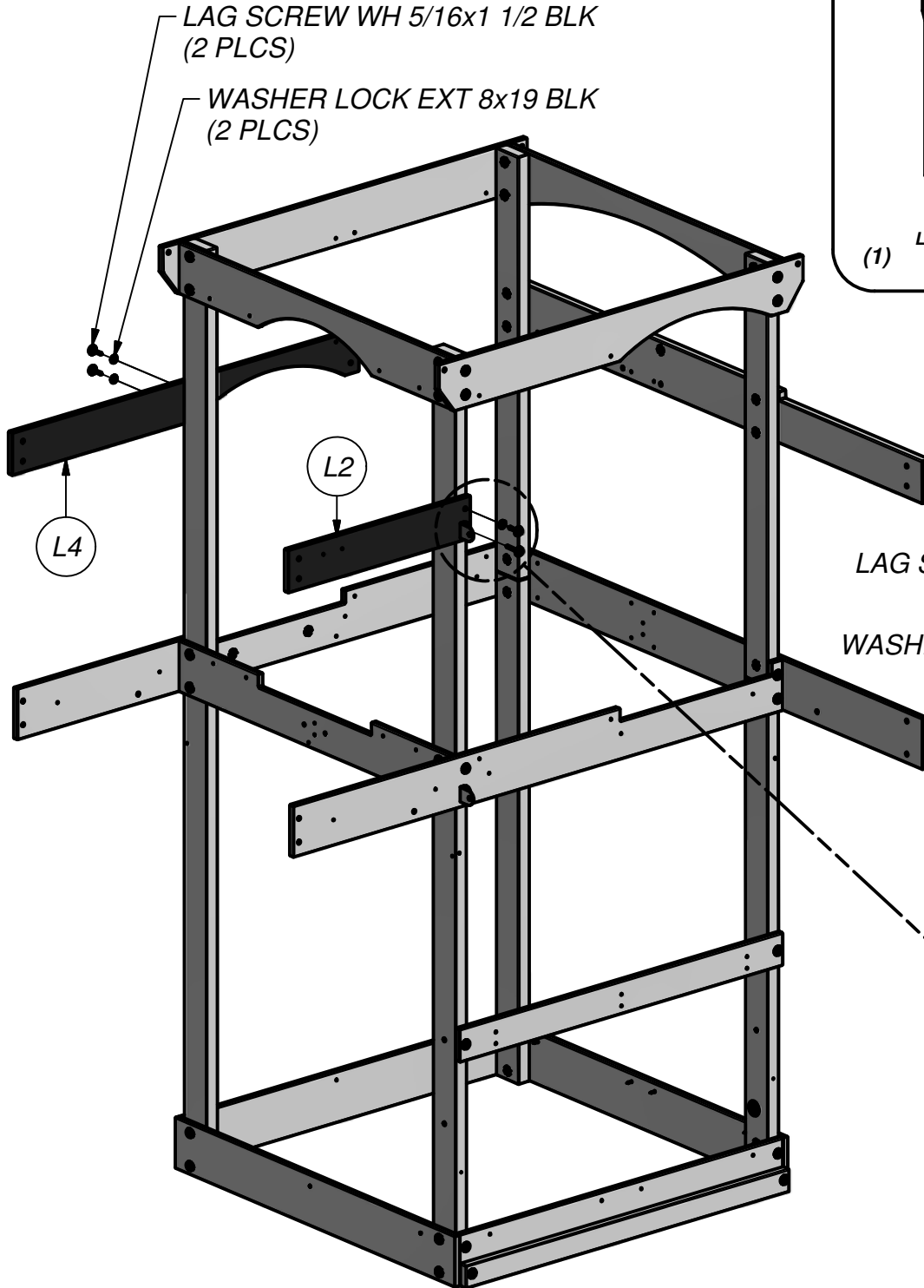

LAG SCREW WH 5/16x1 1/2 BLK
(2 PLCS)

WASHER LOCK EXT 8x19 BLK
(2 PLCS)

L2

L4

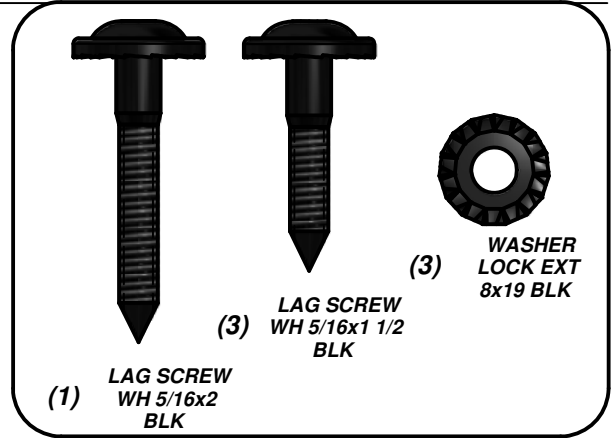

(1) LAG SCREW
WH 5/16x2
BLK

(3) LAG SCREW
WH 5/16x1 1/2
BLK



(3) WASHER
LOCK EXT
8x19 BLK

LAG SCREW WH 5/16x1 1/2 BLK
(1 PLC)

WASHER LOCK EXT 8x19 BLK
(1 PLC)

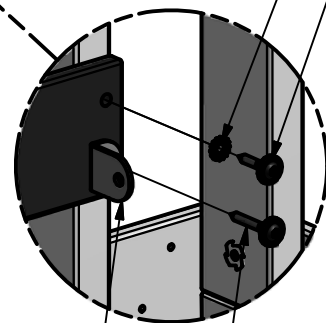

L BRACKET BLACK 32x51

LAG SCREW WH 5/16x2 BLK
(1 PLC)



(1) **F1 - RIGHT BALCONY UPRIGHT - W4L07506**
1 3/8"x2 3/8"x31 3/4" (36x60x805)



(1) **F2 - LEFT BALCONY UPRIGHT - W4L07507**
1 3/8"x2 3/8"x31 3/4" (36x60x805)

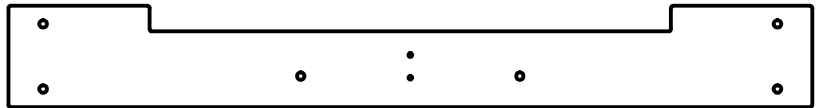

(1) **K11 - LEFT SIDE WALL BOARD - W4L07508**
5/8"x5 1/4"x41 7/8" (16x134x1064)



(1) **L5 - ARCHED WALL RAIL - W4L07578**
5/8"x4 3/8"x40 5/8" (16x112x1032)

STEP 6
INSTALL T-NUTS INTO PARTS BEFORE
ASSEMBLY OF PARTS.

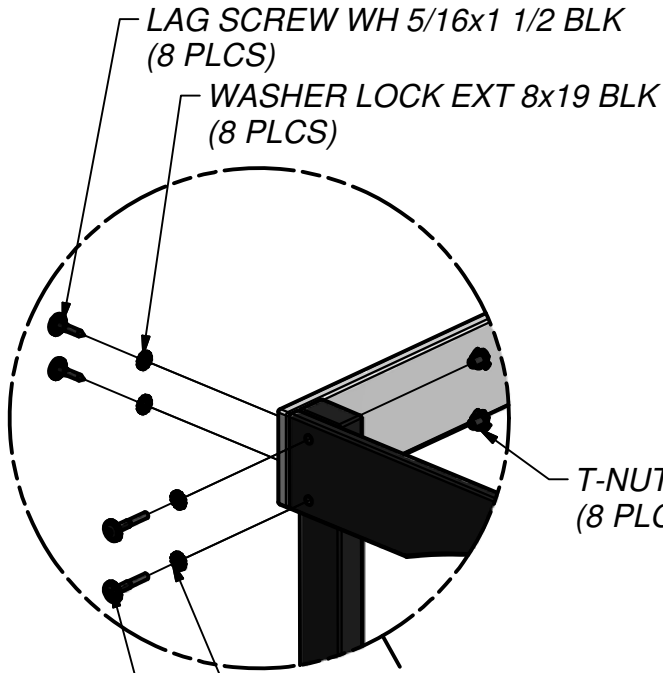
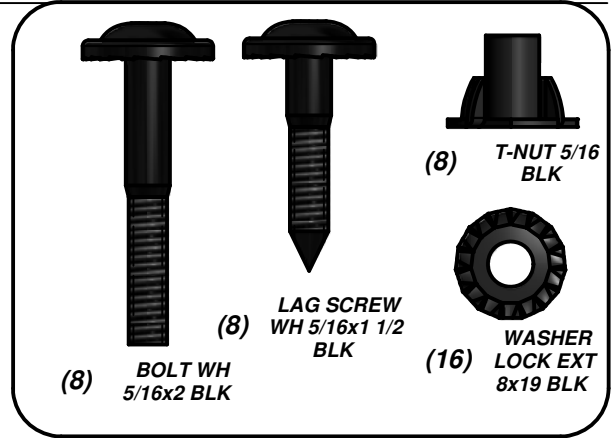

BOLT WH 5/16x2 BLK
(8 PLCS)
WASHER LOCK EXT 8x19 BLK
(8 PLCS)

NARROW EDGES WITH HOLES FACE OUT.
NOTE HOLE ORIENTATION.

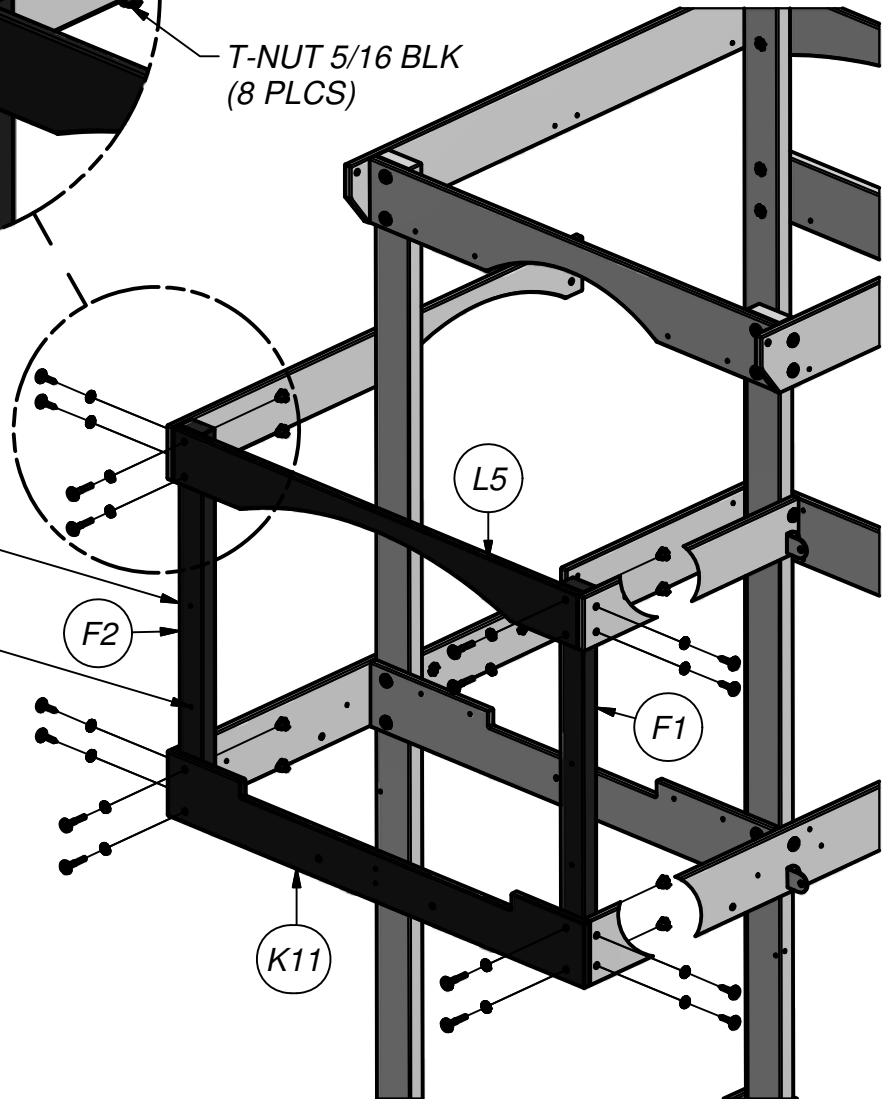



(2) **H4 - DECK BRACE - W4L07616**
 1"x3 3/8"x12 3/4" (24x86x325)

STEP 7
INSTALL T-NUTS INTO PARTS BEFORE ASSEMBLY OF PARTS.

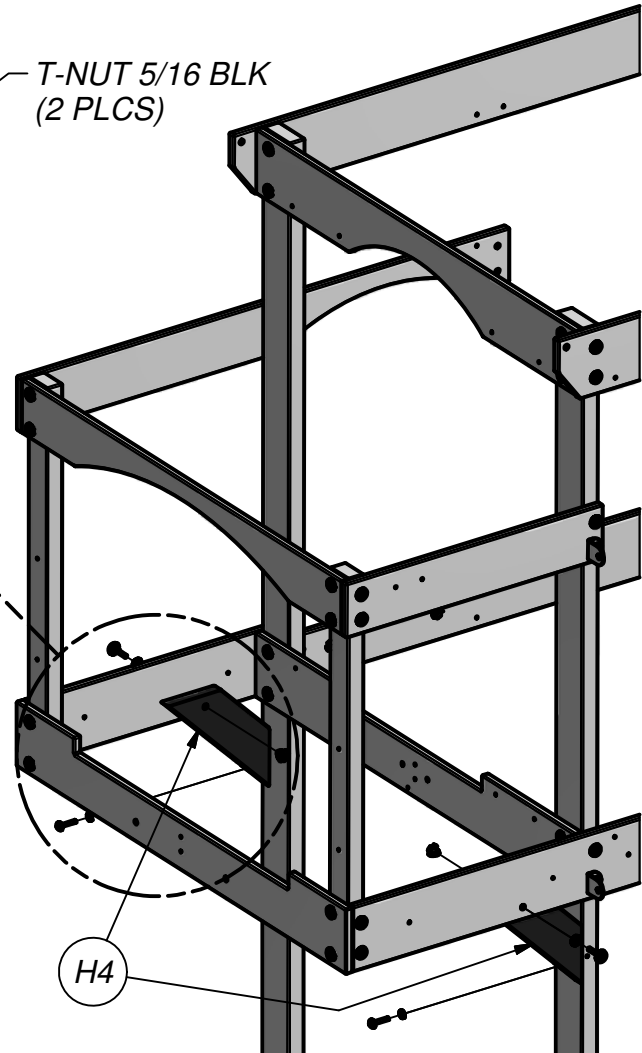
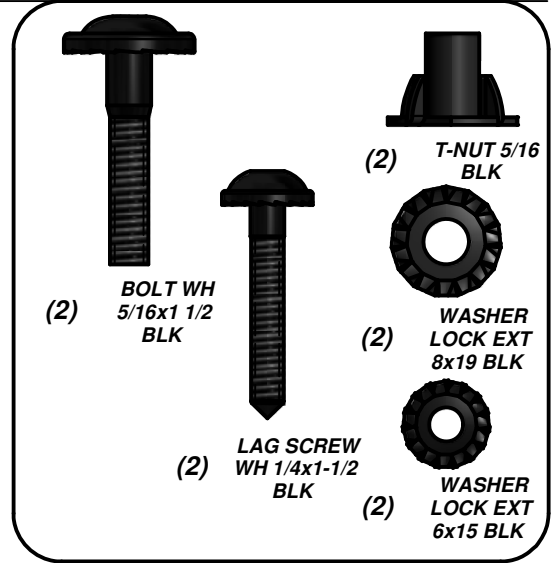
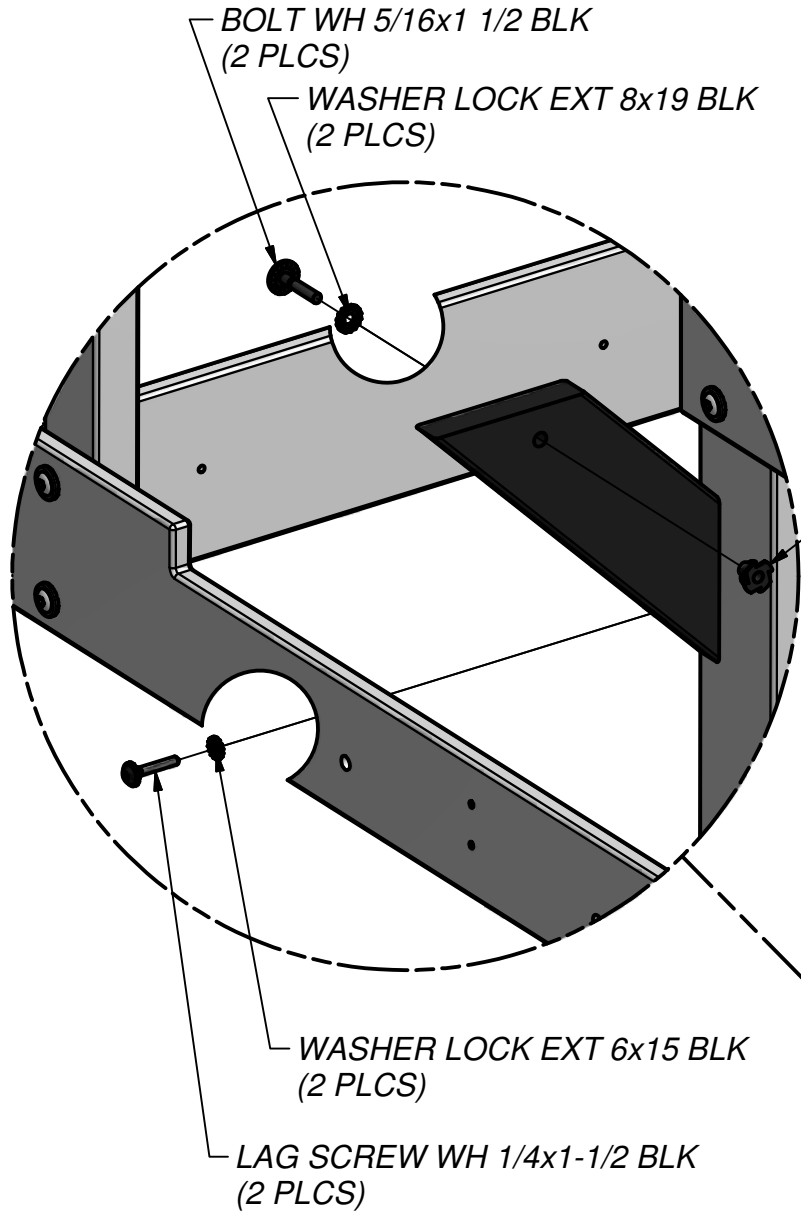



(1) **K9 - LEFT BALCONY WALL RAIL - W4L07500**
5/8"x5 1/4"x20 3/4" (16x134x528)

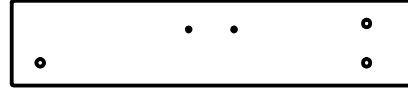

(1) **L3 - WALL RAIL - W4L07576**
5/8"x4 3/8"x20 7/8" (16x112x529)

STEP 8

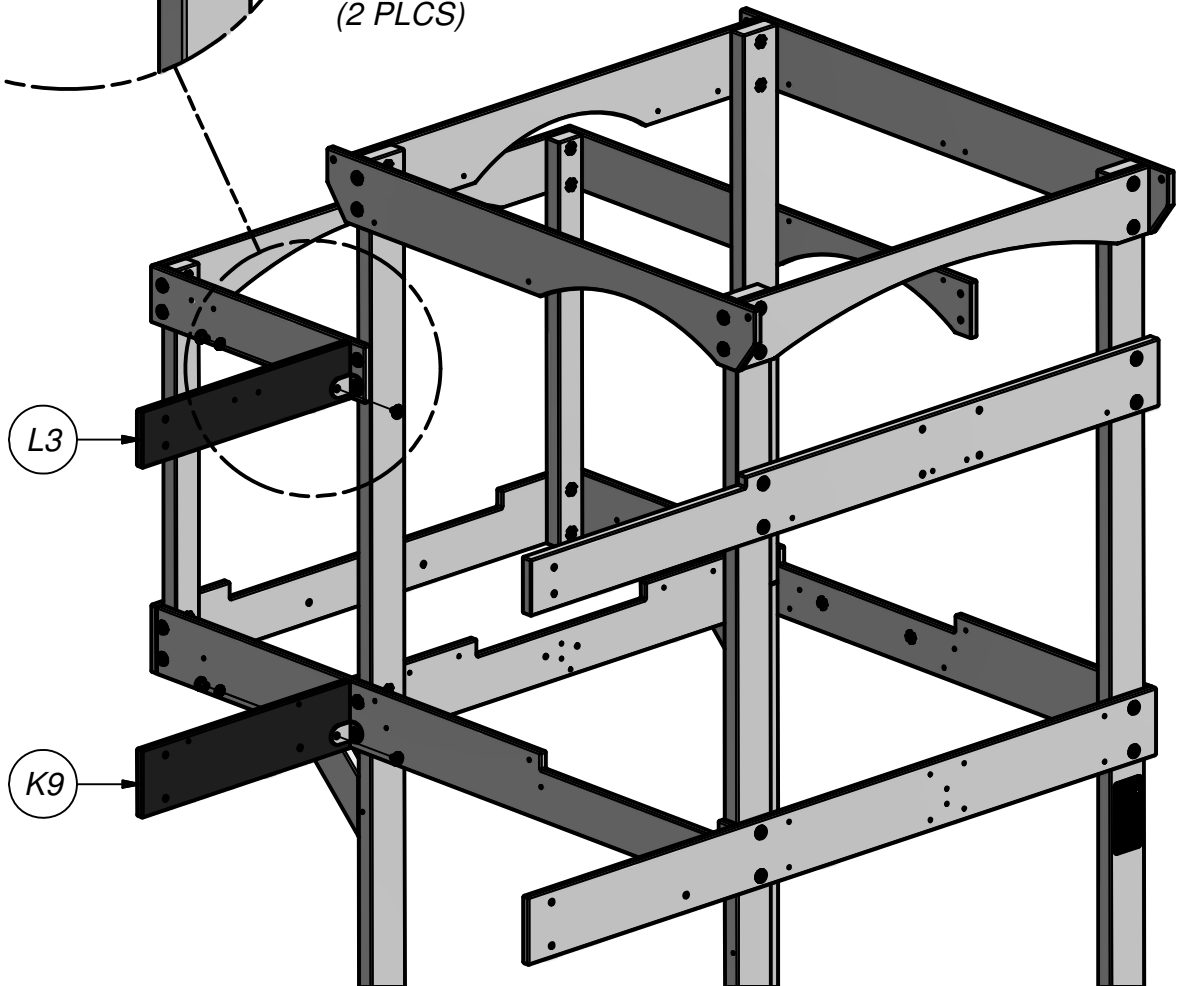
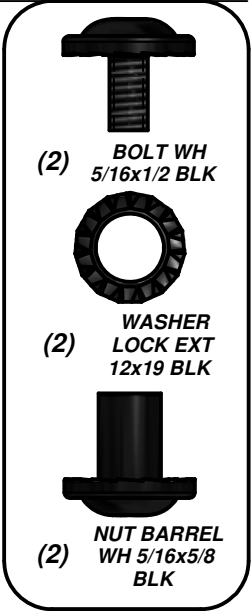
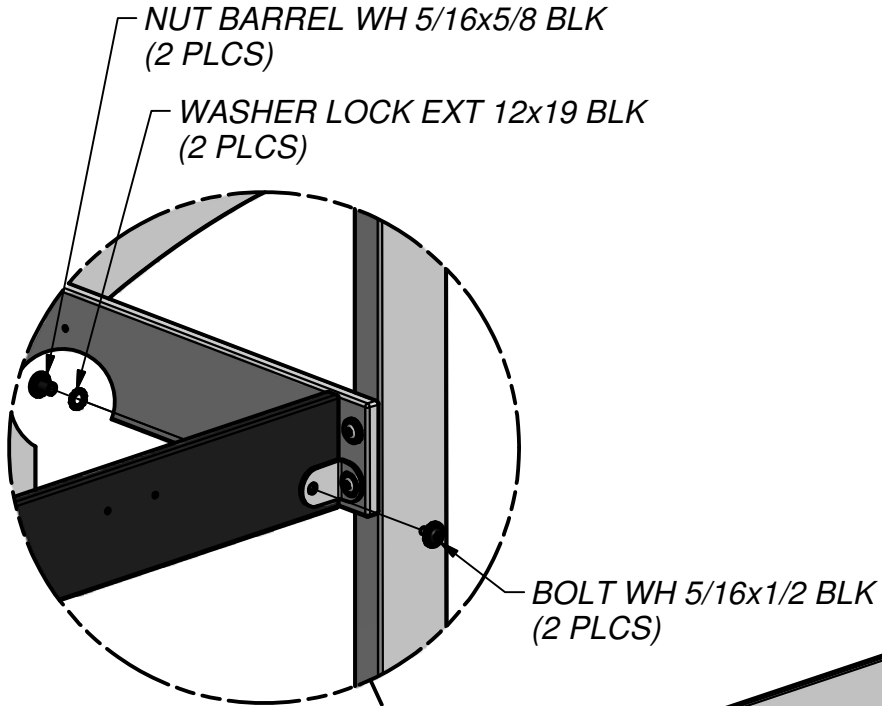

(1) E5 - RIGHT FRONT BALCONY UPRIGHT - W4L07502
1 3/8"x3 3/8"x80 3/4" (36x86x2052)

(1) E11 - RIGHT FRONT BALCONY UPRIGHT - W4L07673
1 3/8"x3 3/8"x80 3/4" (36x86x2052)

(2) N1 - PORCH GROUND BOARD - W4L07503
5/8"x2 3/8"x21 1/8" (16x60x537)

STEP 9

INSTALL T-NUTS INTO PARTS BEFORE ASSEMBLY OF PARTS.

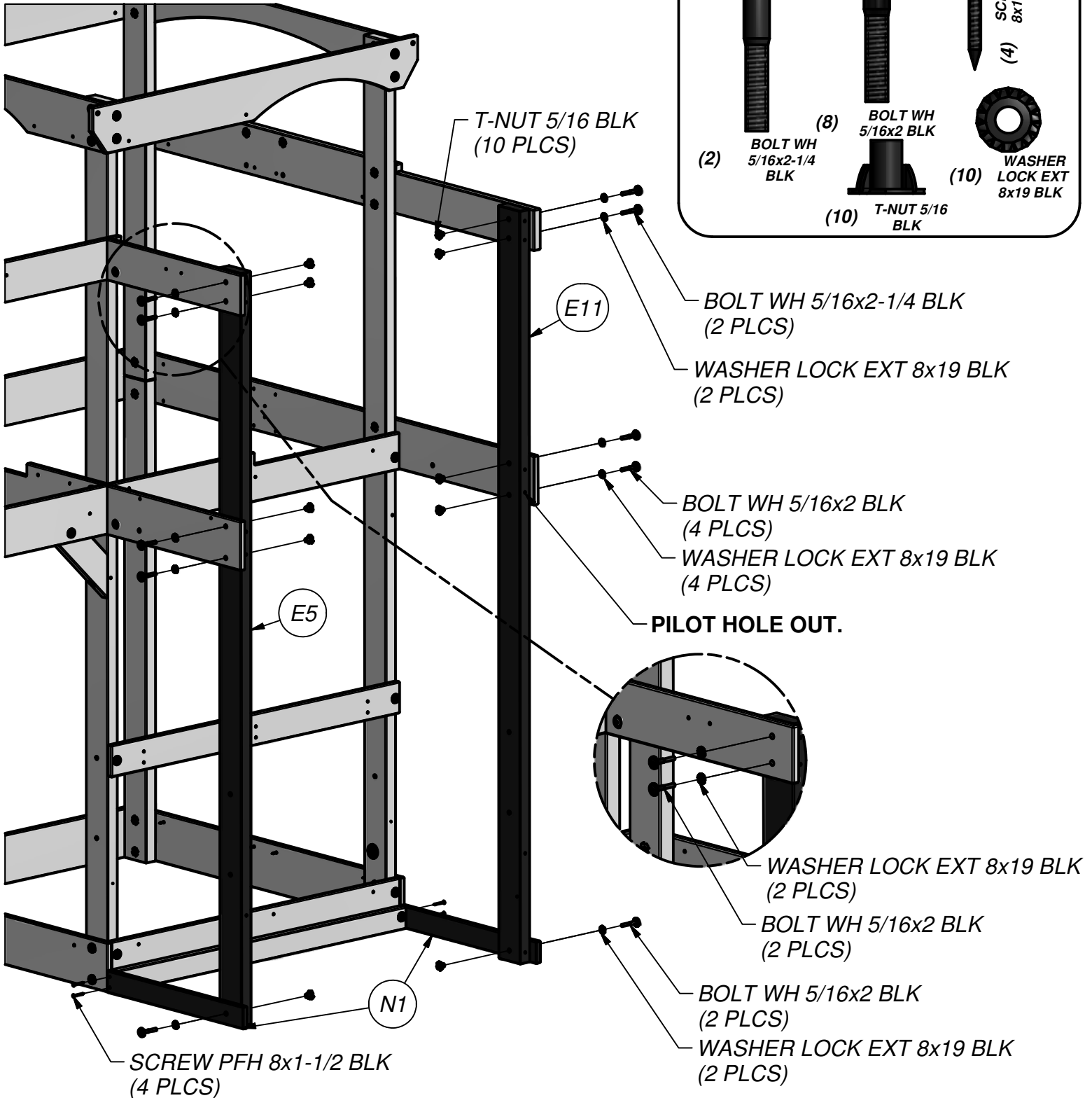

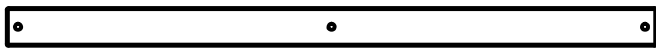

(1) **J2 - PORCH GROUND BOARD - W4L07505**
1"x2 3/8"x40 5/8" (24x60x1032)

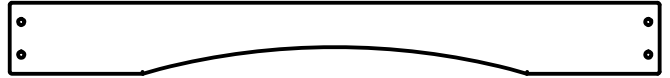

(1) **L1 - ARCHED WALL RAIL - W4L07514**
5/8"x4 3/8"x40 5/8" (16x112x1032)

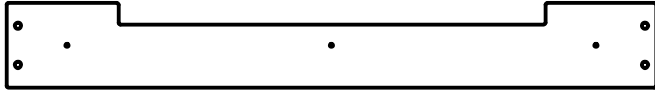

(1) **K10 - FRONT BALCONY WALL RAIL - W4L07501**
5/8"x5 1/4"x40 5/8" (16x134x1032)

STEP 10

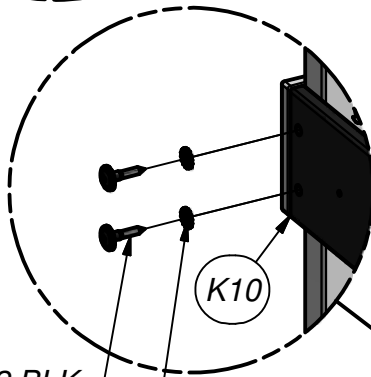
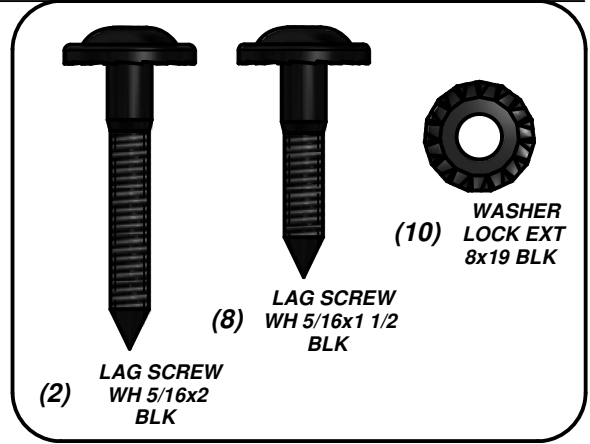
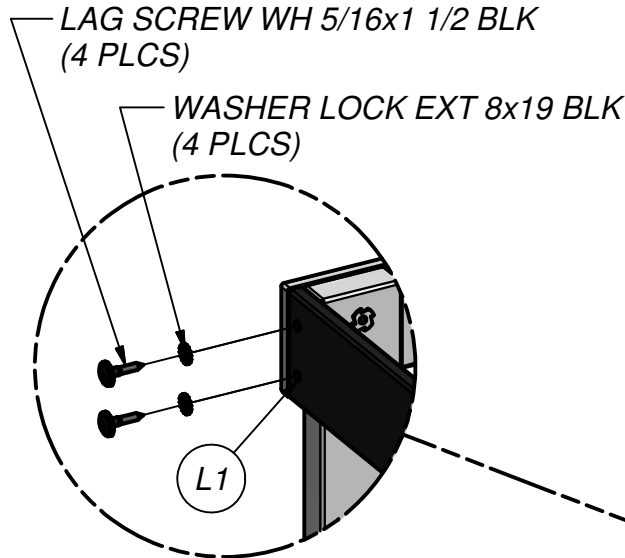

LAG SCREW WH 5/16x1 1/2 BLK (4 PLCS)

WASHER LOCK EXT 8x19 BLK (4 PLCS)

WASHER LOCK EXT 8x19 BLK (2 PLCS)

LAG SCREW WH 5/16x2 BLK (2 PLCS)

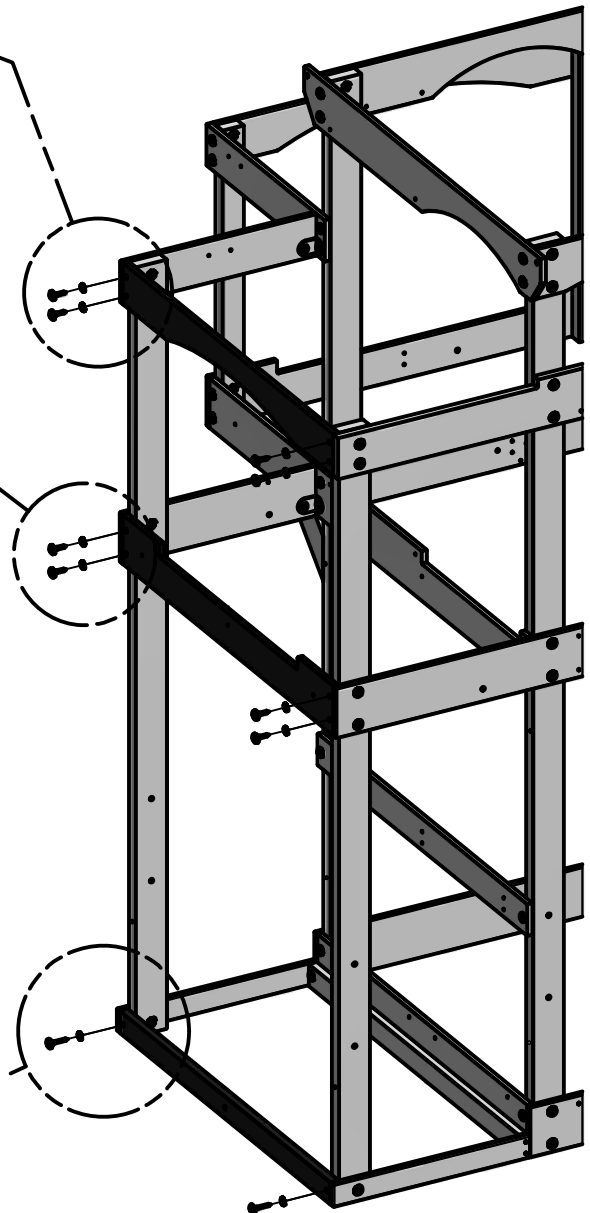
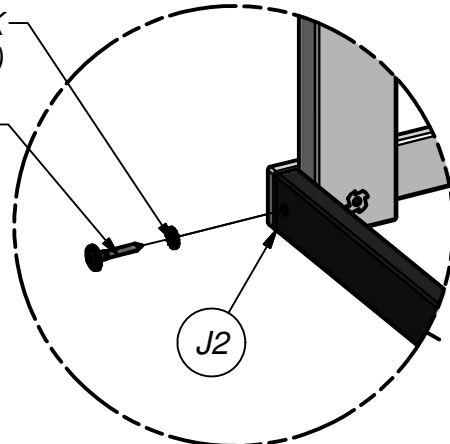



(2) **H4 - DECK BRACE - W4L07616**
 1"x3 3/8"x12 3/4" (24x86x325)

STEP 11
INSTALL T-NUTS INTO PARTS BEFORE ASSEMBLY OF
PARTS.

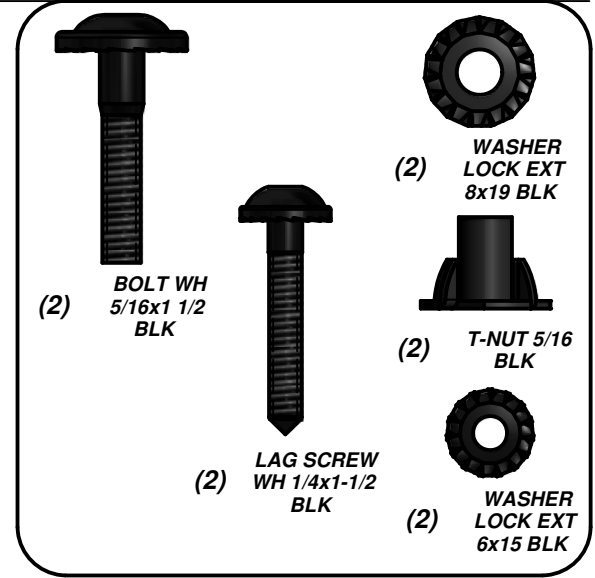
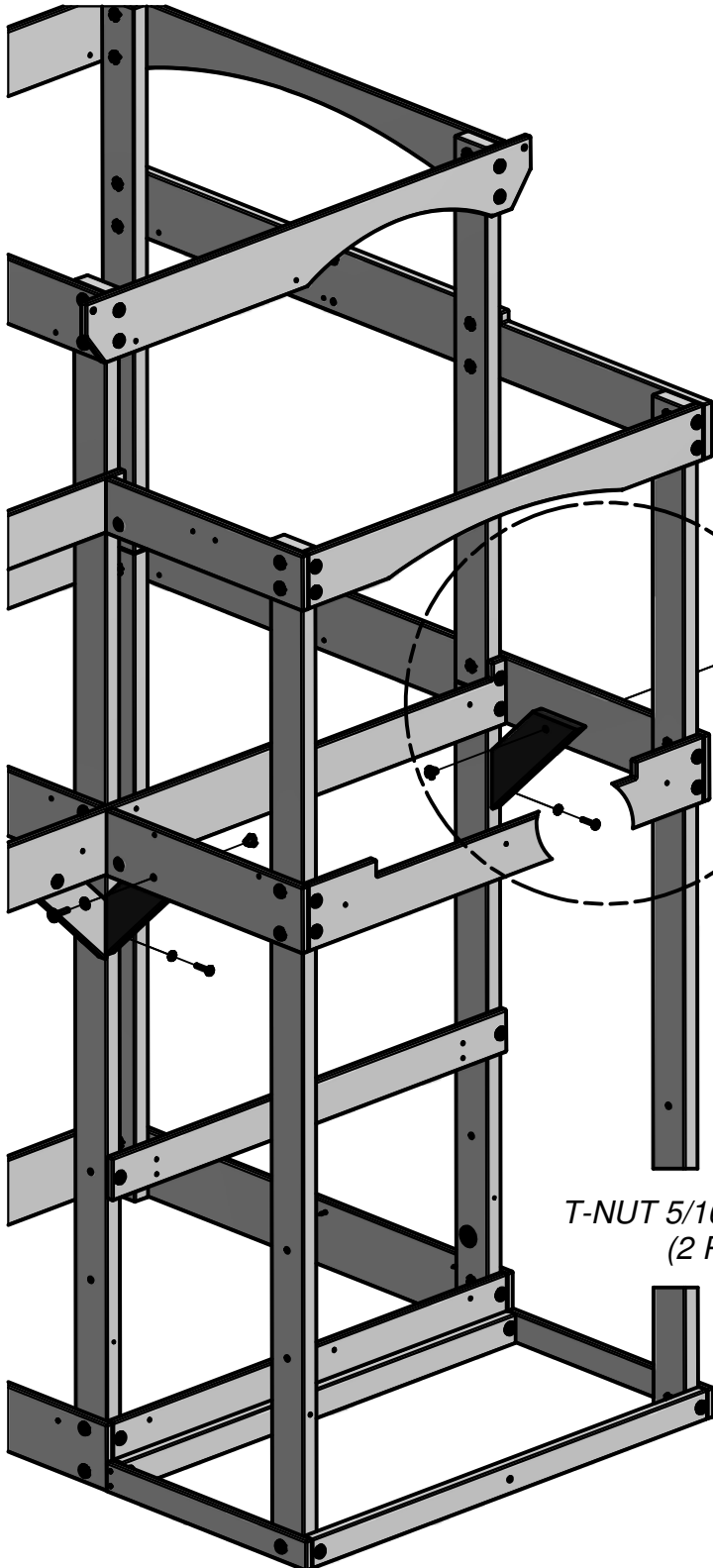

BOLT WH 5/16x1 1/2 BLK
 (2 PLCS)

WASHER LOCK EXT 8x19 BLK
 (2 PLCS)

T-NUT 5/16 BLK
 (2 PLCS)

WASHER LOCK EXT 6x15 BLK
 (2 PLCS)

LAG SCREW WH 1/4x1-1/2 BLK
 (2 PLCS)



(1) J8 - FLOOR JOIST - W4L07602
1"x2 3/8"x40 1/2" (24x60x1029)

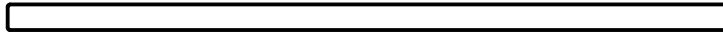

(2) T1 - SUPPORT BOARD - W4L07599
1"x1 3/8"x37 5/8" (24x34x957)

STEP 12

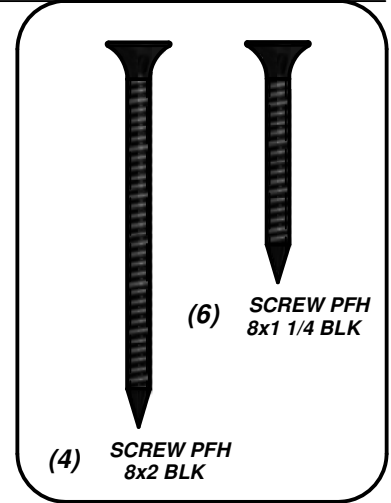
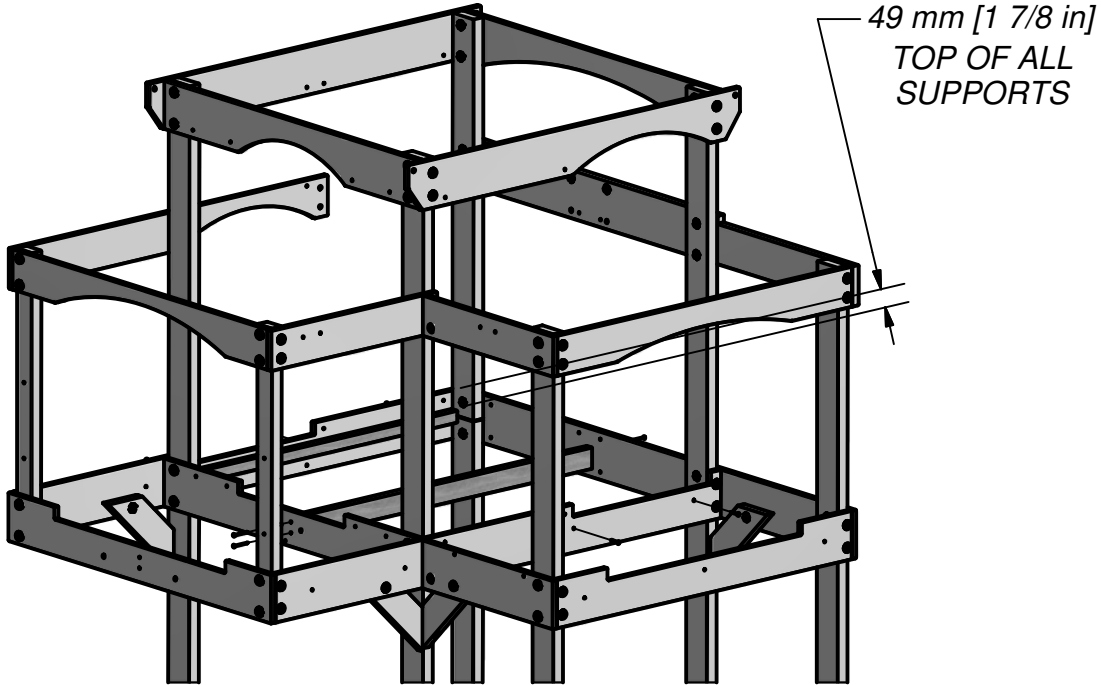

SCREW PFH 8x1 1/4 BLK
(3 PLCS)

SCREW PFH 8x2 BLK
(2 PLCS)

SCREW PFH 8x2 BLK
(2 PLCS)

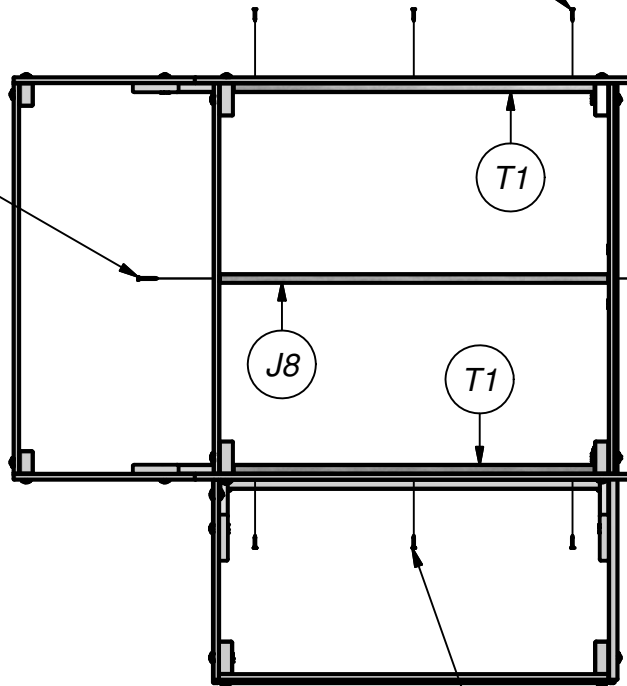

TOP VIEW

SCREW PFH 8x1 1/4 BLK
(3 PLCS)



(1) **J9 - FLOOR JOIST - W4L07603**
1"x2 3/8"x20 1/4" (24x60x513)



(2) **T3 - SUPPORT BOARD - W4L07601**
1"x1 3/8"x18 3/4" (24x34x477)

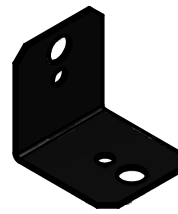

(2) - **90° L-BRACKET - BLK - A4M00555**

STEP 13

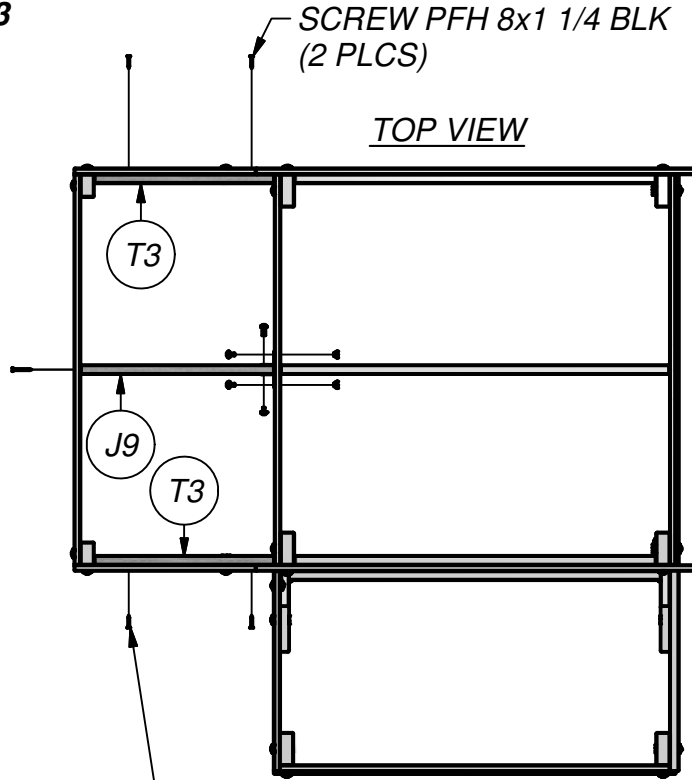

SCREW PFH 8x1 1/4 BLK
(2 PLCS)

TOP VIEW

T3

J9

T3

SCREW PFH 8x1 1/4 BLK
(2 PLCS)

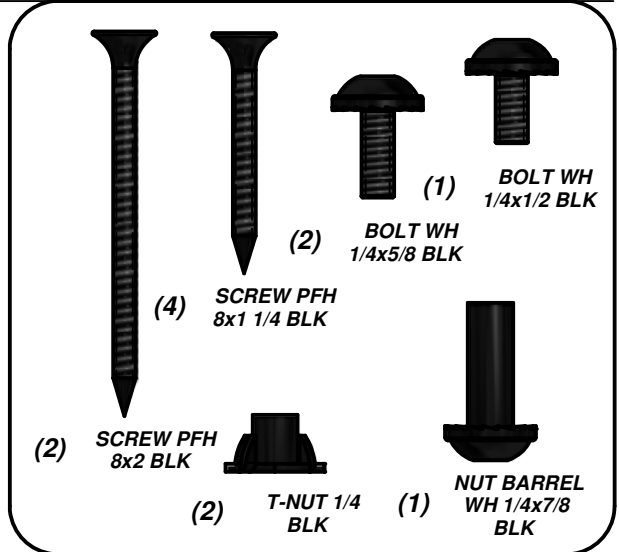

(4) SCREW PFH 8x1 1/4 BLK
(2) SCREW PFH 8x2 BLK
(2) BOLT WH 1/4x5/8 BLK
(1) BOLT WH 1/4x1/2 BLK
(2) T-NUT 1/4 BLK
(1) NUT BARREL WH 1/4x7/8 BLK

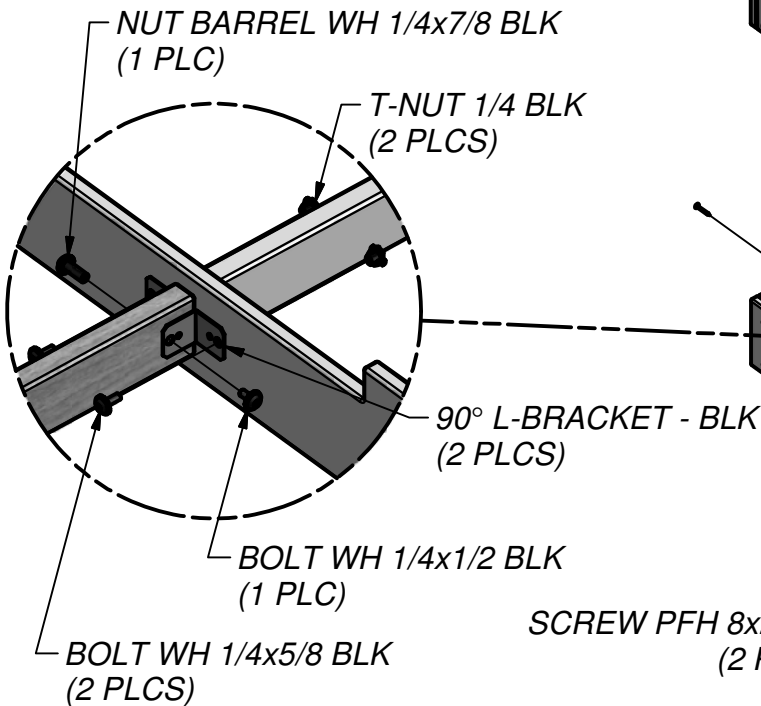

NUT BARREL WH 1/4x7/8 BLK
(1 PLC)

T-NUT 1/4 BLK
(2 PLCS)

90° L-BRACKET - BLK
(2 PLCS)

BOLT WH 1/4x1/2 BLK
(1 PLC)

BOLT WH 1/4x5/8 BLK
(2 PLCS)

SCREW PFH 8x2 BLK
(2 PLCS)

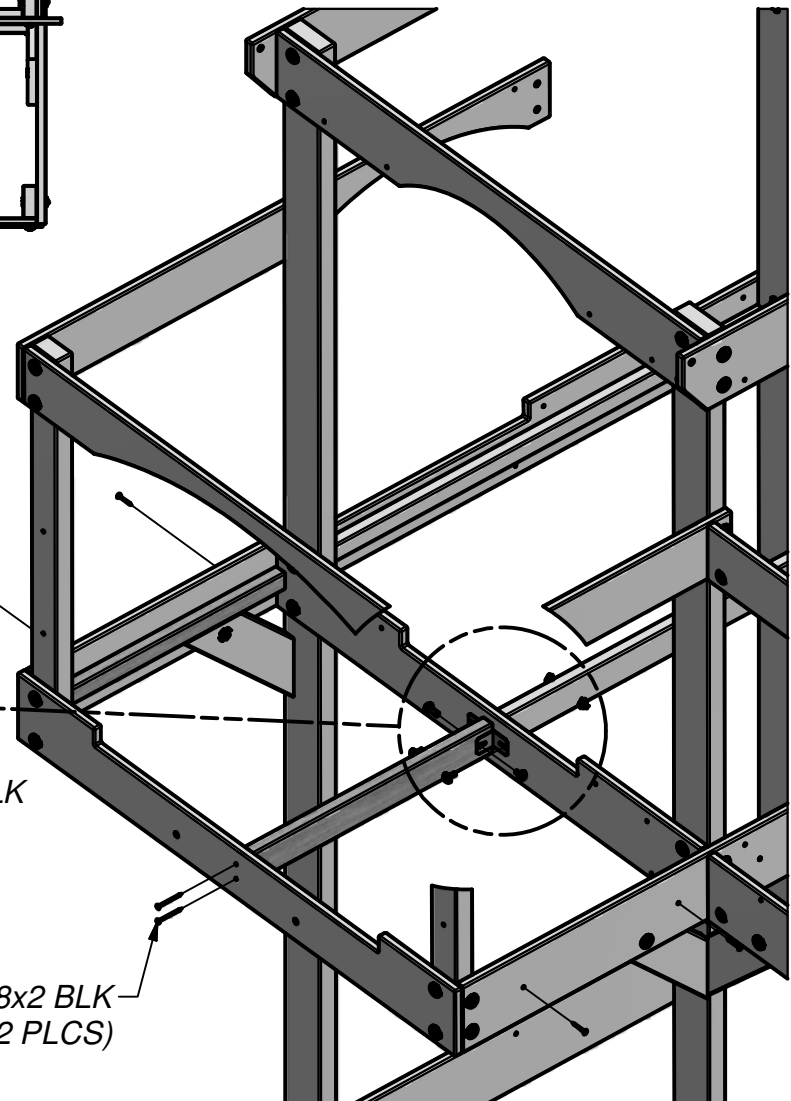

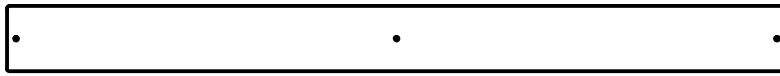

(10) **M11 - FLOOR BOARD - W4L07610**
5/8"x3 3/8"x40 5/8" (16x86x1031)



(2) **M12 - FLOOR BOARD - W4L07611**
5/8"x3 3/8"x40 5/8" (16x86x1031)

STEP 14

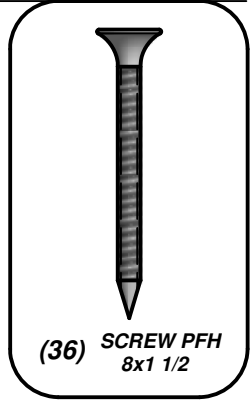
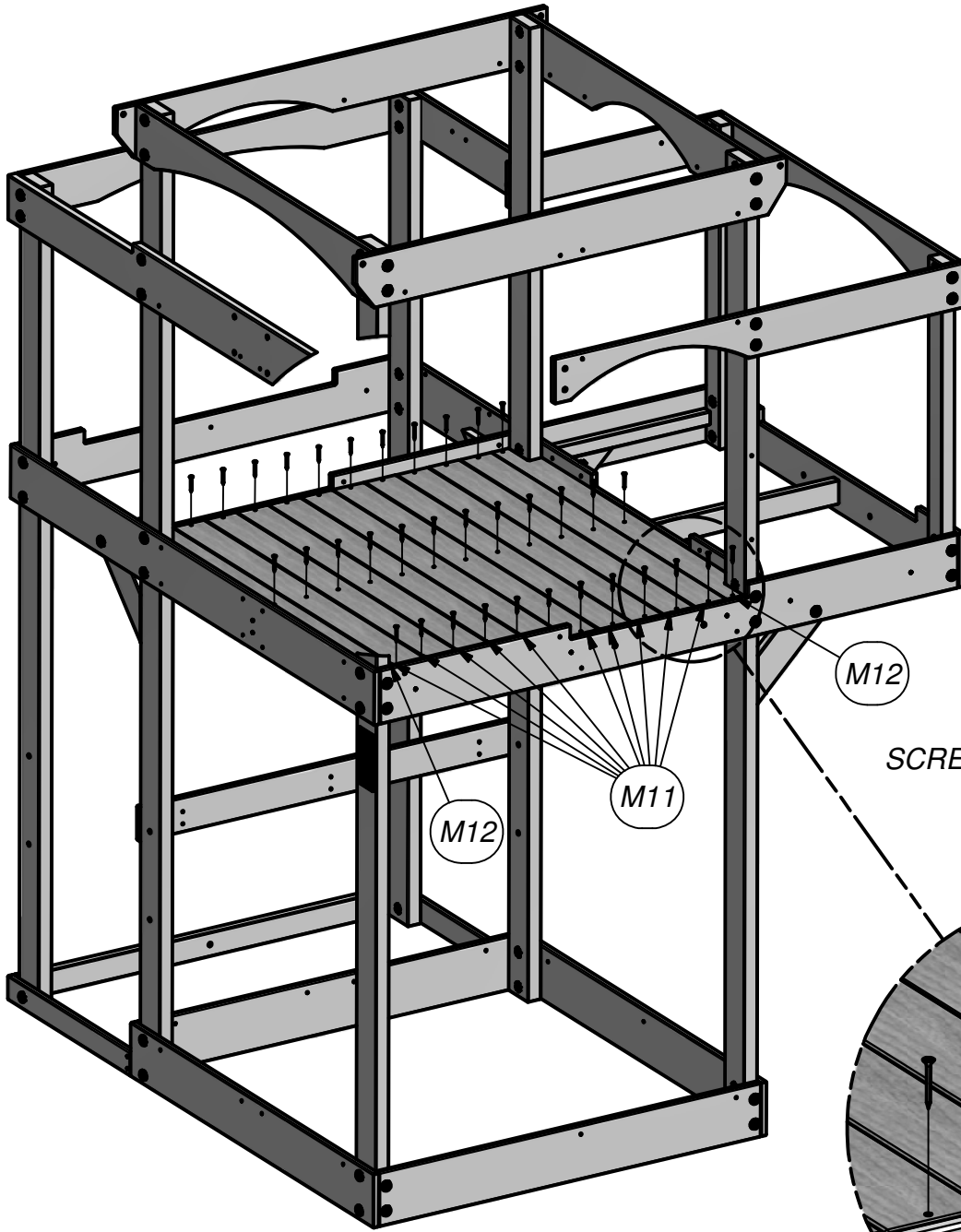

SCREW PFH 8x1 1/2
(36 PLCS)

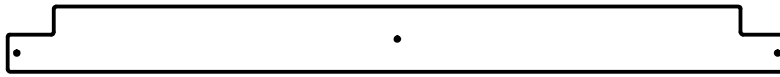

(1) M10 - FLOOR BOARD - W4L07609
5/8"x3 3/8"x40 5/8" (16x86x1031)



(5) M11 - FLOOR BOARD - W4L07610
5/8"x3 3/8"x40 5/8" (16x86x1031)

STEP 15

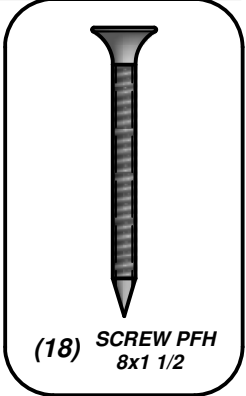
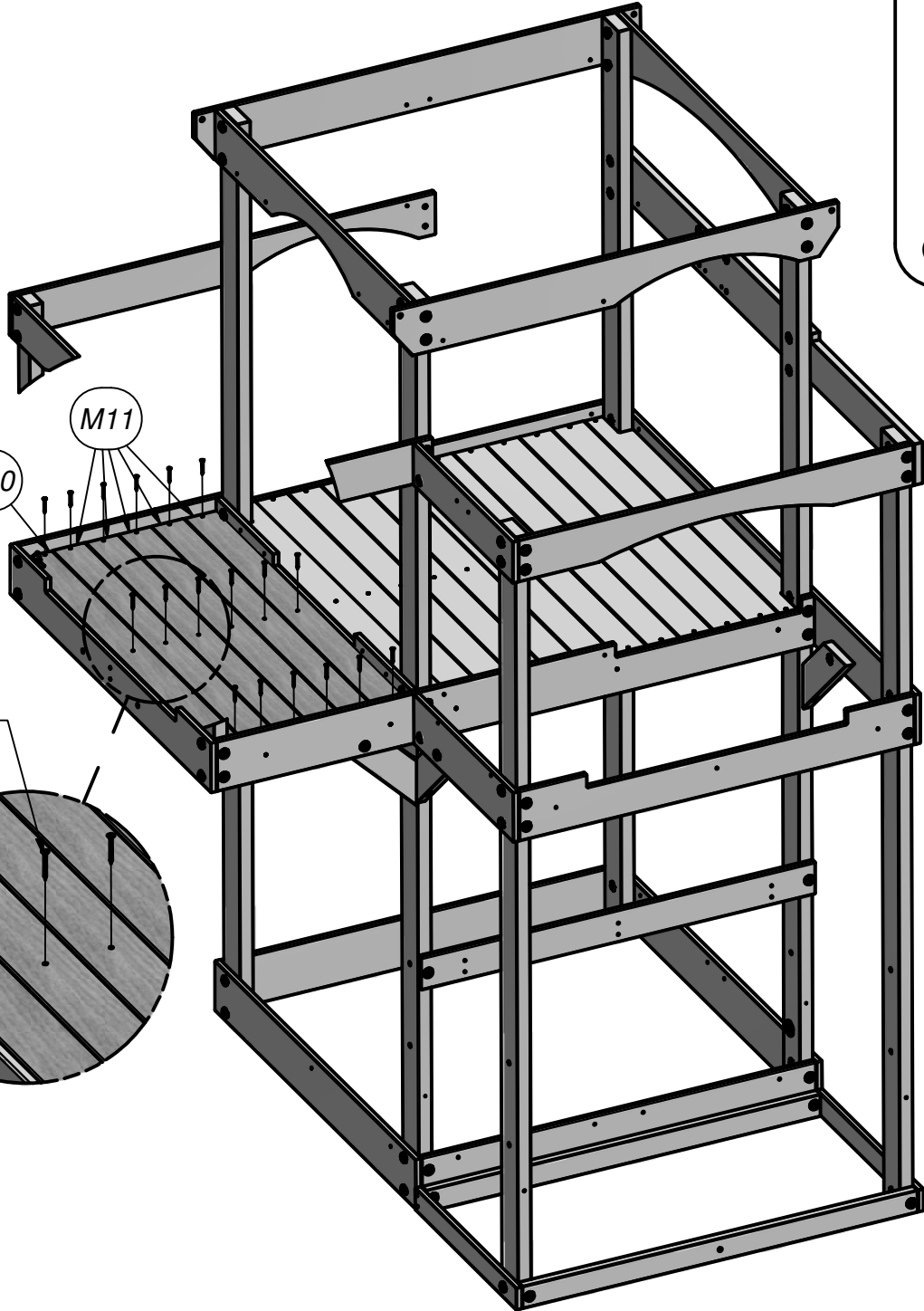

(18) SCREW PFH
8x1 1/2

SCREW PFH 8x1 1/2
(18 PLCS)

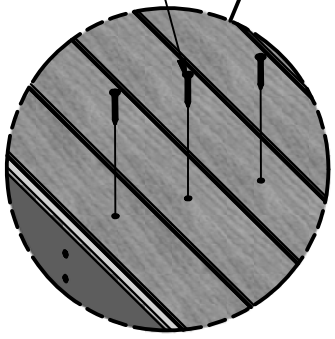

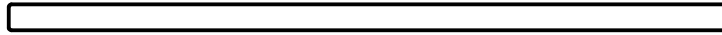

(1) T1 - SUPPORT BOARD - W4L07599
1"x1 3/8"x37 5/8" (24x34x957)



(1) T2 - SUPPORT BOARD - W4L07600
1"x1 3/8"x37 3/4" (24x34x959)

STEP 16

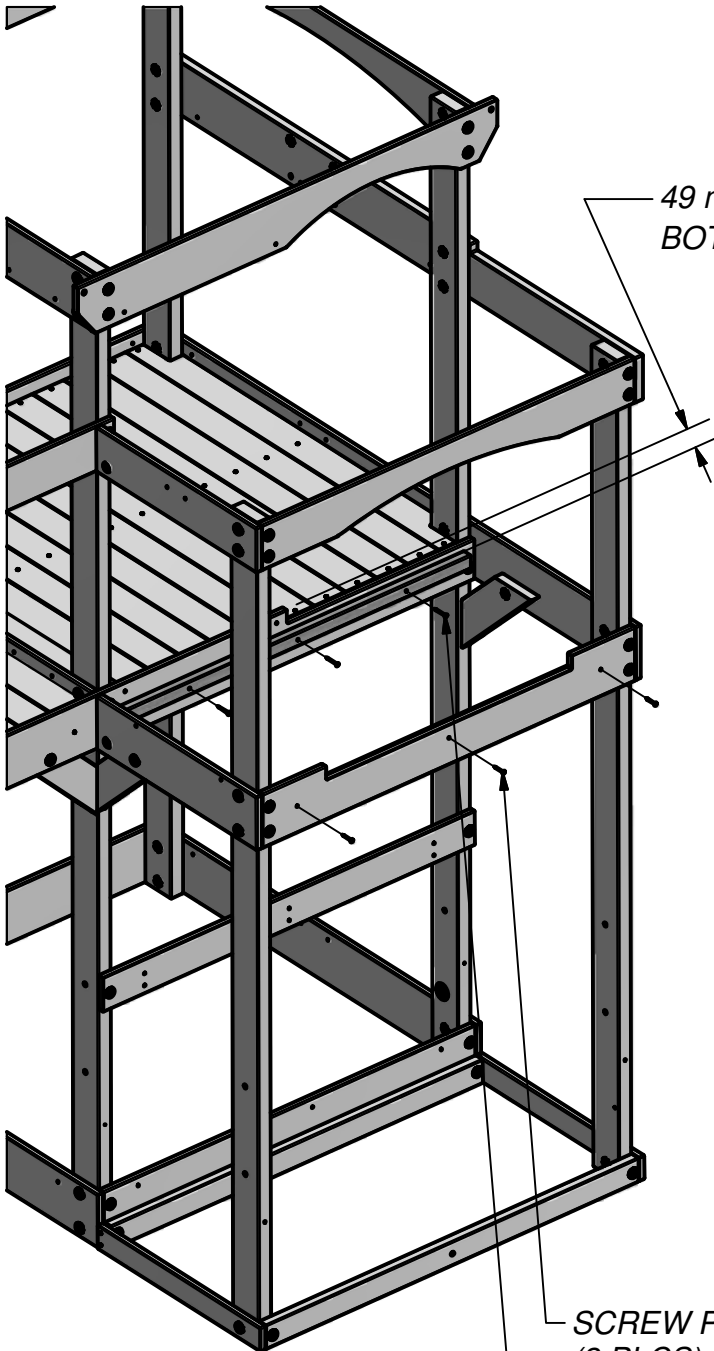

49 mm [1 7/8 in]
BOTH SUPPORTS

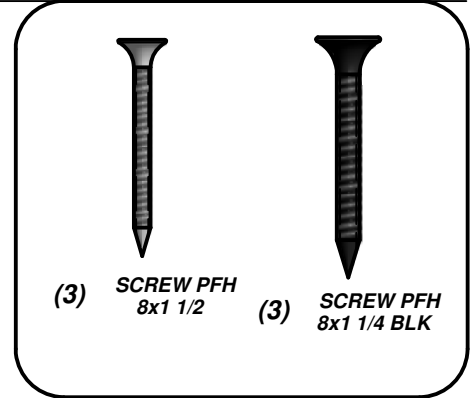

TOP VIEW

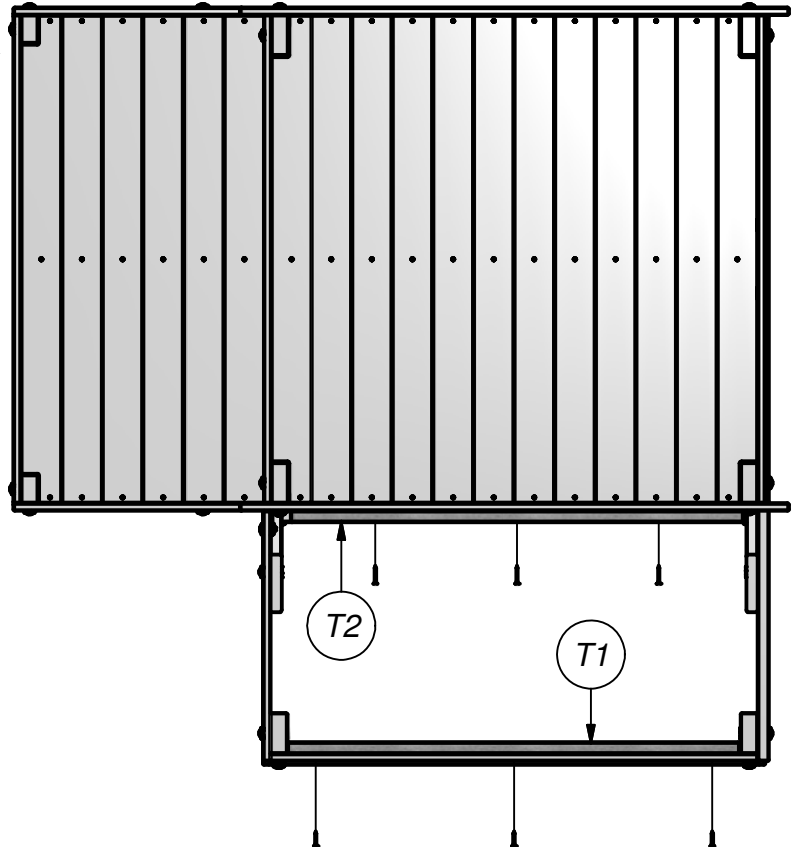

SCREW PFH 8x1 1/4 BLK
(3 PLCS)

SCREW PFH 8x1 1/2
(3 PLCS)



(1) **M8 - FLOOR BOARD - W4L07607**
5/8"x3 3/8"x20 1/8" (16x86x512)



(10) **M9 - FLOOR BOARD - W4L07608**
5/8"x3 3/8"x20 1/8" (16x86x512)



(1) **M13 - FLOOR BOARD - W4L07671**
5/8"x3 3/8"x20 1/8" (16x86x512)

STEP 17

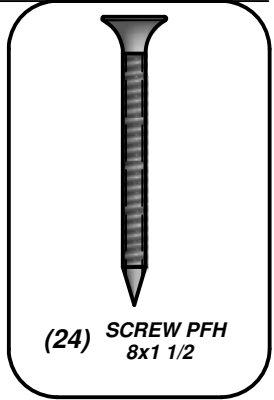
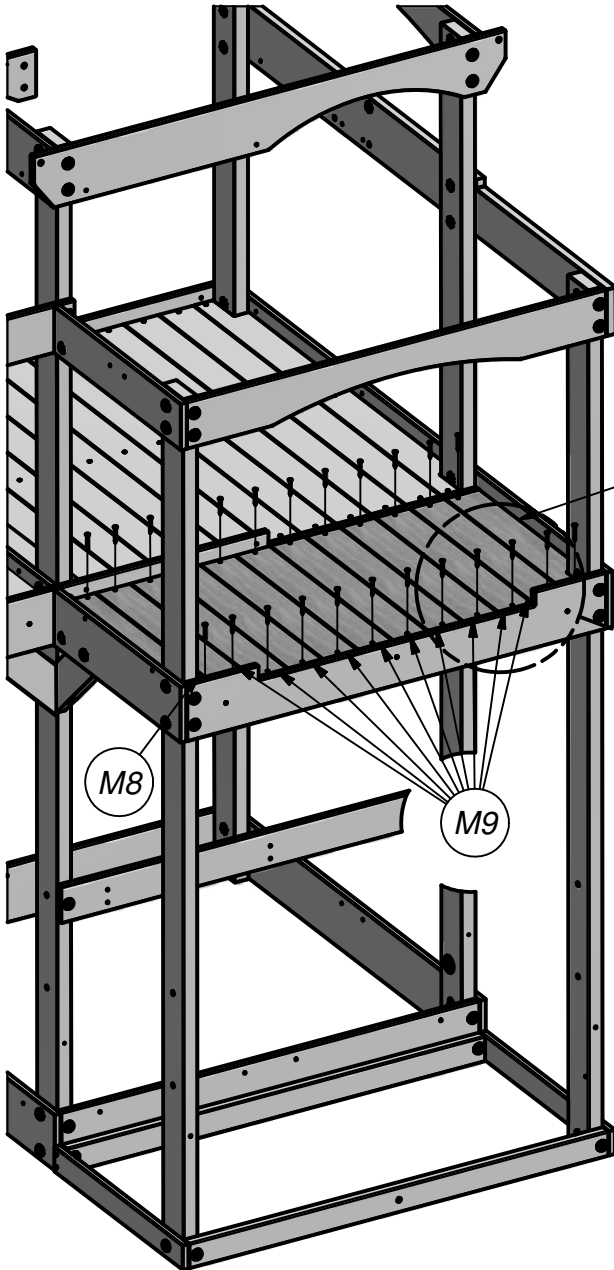

(24) **SCREW PFH**
8x1 1/2

SCREW PFH 8x1 1/2
(24 PLCS)

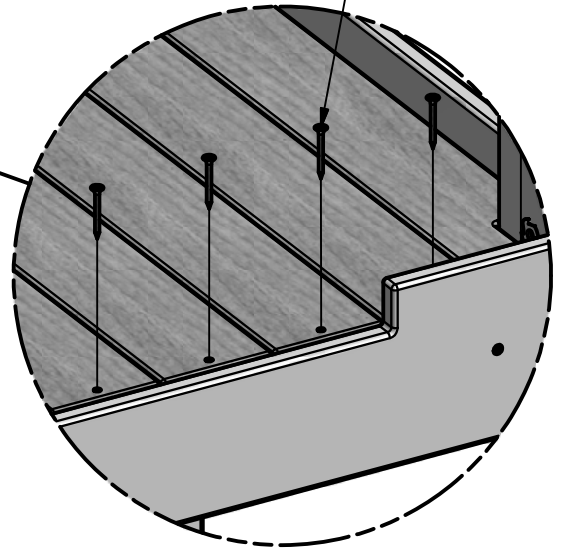

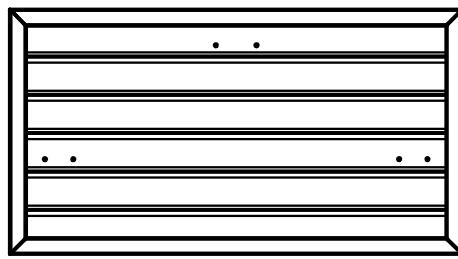

(1) WP1 - FRONT WALL PANEL - W2A02082
1"x20 3/8"x37 3/4" (24x517x958)

STEP 18

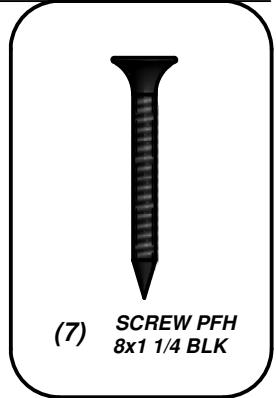
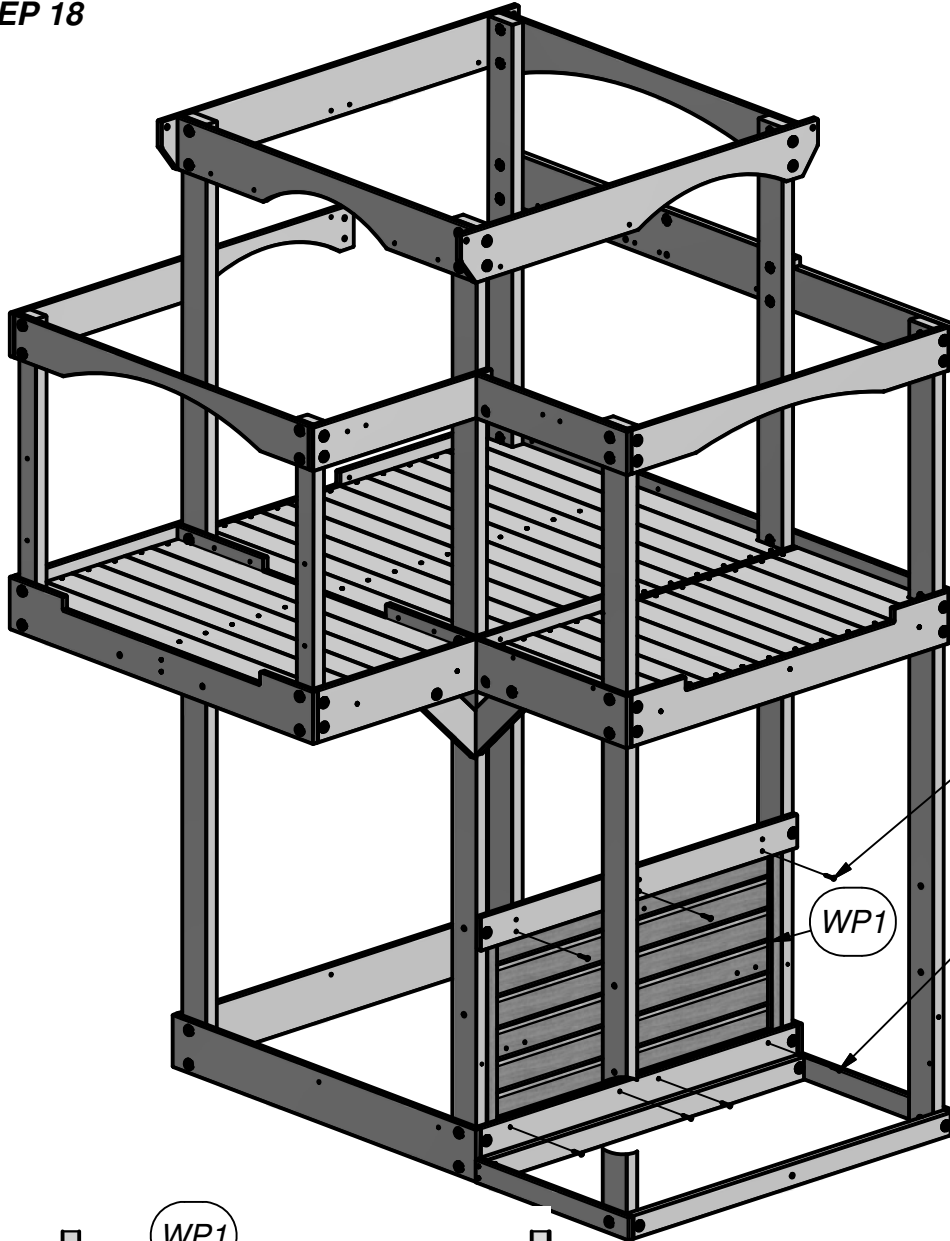

SCREW PFH 8x1 1/4 BLK
(3 PLCS)

WP1

SCREW PFH 8x1 1/4 BLK
(4 PLCS)

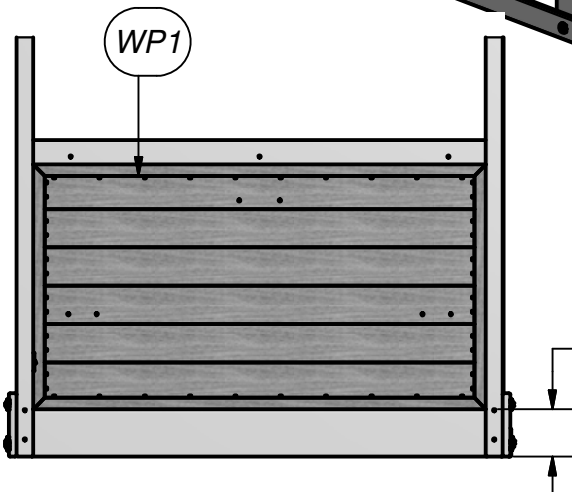

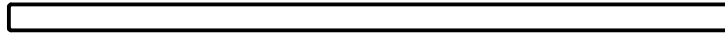

(1) T4 - SUPPORT BOARD - W4L07613
1"x1 3/8"x37 3/4" (24x34x958)

STEP 19

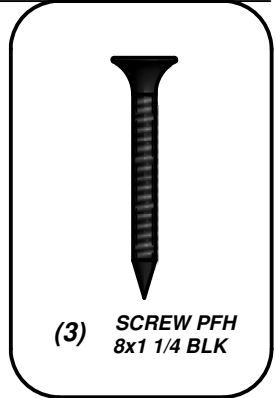

SCREW PFH 8x1 1/4 BLK
(3 PLCS)

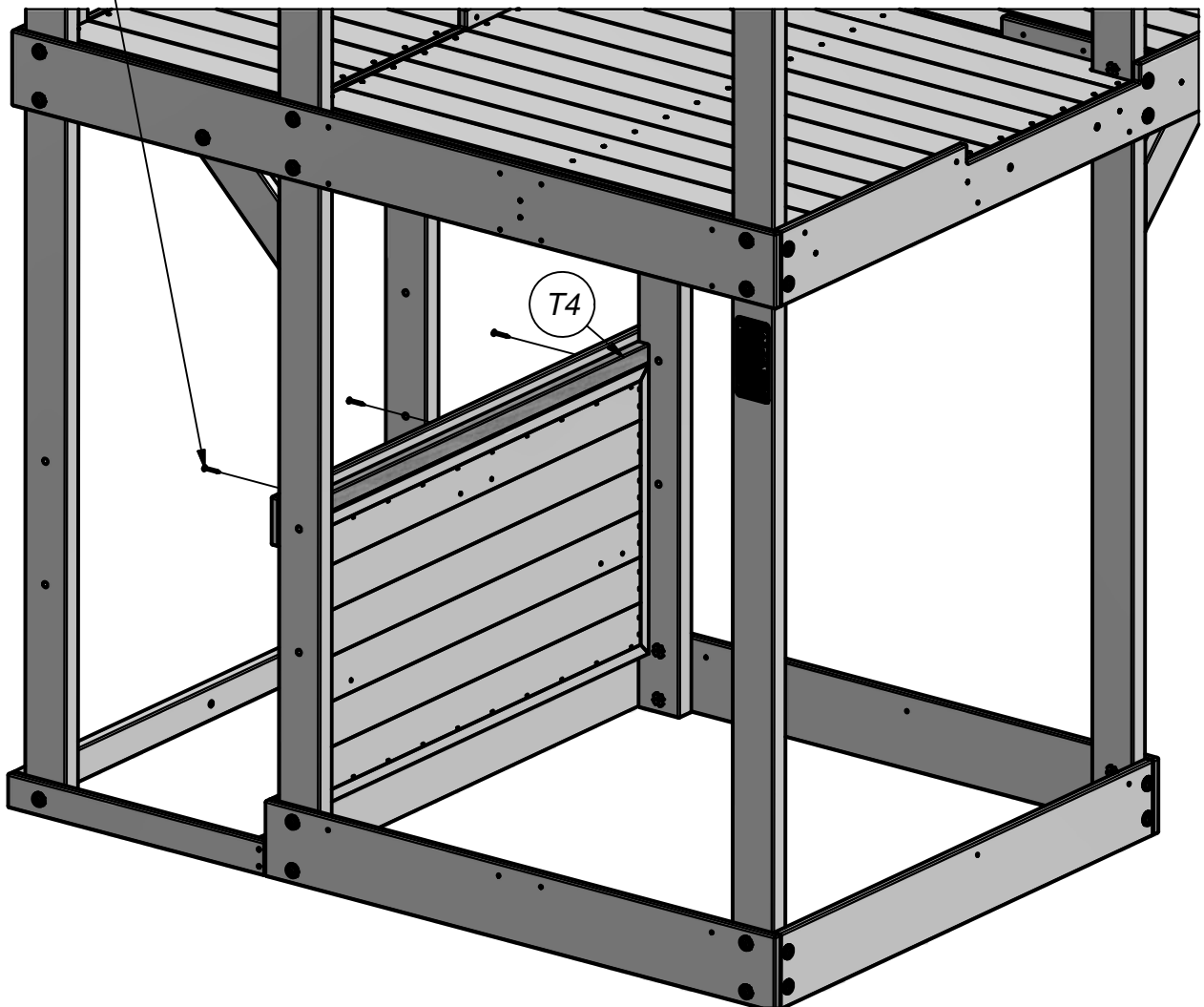



(2) **J6 - SUPPORT BLOCK - W4L07589**
1"x2 3/8"x6 1/4" (24x60x160)

STEP 20

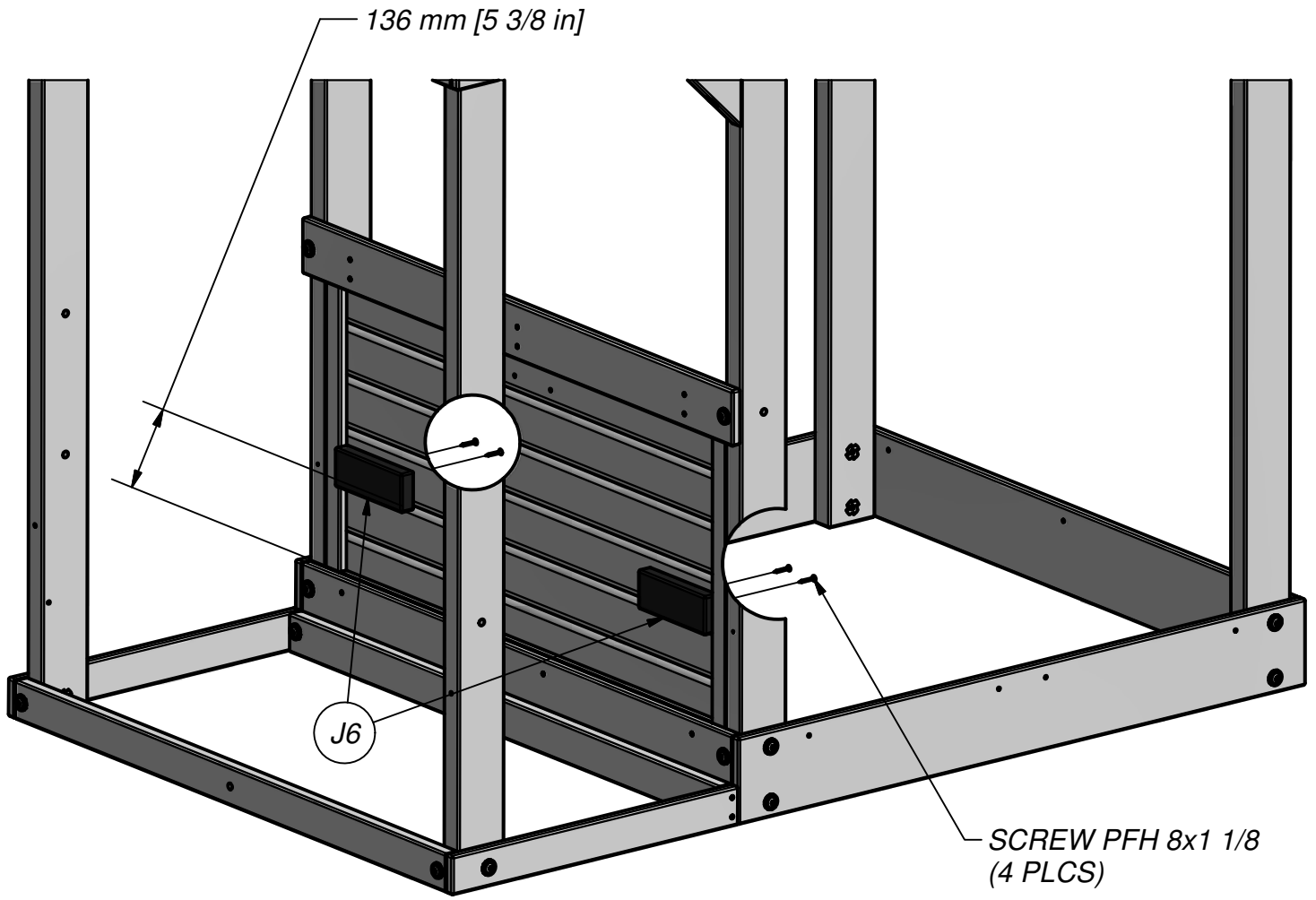
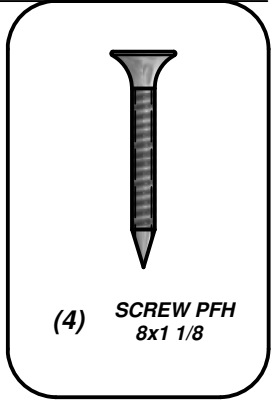



(1) **H1 - TABLE SUPPORT - W4L07583**
1"x3 3/8"x22 3/8" (24x86x567)



(1) **J7 - SUPPORT BLOCK - W4L07595**
1"x2 3/8"x3 3/8" (24x60x86)

STEP 21

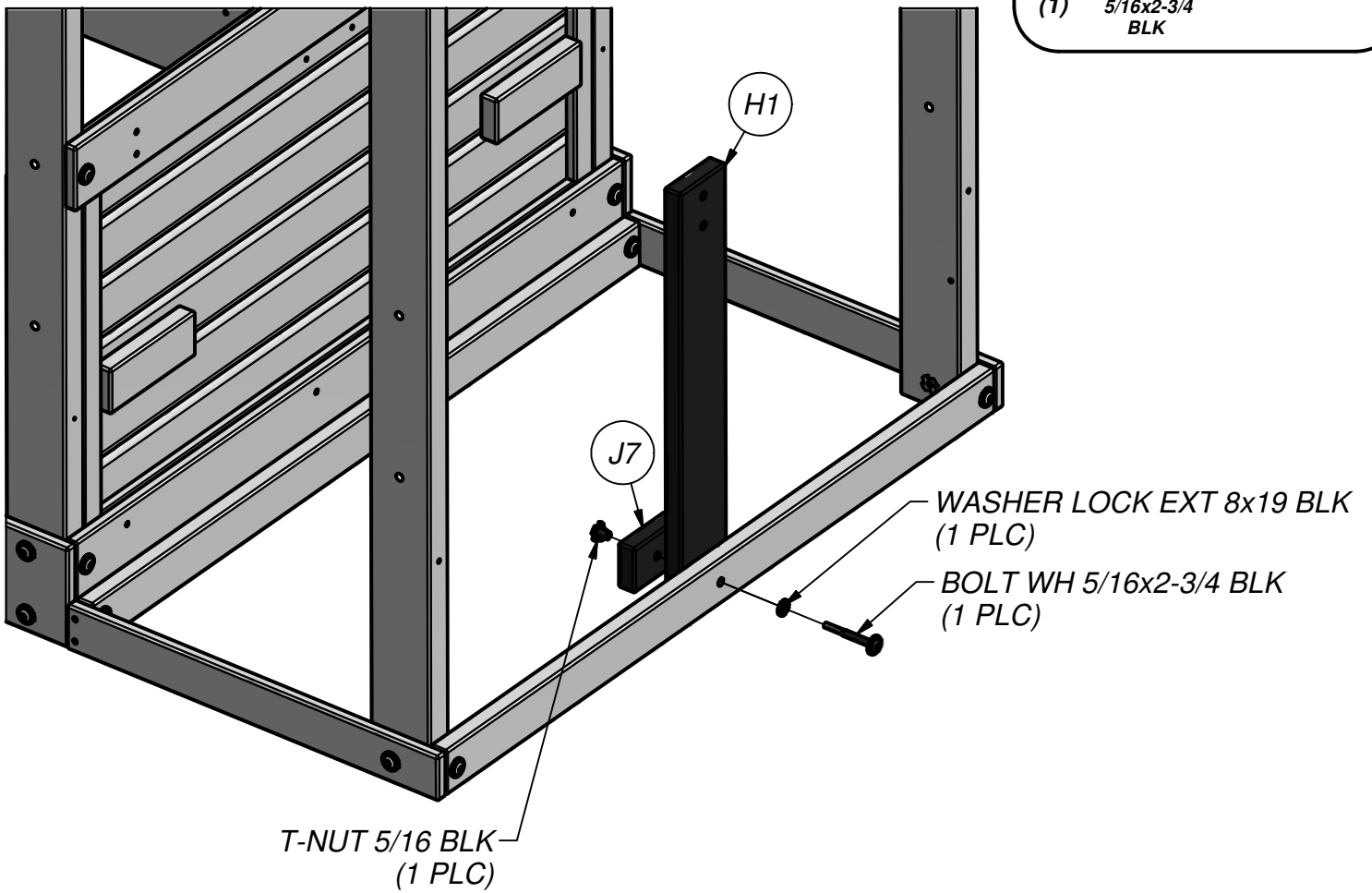
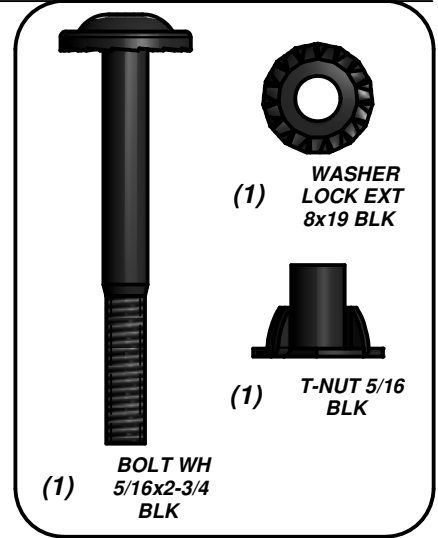



(8) **M4 - FLOOR BOARD - W4L07597**
5/8"x3 3/8"x21 1/8" (16x86x537)



(1) **M5 - FLOOR BOARD - W4L07598**
5/8"x3 3/8"x19 1/4" (16x86x488)



(2) **K17 - FLOOR BOARD - W4L07596**
5/8"x5 1/4"x21 1/8" (16x134x537)

STEP 22

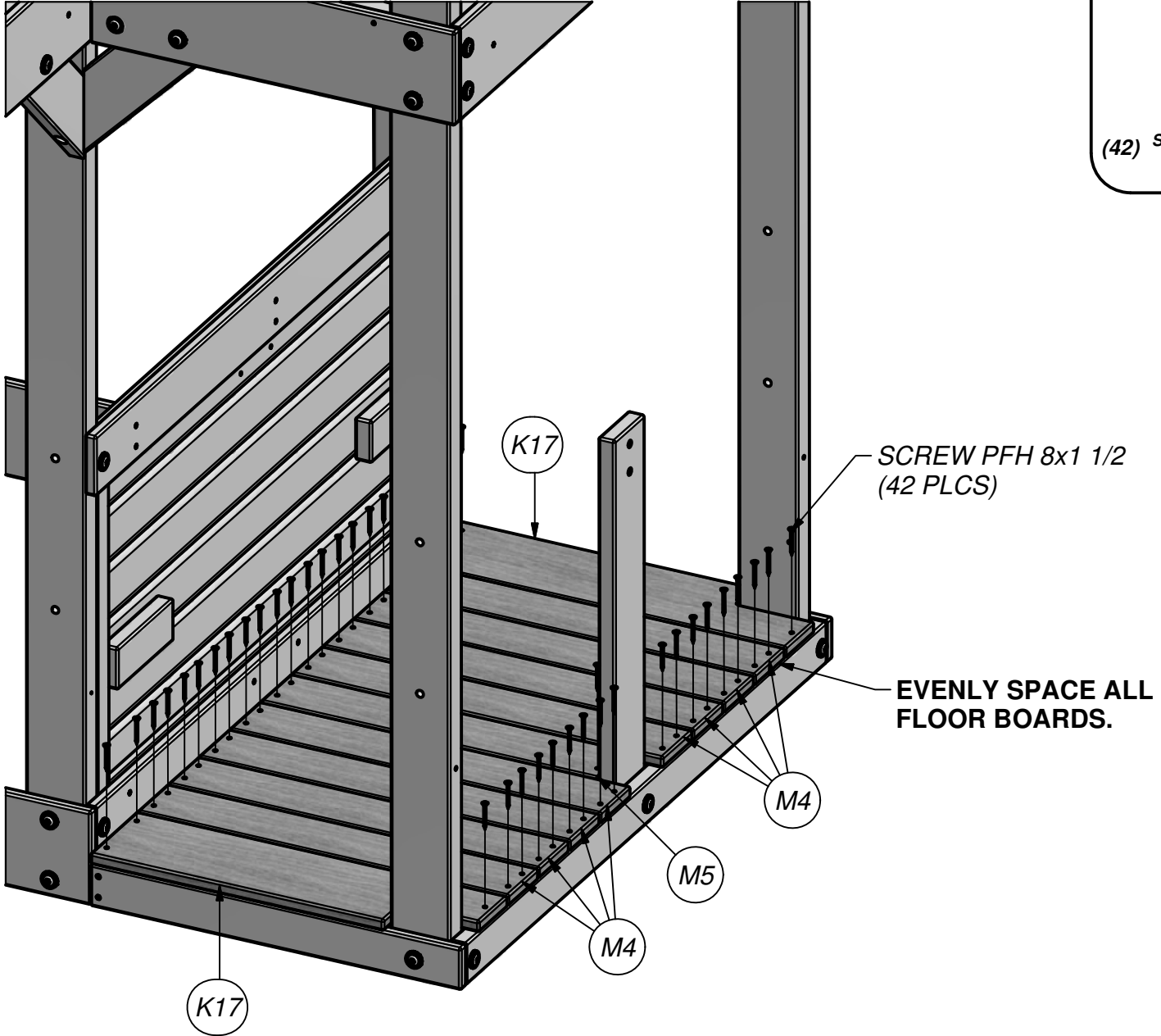
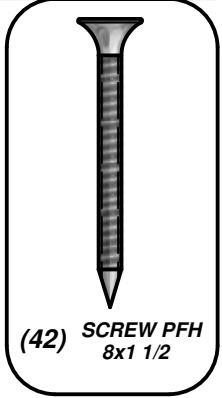



(2) **J3 - BENCH SUPPORT - W4L07586**
1"x2 3/8"x9" (24x60x230)

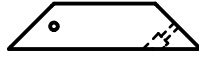

(2) **J4 - ANGLE BRACE - W4L07587**
1"x2 3/8"x10" (24x60x254)



(2) **J5 - SUPPORT BLOCK - W4L07588**
1"x2 3/8"x2 7/8" (24x60x72)

STEP 23

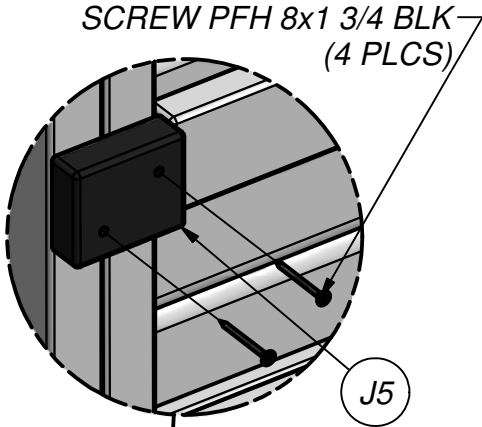

SCREW PFH 8x1 3/4 BLK
(4 PLCS)

J5

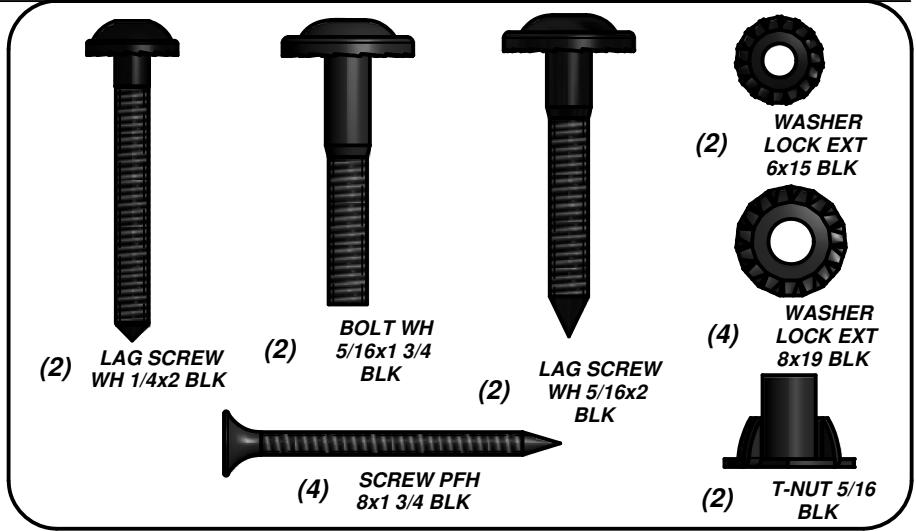

(2) LAG SCREW
WH 1/4x2 BLK

(2) BOLT WH
5/16x1 3/4
BLK

(2) LAG SCREW
WH 5/16x2
BLK

(4) SCREW PFH
8x1 3/4 BLK

(2) WASHER
LOCK EXT
6x15 BLK

(4) WASHER
LOCK EXT
8x19 BLK

(2) T-NUT 5/16
BLK

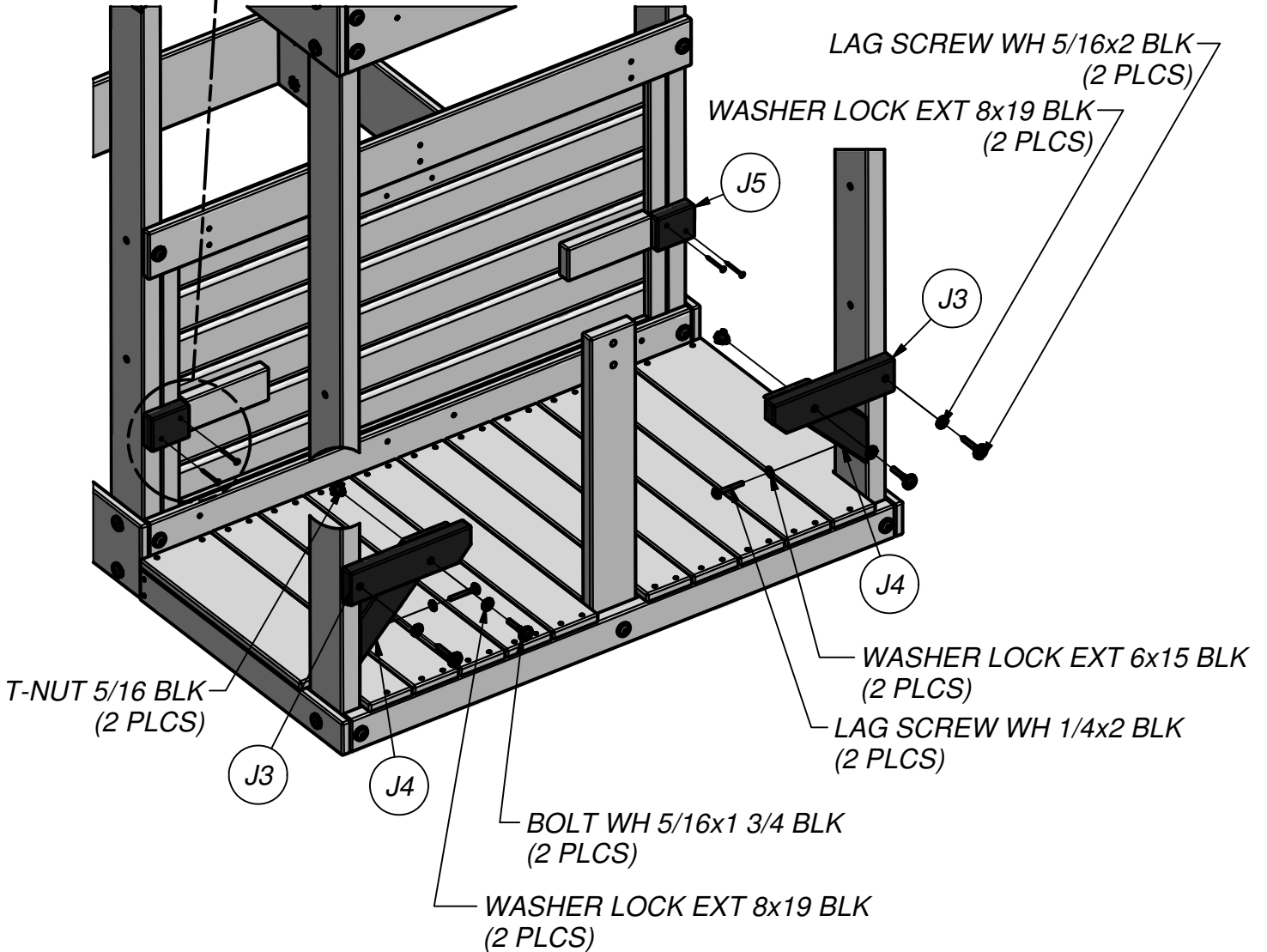

T-NUT 5/16 BLK
(2 PLCS)

J3

J4

BOLT WH 5/16x1 3/4 BLK
(2 PLCS)

WASHER LOCK EXT 8x19 BLK
(2 PLCS)

LAG SCREW WH 5/16x2 BLK
(2 PLCS)

WASHER LOCK EXT 8x19 BLK
(2 PLCS)

J5

J3

J4

WASHER LOCK EXT 6x15 BLK
(2 PLCS)

LAG SCREW WH 1/4x2 BLK
(2 PLCS)

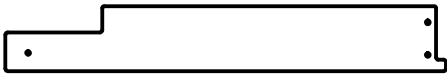

(2) **M2 - BENCH BOARD - W4L07591**
5/8"x3 3/8"x23" (16x86x583)

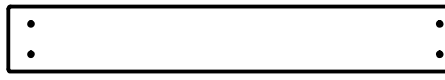

(2) **M3 - TABLE BOARD - W4L07593**
5/8"x3 3/8"x23" (16x86x583)

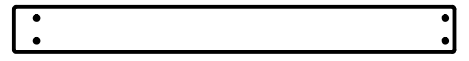

(2) **N3 - BENCH BOARD - W4L07592**
5/8"x2 3/8"x23" (16x60x583)

STEP 24

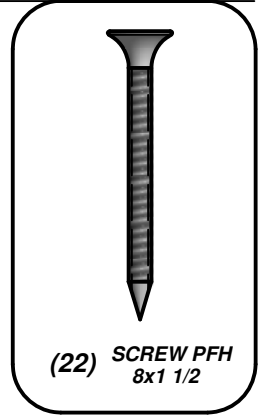
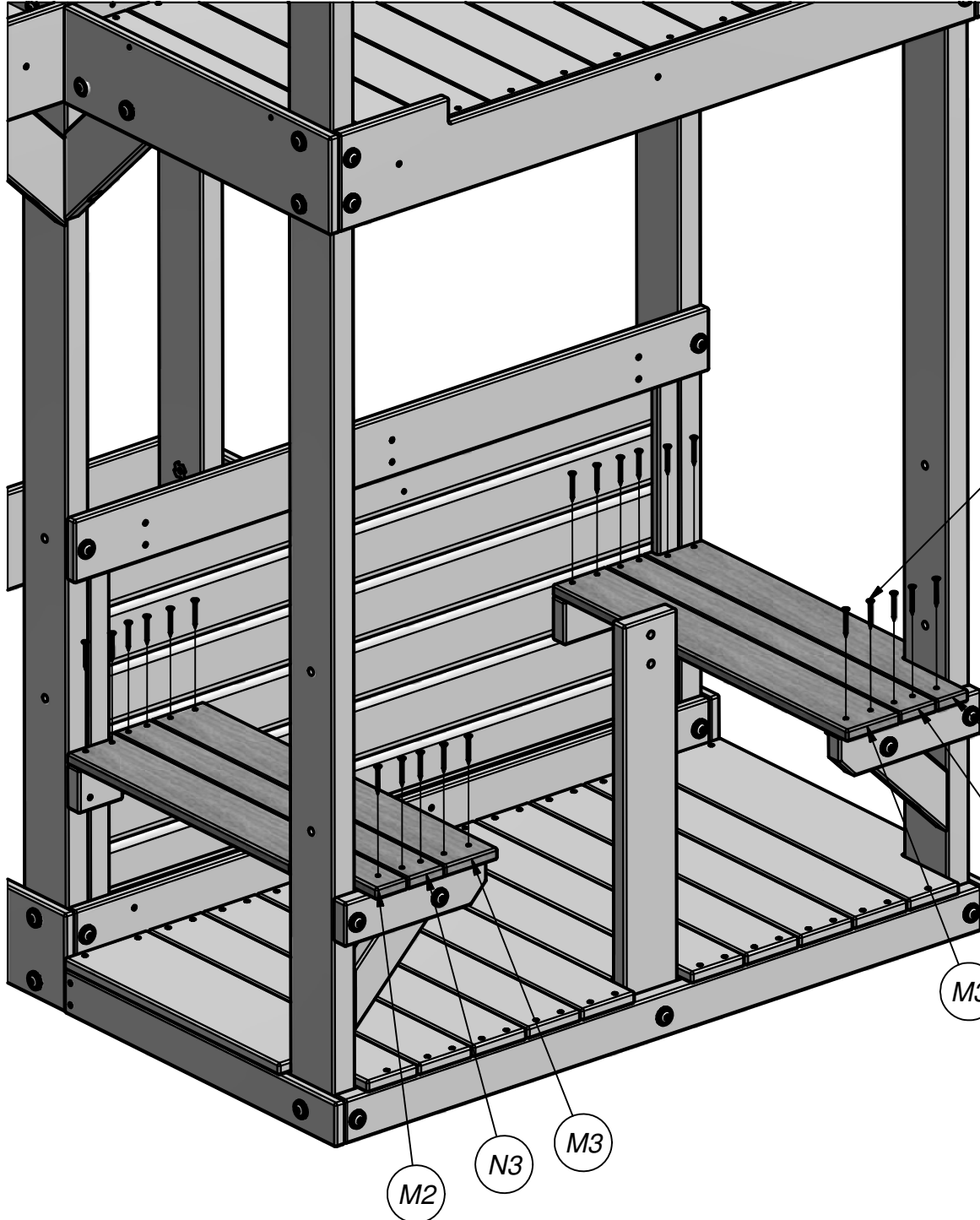

SCREW PFH 8x1 1/2
(22 PLCS)

M2

N3

M3

M2

N3

M3



(1) **K16 - TABLE BOARD - W4L07594**
5/8"x5 1/4"x23" (16x134x583)



(2) **M3 - TABLE BOARD - W4L07593**
5/8"x3 3/8"x23" (16x86x583)

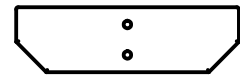

(1) **H2 - TABLE SUPPORT - W4L07584**
1"x3 3/8"x11 5/8" (24x86x295)



(1) **H3 - TABLE SUPPORT - W4L07585**
1"x3 3/8"x11 5/8" (24x86x295)

STEP 25

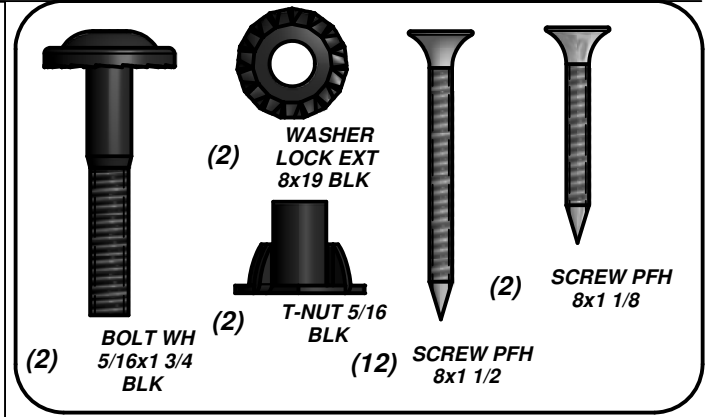
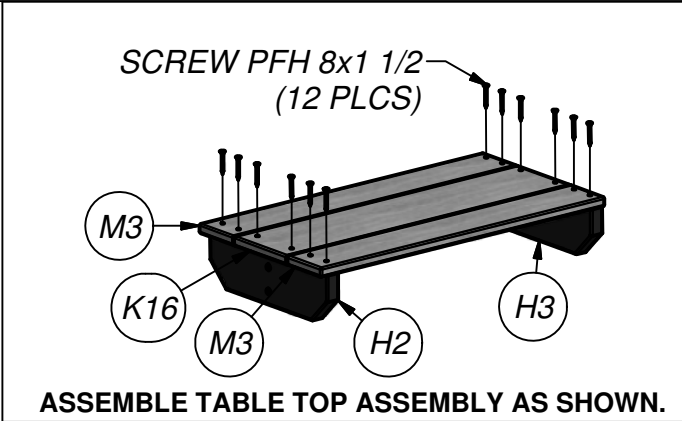

INSTALL T-NUTS INTO PARTS BEFORE ASSEMBLY OF PARTS.

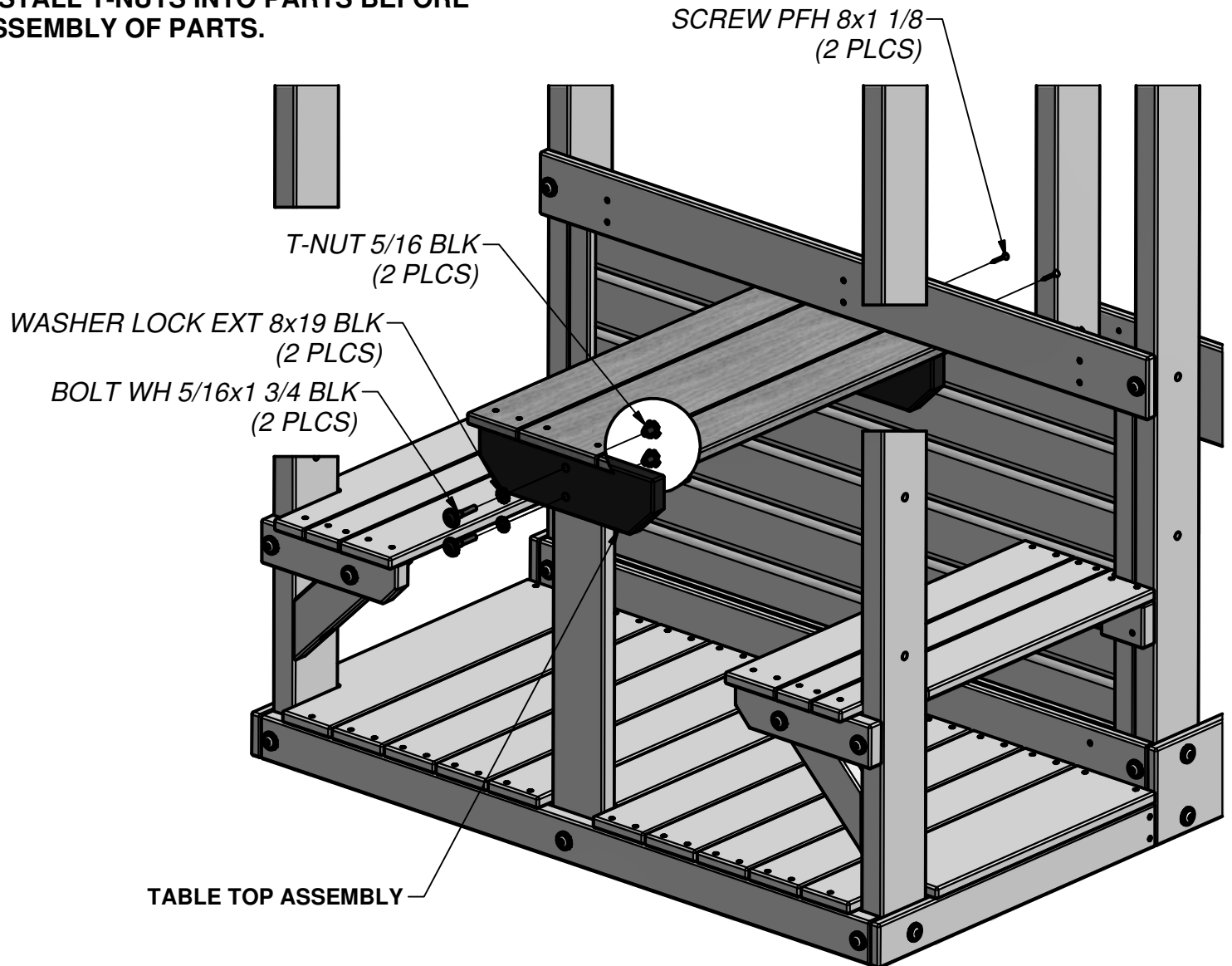

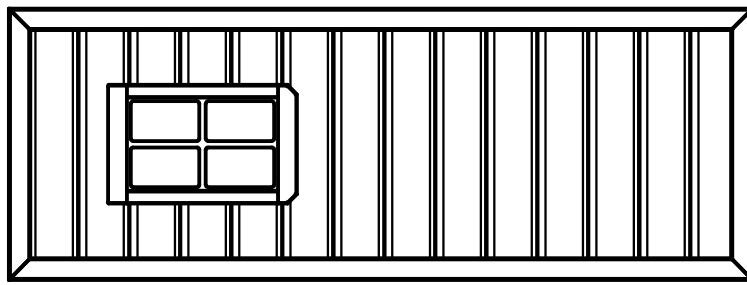

(2) WP2 - RIGHT LOWER WALL PANEL - W2A02083
 1"x16 7/8"x46 1/2" (24x430x1181)

STEP 26

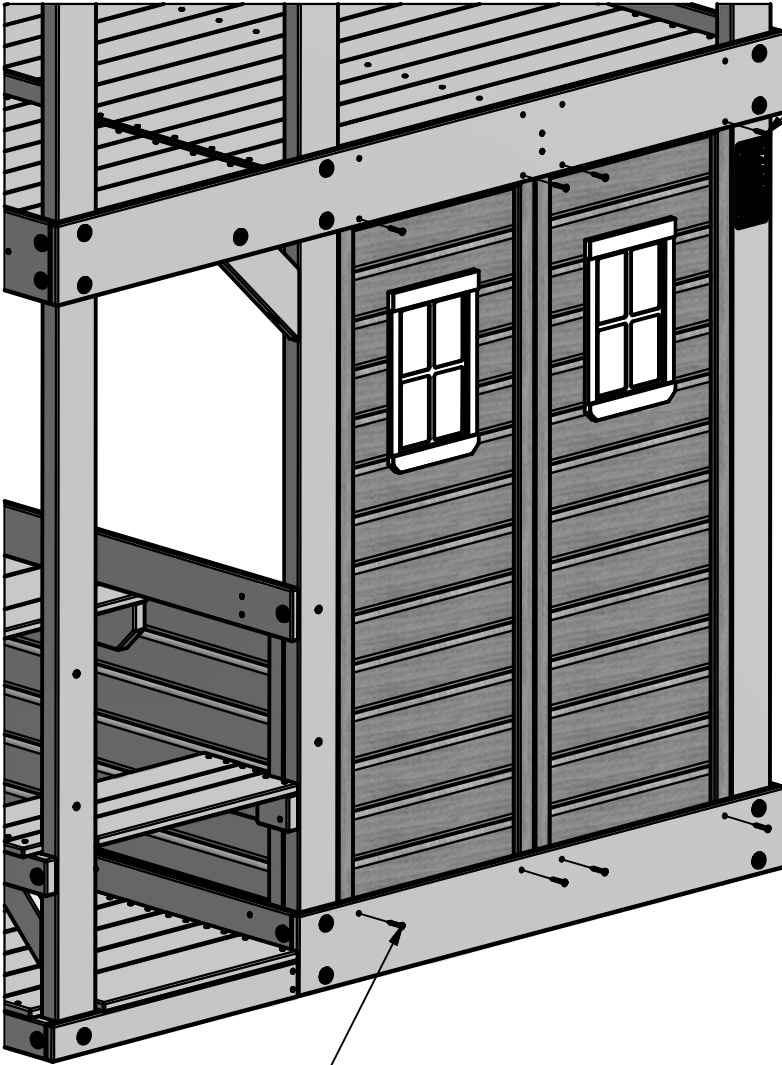

SCREW PFH 8x1 1/4 BLK
 (4 PLCS)

SCREW PFH 8x1 1/4 BLK
 (4 PLCS)

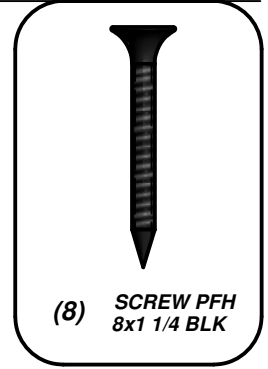

(8) SCREW PFH
 8x1 1/4 BLK

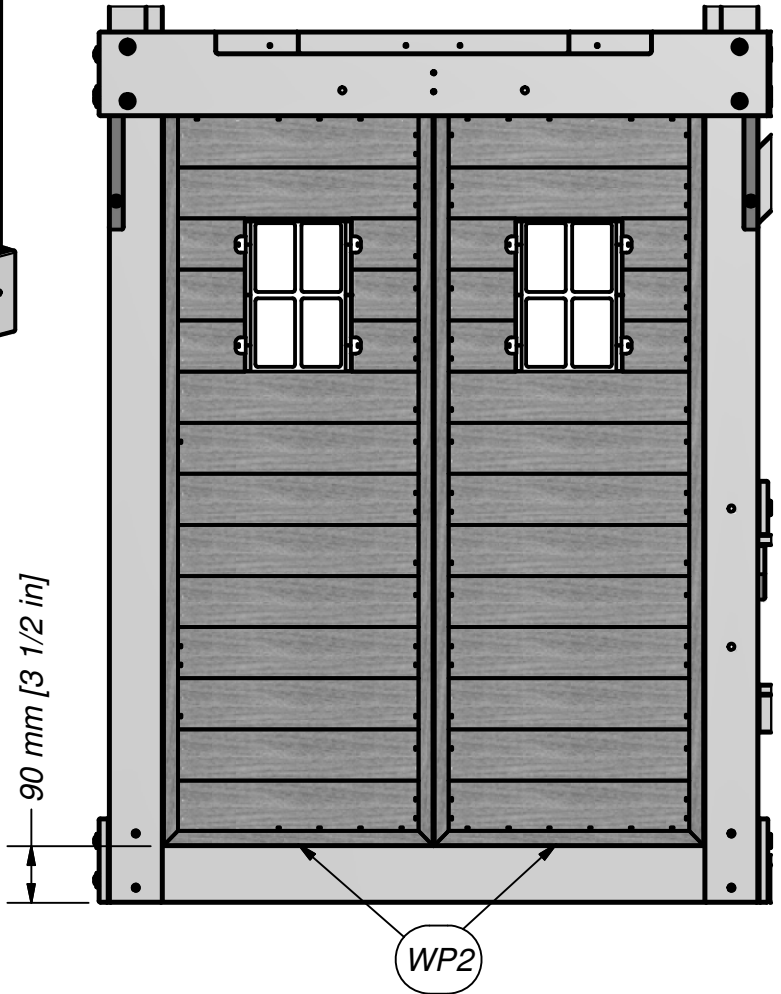

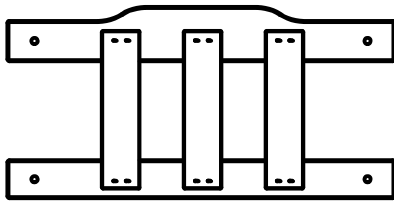

(1) **WP10 - BENCH BACK ASSEMBLY - W2A02081**
 1 1/8"x11 7/8"x17 5/8" (27x303x615)

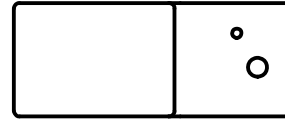

(1) **F3 - SUPPORT BLOCK - W4L07604**
 1 3/8"x2 3/8"x5 7/8" (36x60x148)

STEP 27

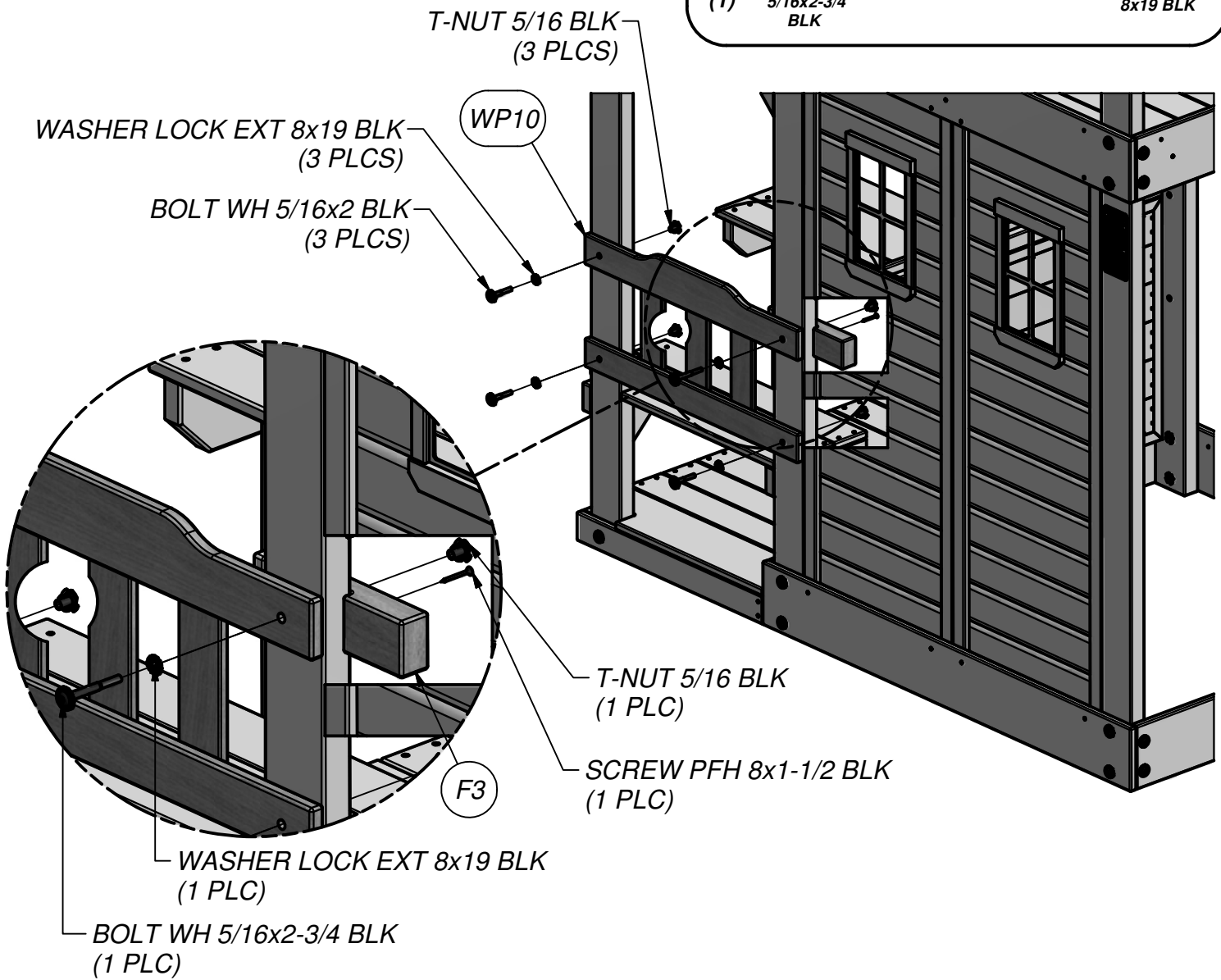
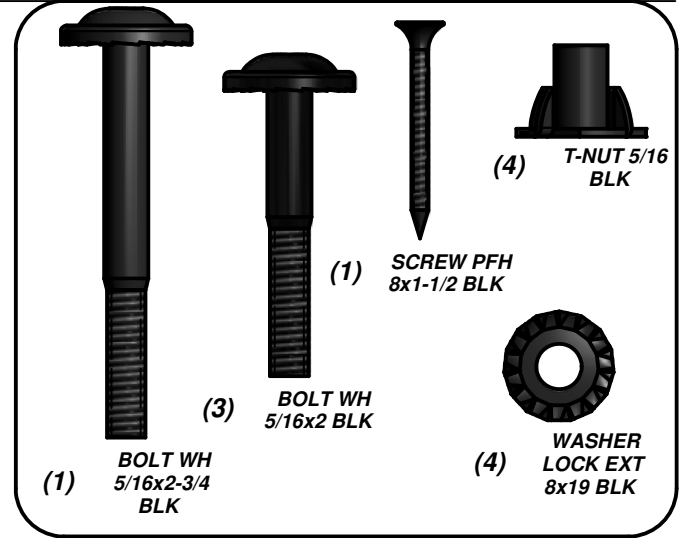

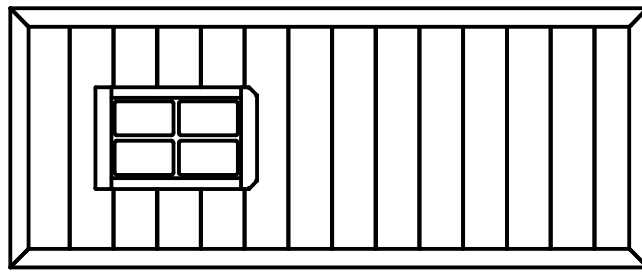

(1) WP9 - LOWER WALL PANEL - W2A02090
1"x16 7/8"x46 1/2" (24x476x1181)

STEP 28

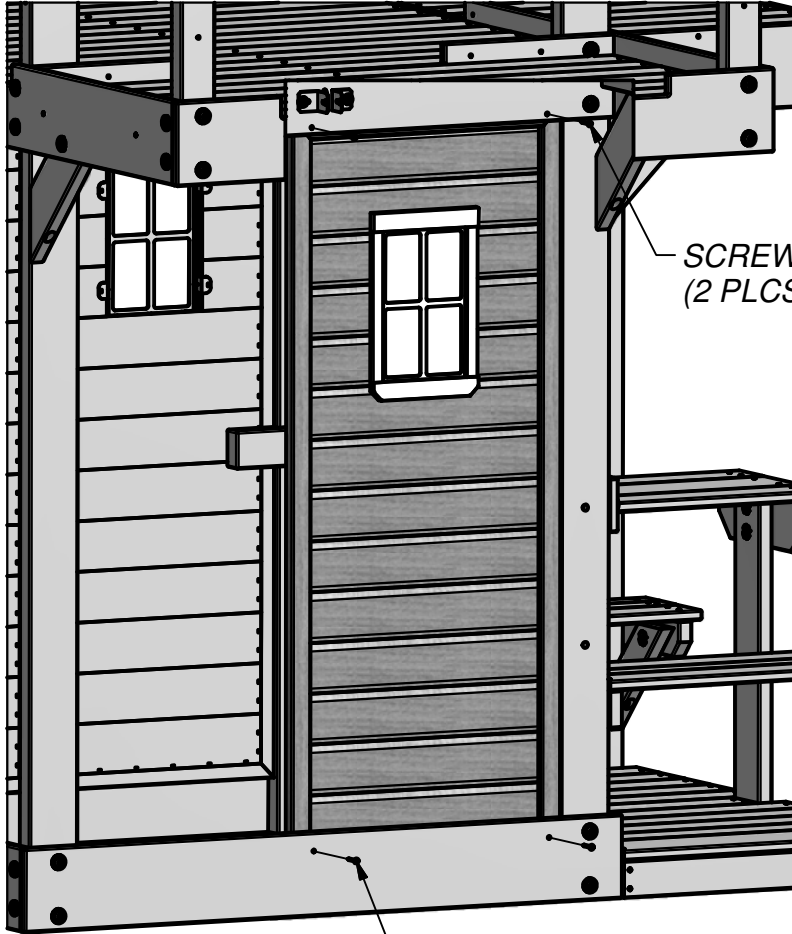

SCREW PFH 8x1 1/4 BLK
(2 PLCS)

SCREW PFH 8x1 1/4 BLK
(2 PLCS)

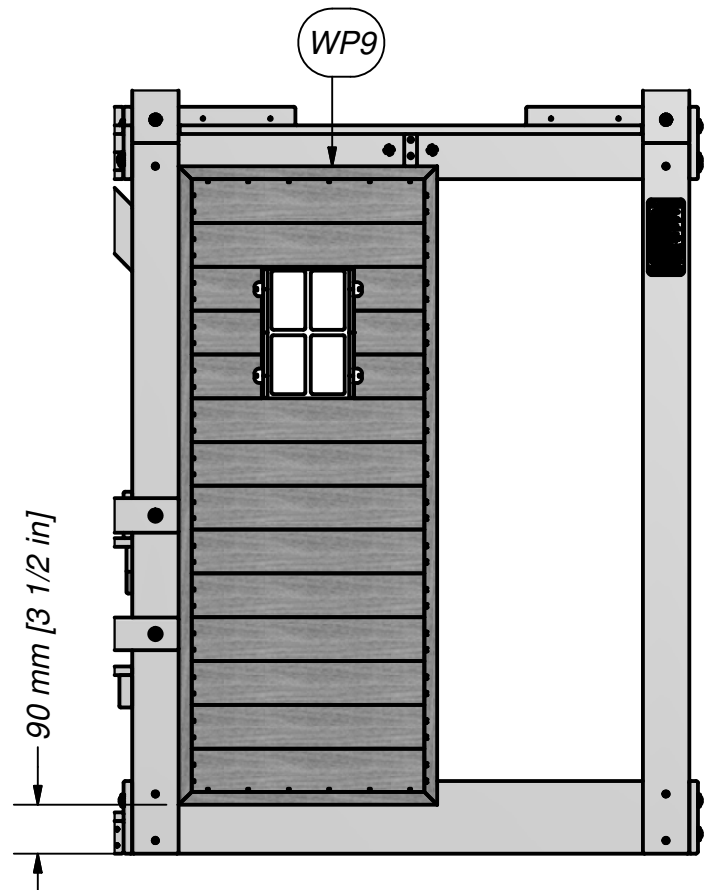
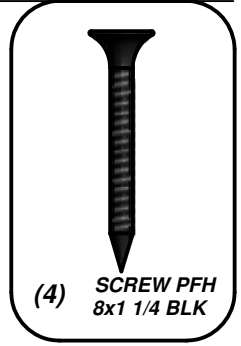

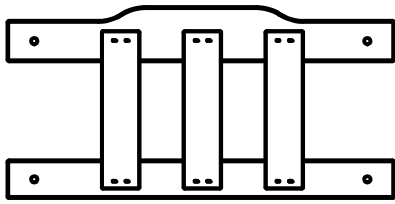

(1) WP10 - BENCH BACK ASSEMBLY - W2A02081
1 1/8"x11 7/8"x17 5/8" (27x303x615)

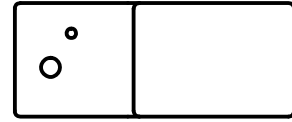

(1) F4 - SUPPORT BLOCK - W4L07614
1 3/8"x2 3/8"x5 7/8" (36x60x148)

STEP 29

T-NUT 5/16 BLK
(3 PLCS)

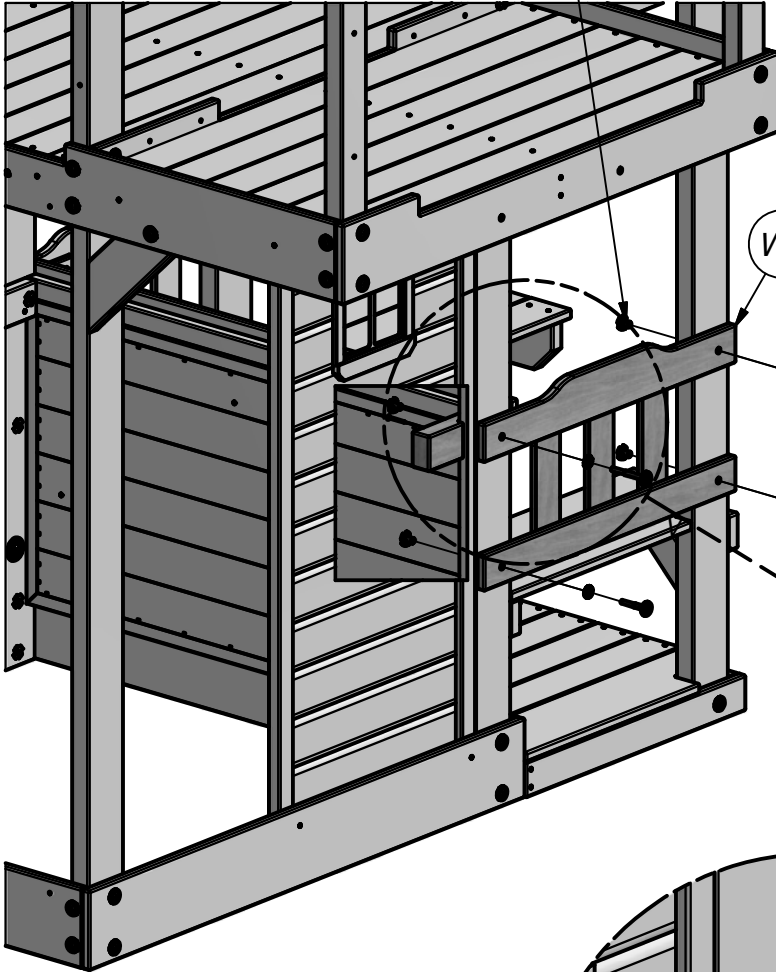

WP10

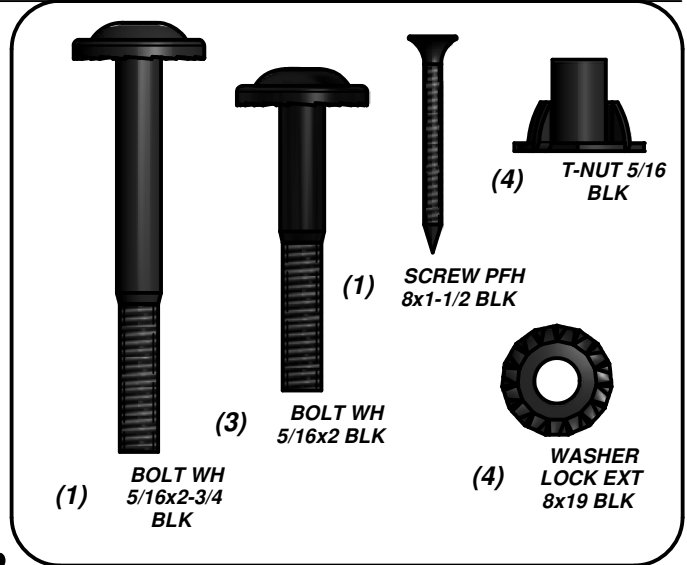

BOLT WH 5/16x2 BLK
(3 PLCS)

WASHER LOCK EXT 8x19 BLK
(3 PLCS)

T-NUT 5/16 BLK
(1 PLC)

SCREW PFH 8x1-1/2 BLK
(1 PLC)

F4

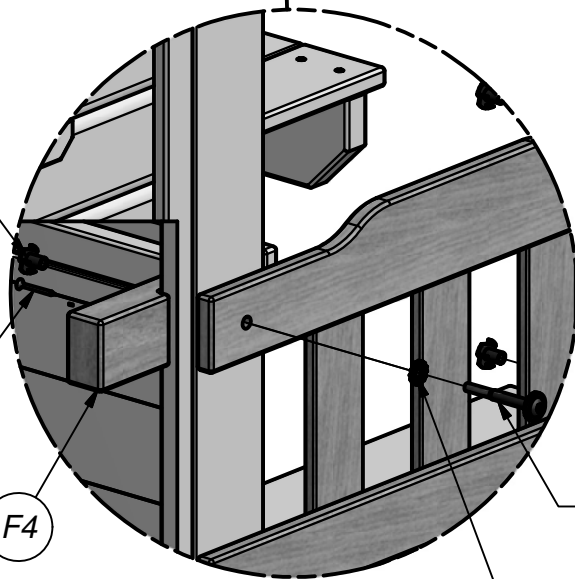

BOLT WH 5/16x2-3/4 BLK
(1 PLC)

WASHER LOCK EXT 8x19 BLK
(1 PLC)



(1) **M6 - COUNTER TOP - W4L07605**
5/8"x3 3/8"x37 5/8" (16x86x957)



(1) **M7 - COUNTER TOP - W4L07606**
5/8"x3 3/8"x38 5/8" (16x86x981)

STEP 30

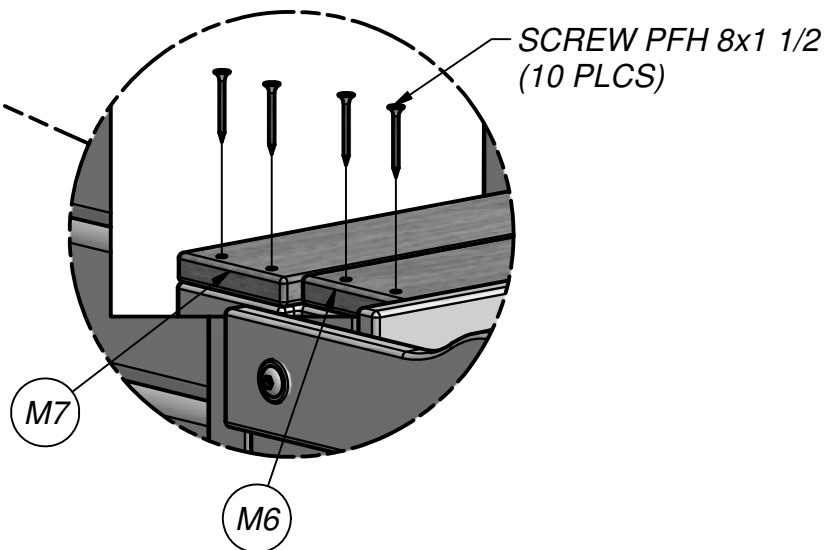
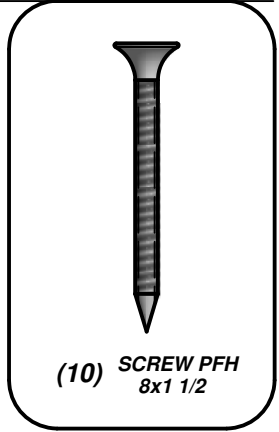
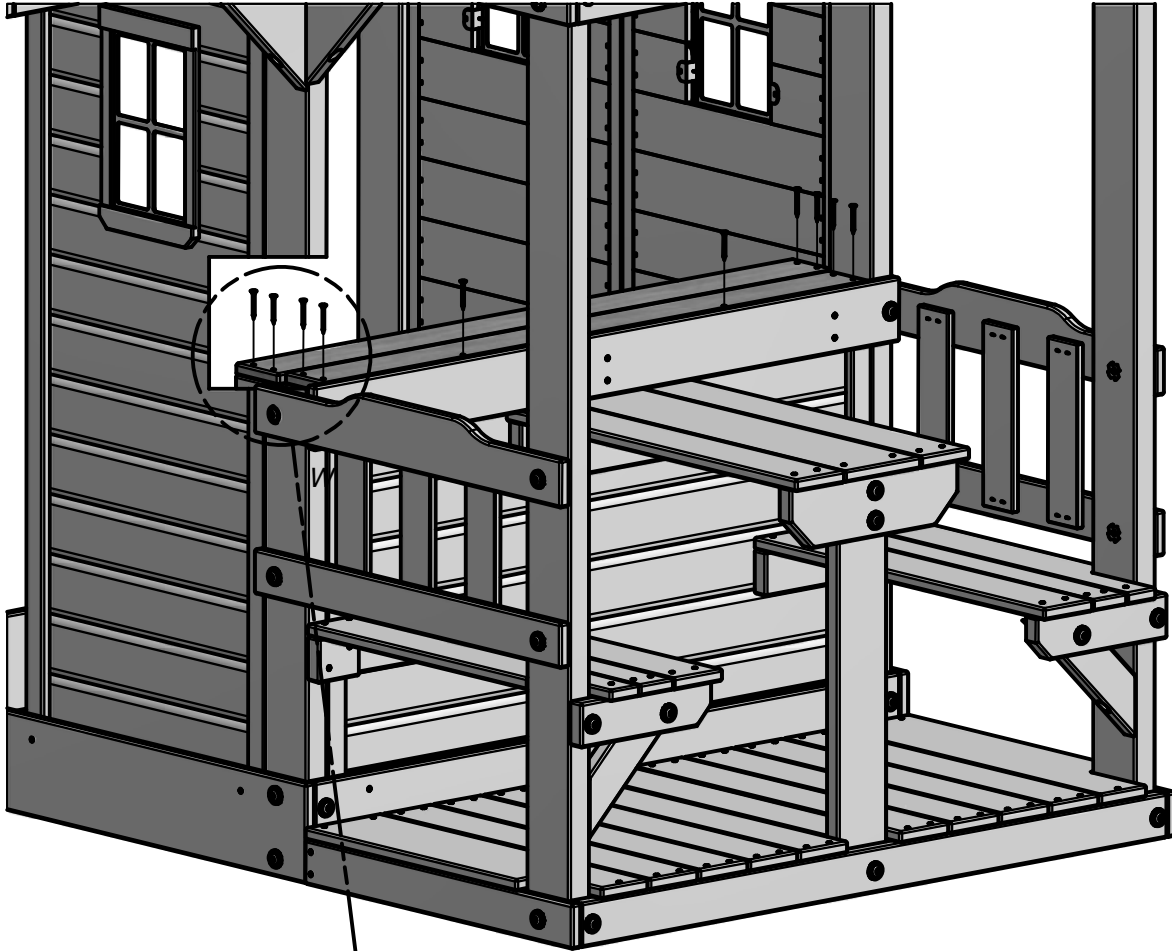

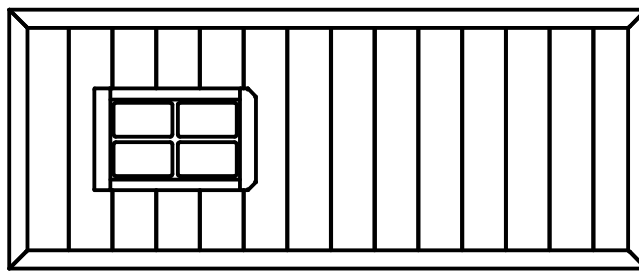

(1) WP9 - LOWER WALL PANEL - W2A02090
1"x16 7/8"x46 1/2" (24x476x1181)

STEP 31

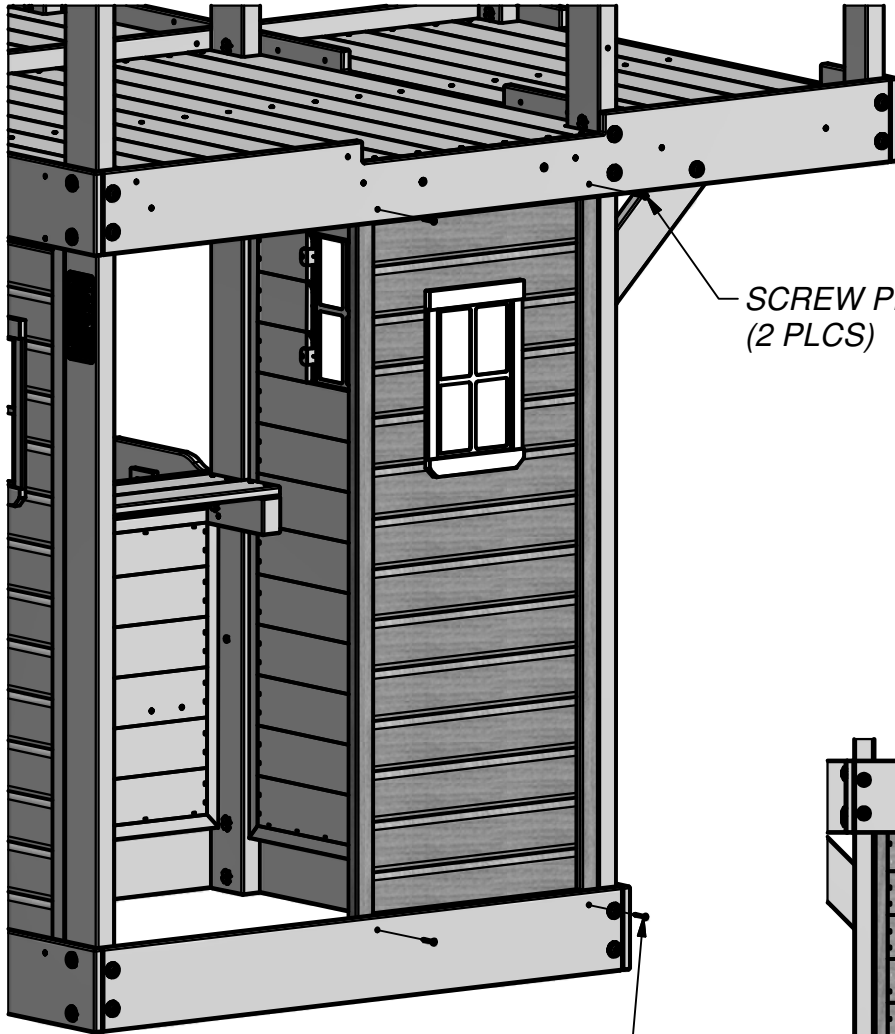

SCREW PFH 8x1 1/4 BLK
(2 PLCS)

SCREW PFH 8x1 1/4 BLK
(2 PLCS)

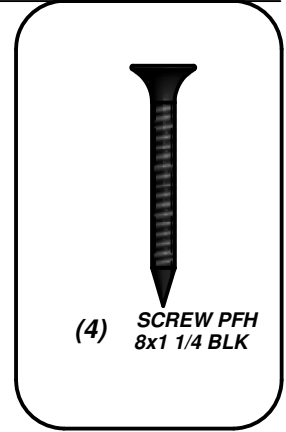

(4) SCREW PFH
8x1 1/4 BLK

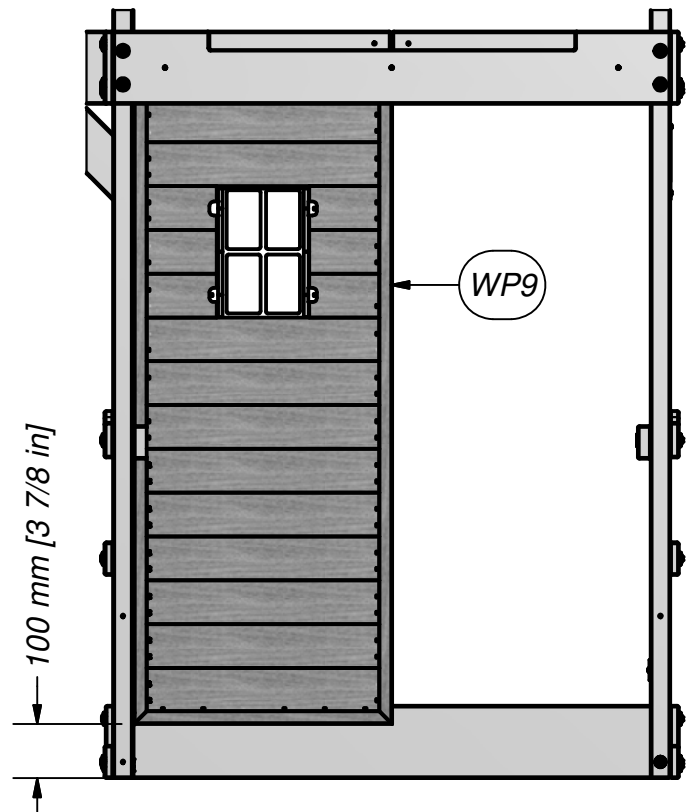

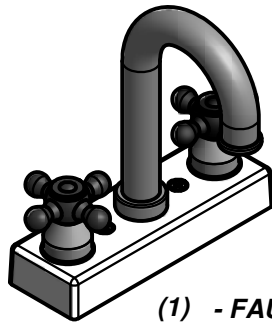

(1) - FAUCET KIT - A6P00024

STEP 32

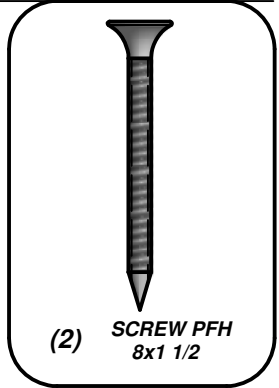
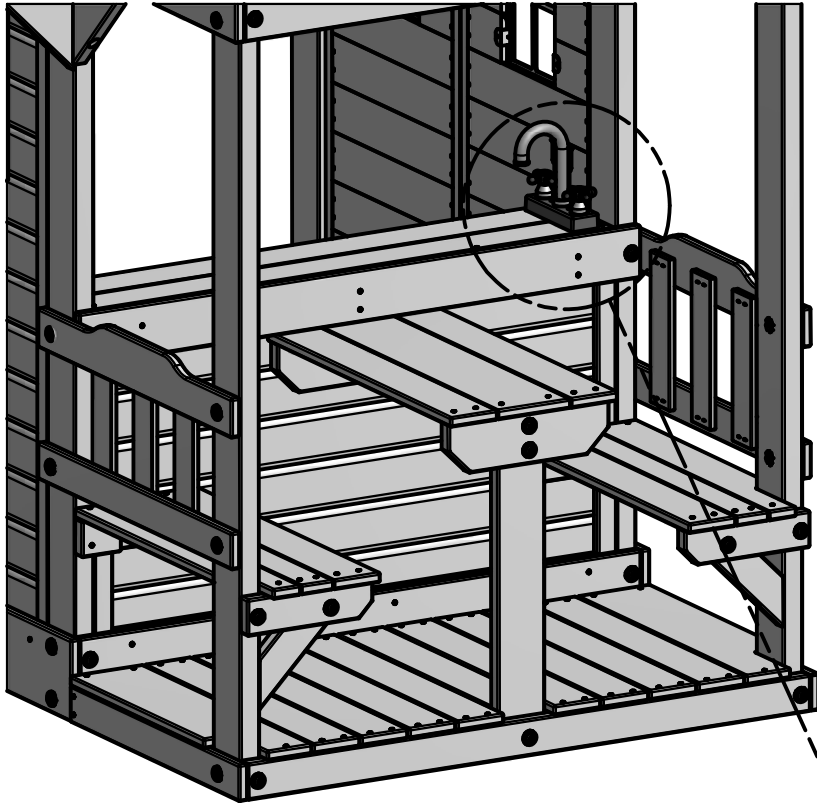

(2) SCREW PFH
8x1 1/2

SCREW PFH 8x1 1/2
(2 PLCS)

FAUCET KIT

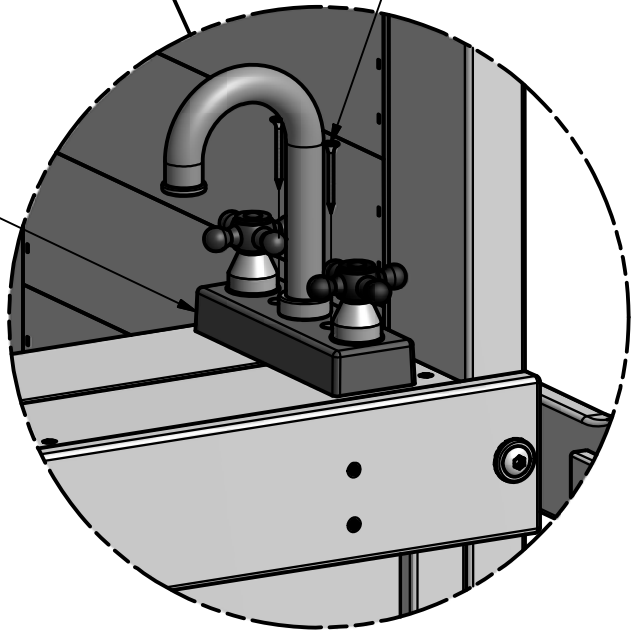

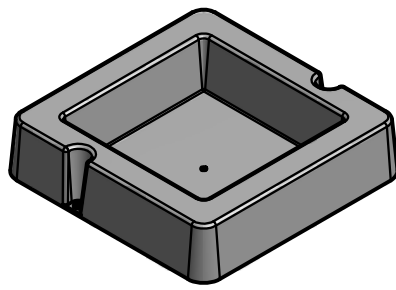

(1) - SURFACE MOUNT BASIN - A6P00032

STEP 33

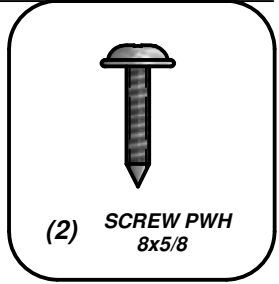
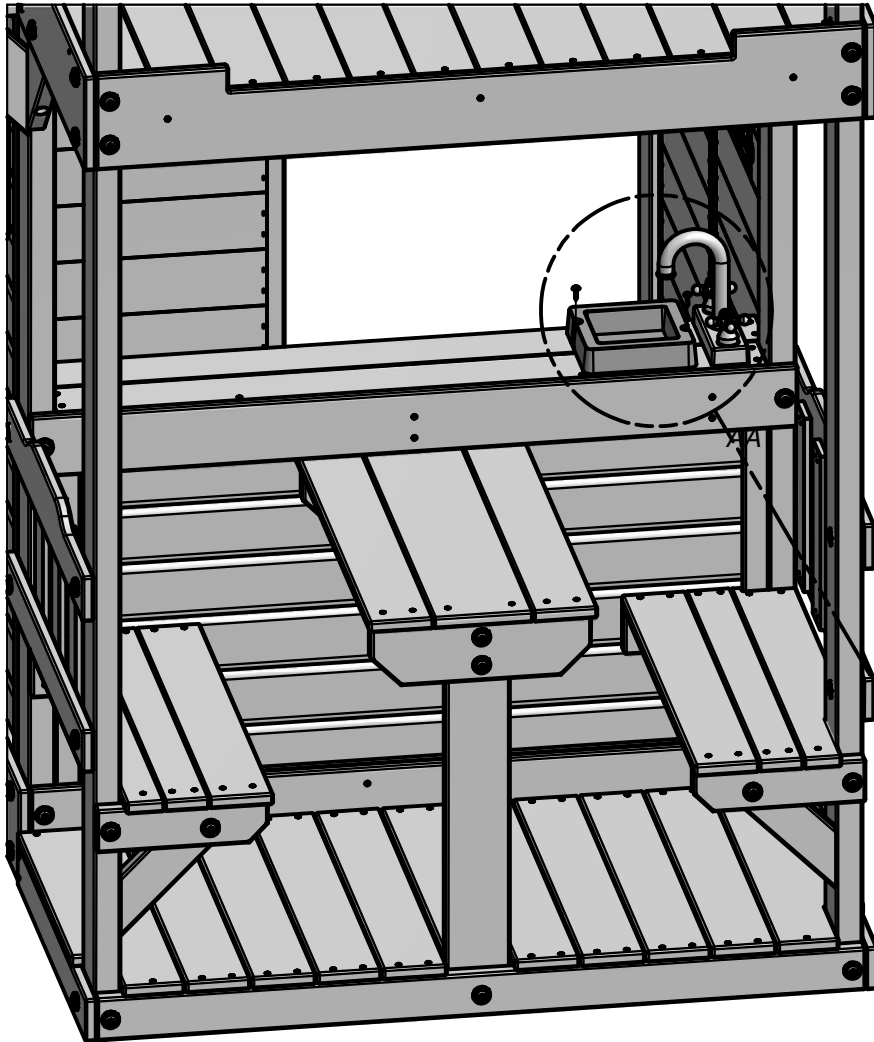

SCREW PWH 8x5/8
(2 PLCS)

SURFACE MOUNT BASIN

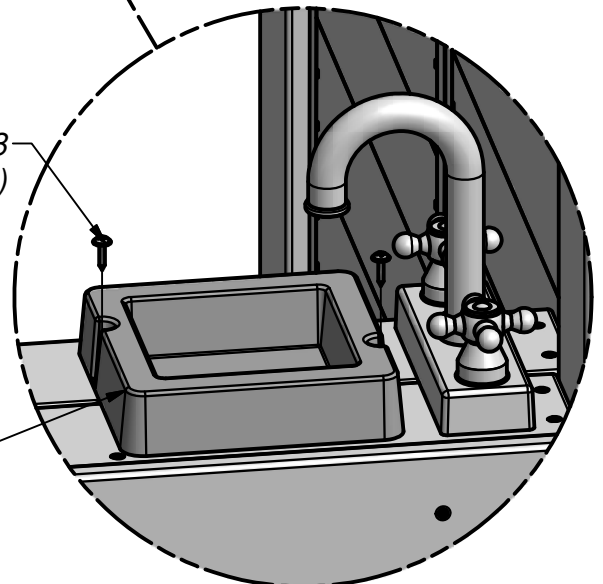

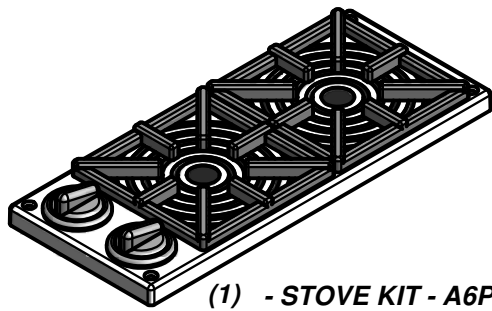

(1) - STOVE KIT - A6P00025

STEP 34

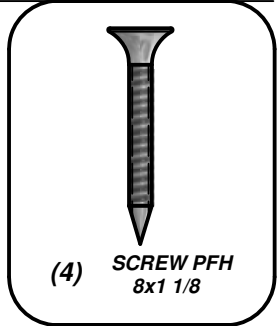
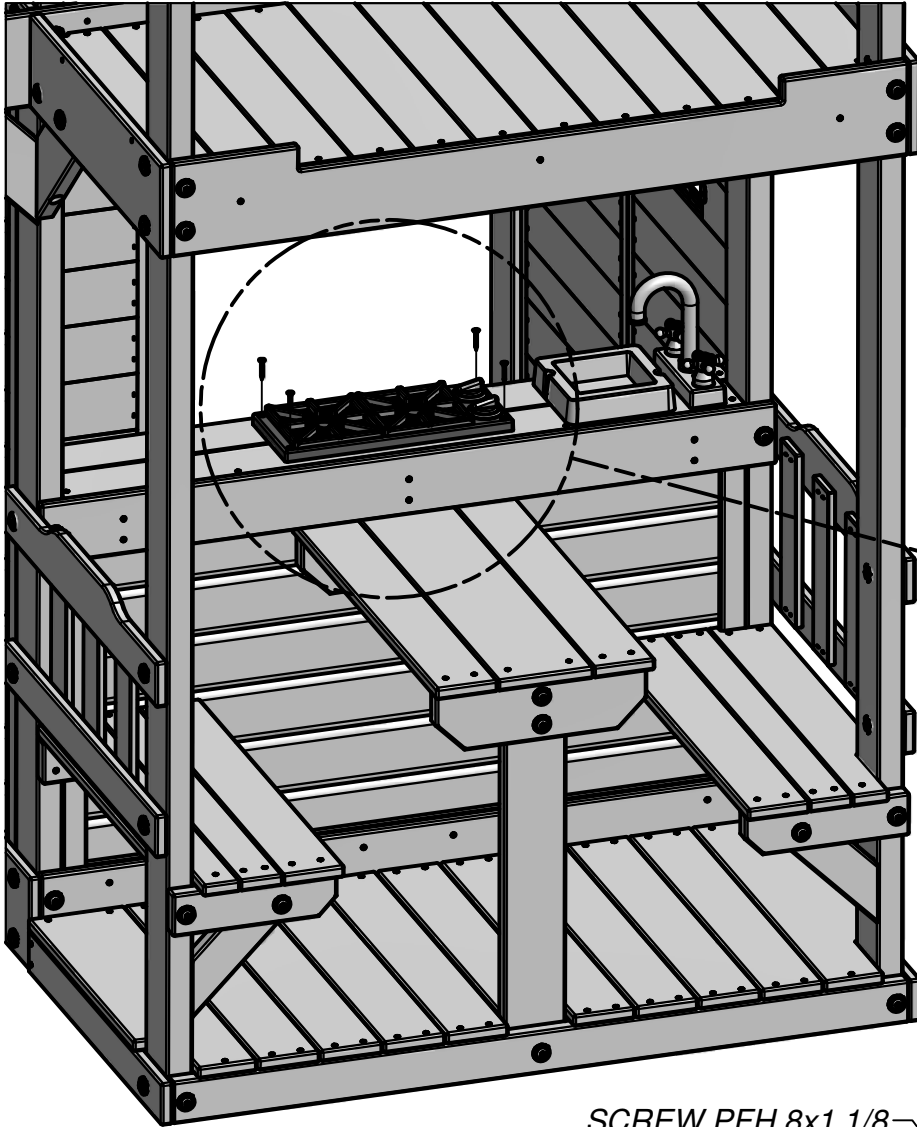

(4) SCREW PFH
8x1 1/8

SCREW PFH 8x1 1/8
(4 PLCS)

STOVE KIT

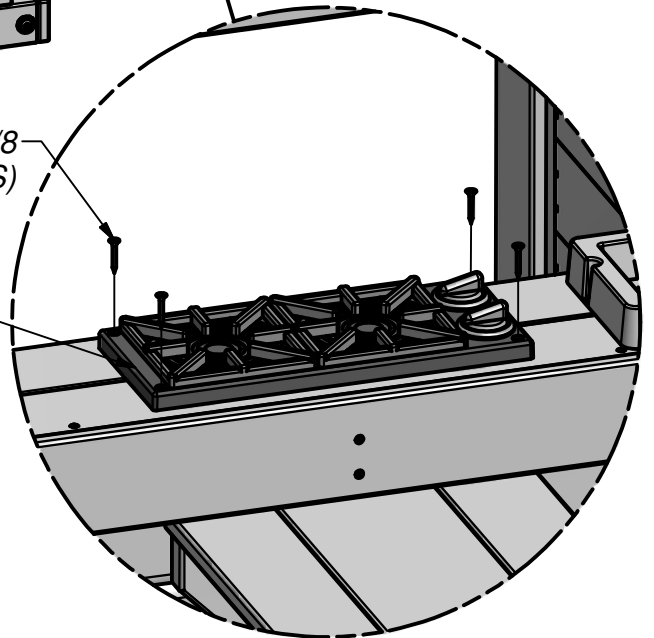

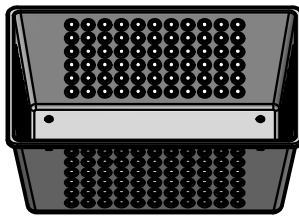

(1) FRUIT BASKET KIT - A6P00069

STEP 35

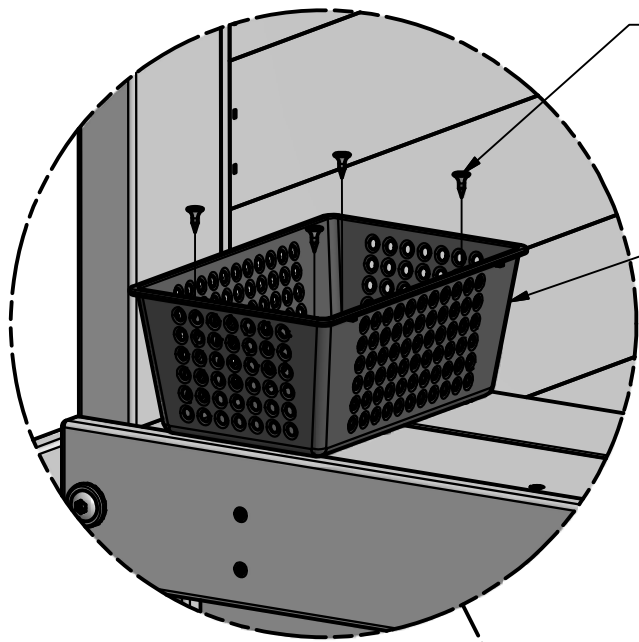

SCREW PFH 8x1/2
(4 PLCS)

FRUIT BASKET KIT



(4) SCREW PFH
8x1/2

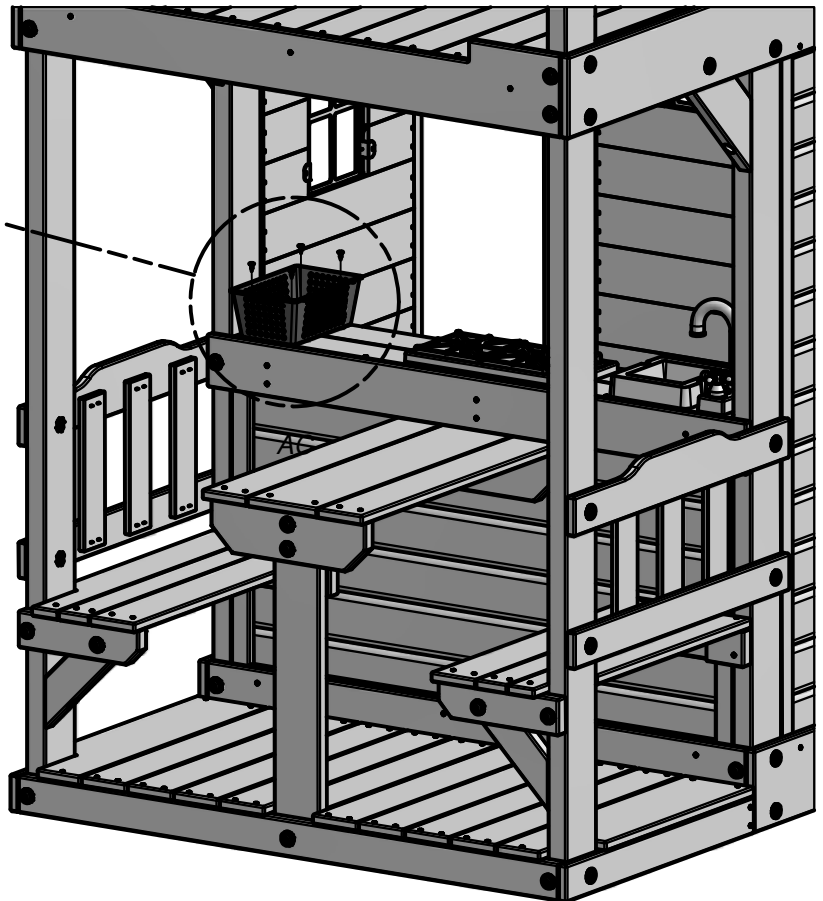

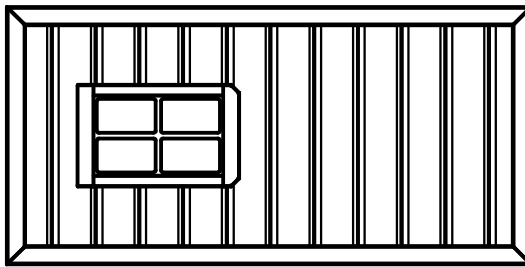

(1) WP7 - TOP FRONT WALL PANEL - W2A02088
1"x16 7/8"x38 1/4" (24x476x971)

STEP 36

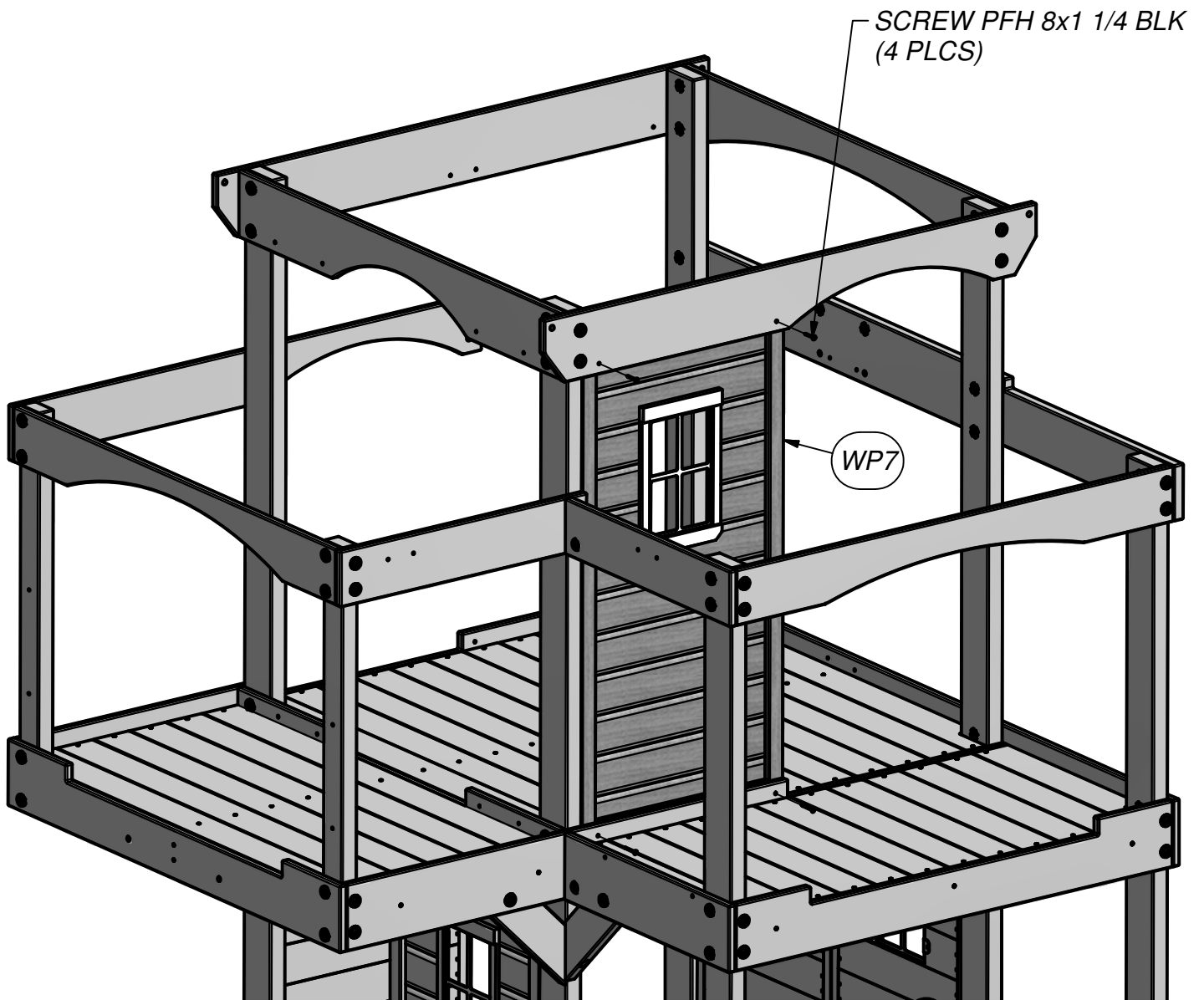
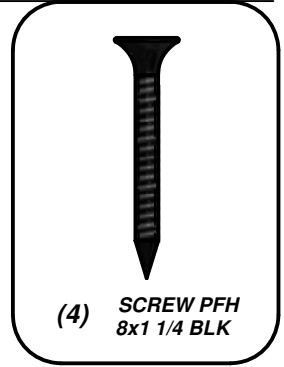

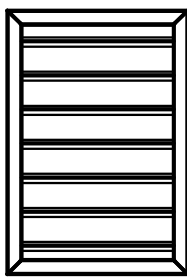

(2) WP3 - TOP RIGHT FRONT WALL PANEL - W2A02084
1"x16 7/8"x24 5/8" (24x430x627)

STEP 37

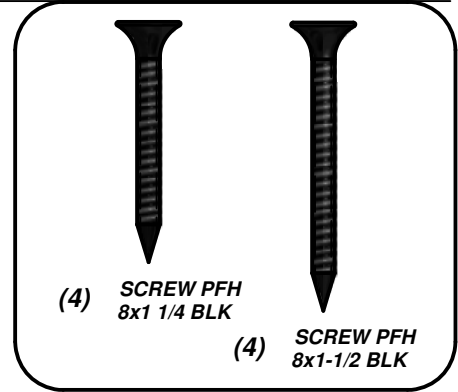
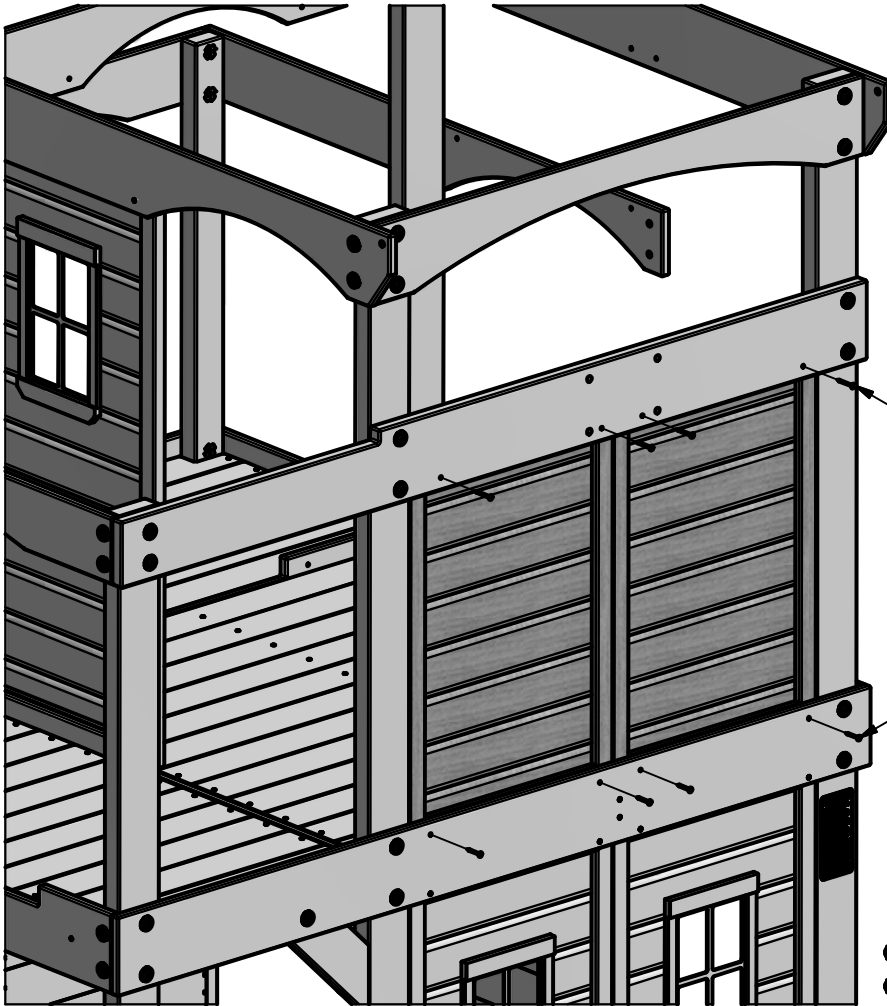

SCREW PFH 8x1-1/2 BLK
(4 PLCS)

SCREW PFH 8x1 1/4 BLK
(4 PLCS)

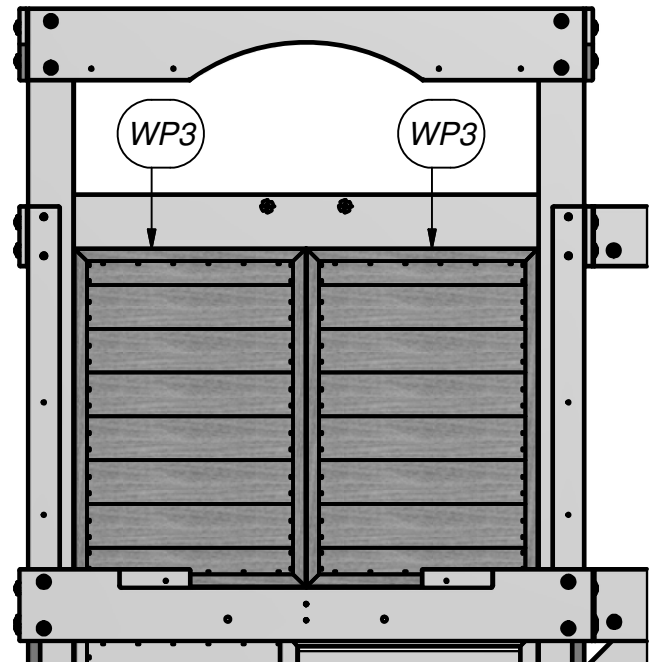

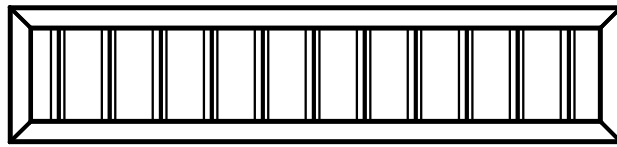

(2) WP8 - TOP LEFT WALL PANEL - W2A02089
1"x11 3/4"x38 1/4" (24x214x971)

STEP 38

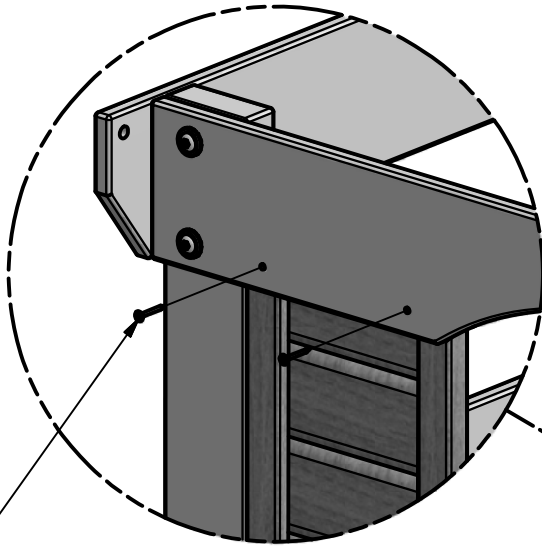
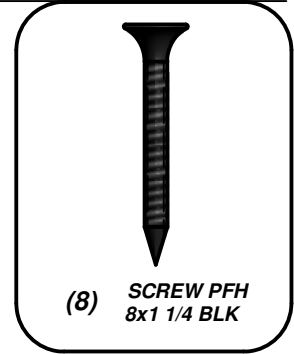

— SCREW PFH 8x1 1/4 BLK
(4 PLCS)

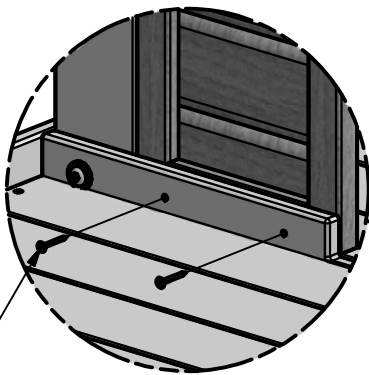

— SCREW PFH 8x1 1/4 BLK
(4 PLCS)

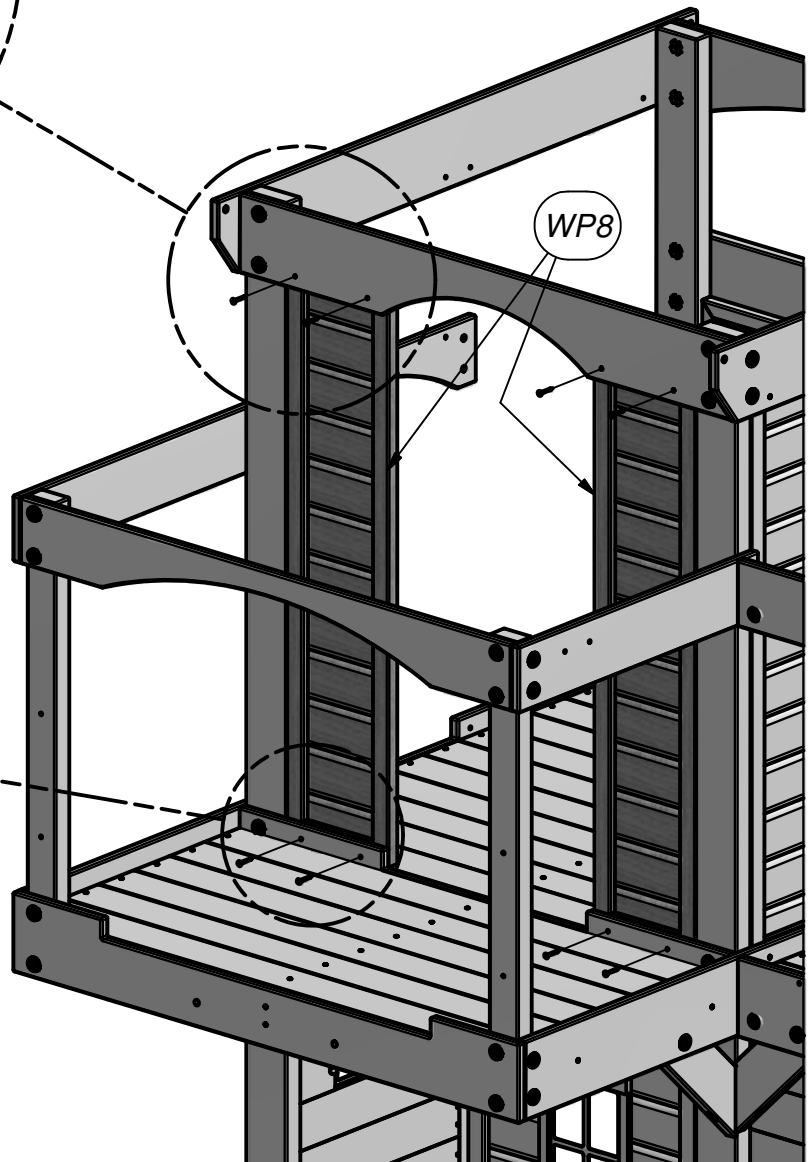

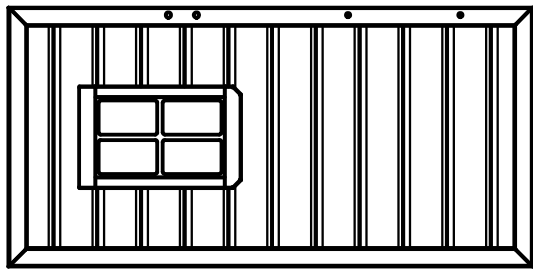

(1) WP5 - TOP LEFT REAR WALL PANEL - W2A02086
1"x16 7/8"x46 1/2" (24x430x971)

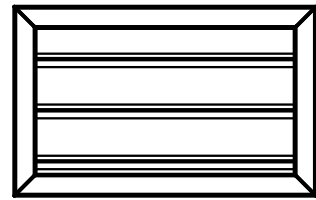

(1) WP6 - TOP REAR WALL PANEL - W2A02087
1"x18 7/8"x11 3/4" (24x479x300)

STEP 39

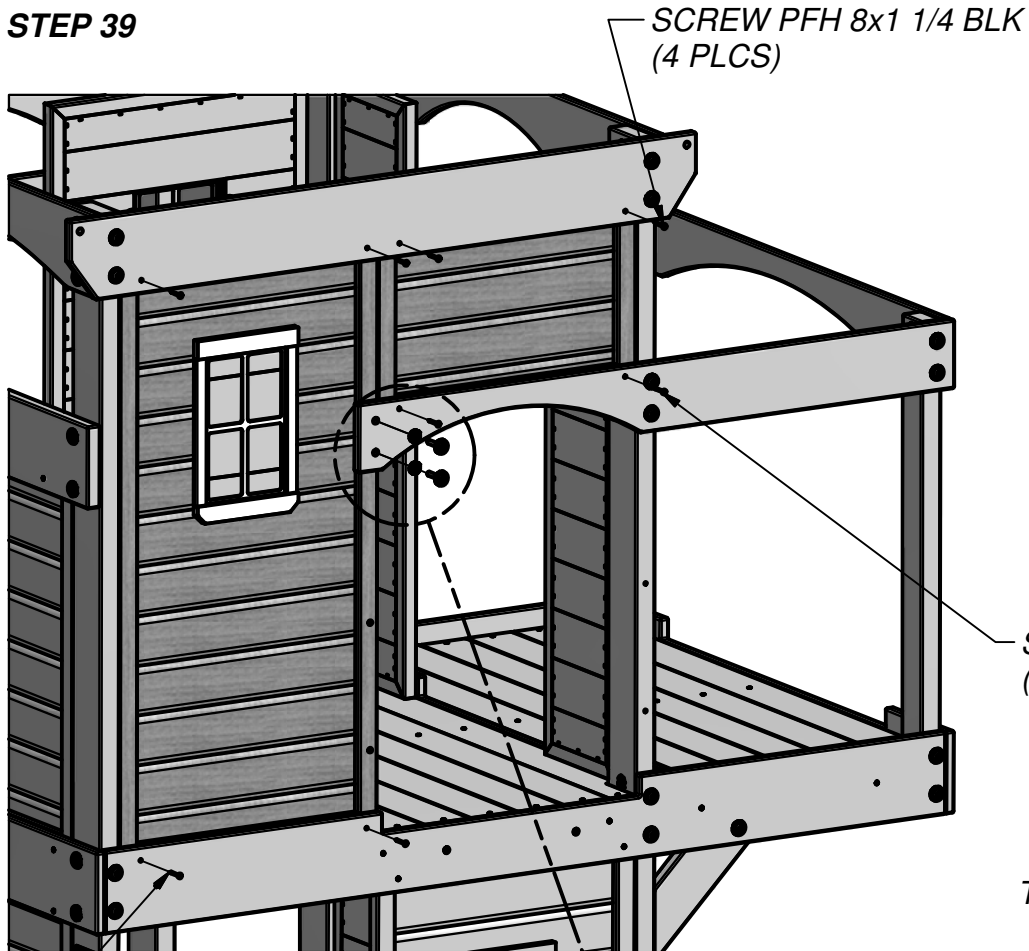

SCREW PFH 8x1 1/4 BLK
(4 PLCS)

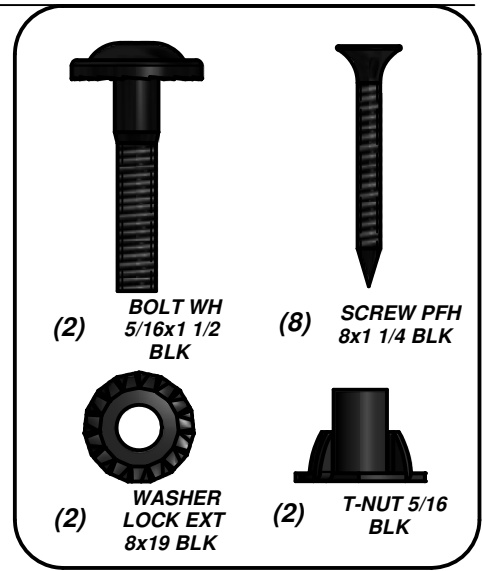

SCREW PFH 8x1 1/4 BLK
(2 PLCS)

100 mm [3 7/8 in]

T-NUT 5/16 BLK
(2 PLCS)

SCREW PFH 8x1 1/4 BLK
(2 PLCS)

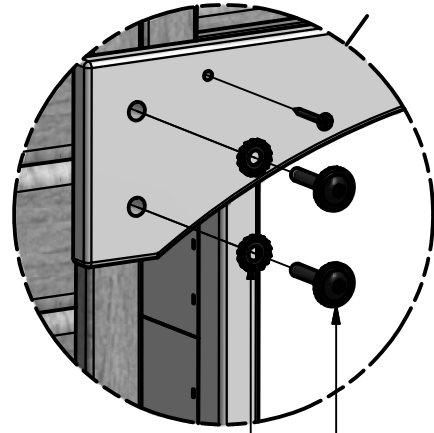

WASHER LOCK EXT 8x19 BLK
(2 PLCS)
BOLT WH 5/16x1 1/2 BLK
(2 PLCS)

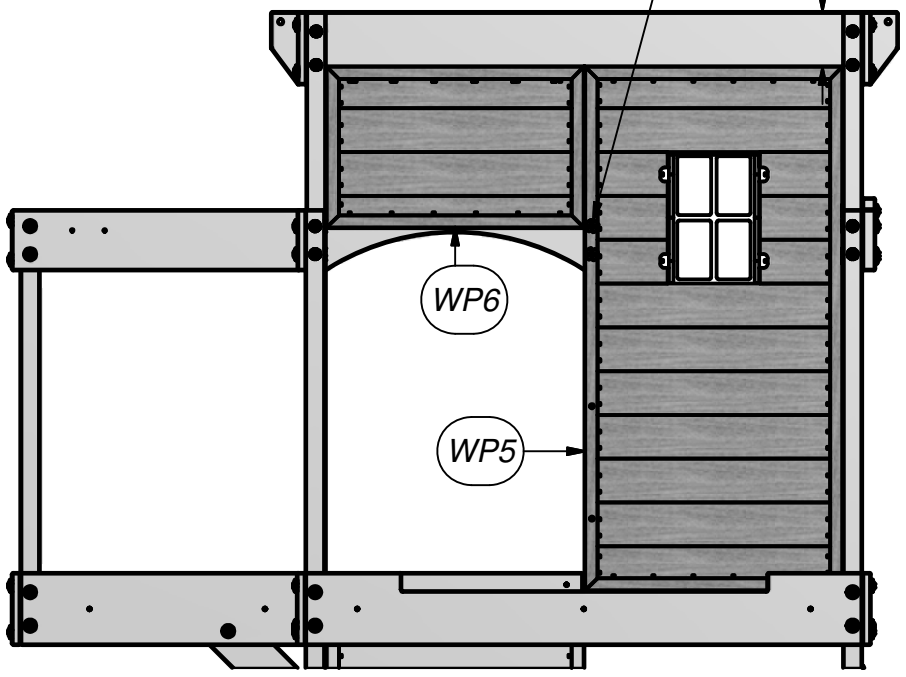



(8) N2 - PICKET - W4L07612
5/8"x2 3/8"x24 3/4" (16x60x628)

STEP 40

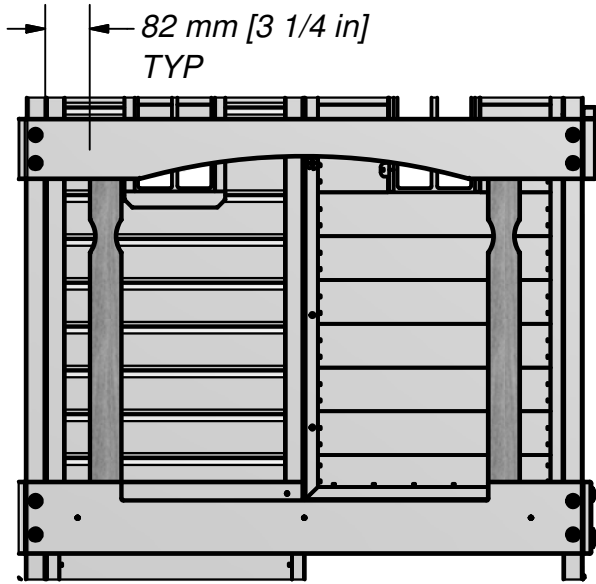

FRONT PICKET PLACEMENT

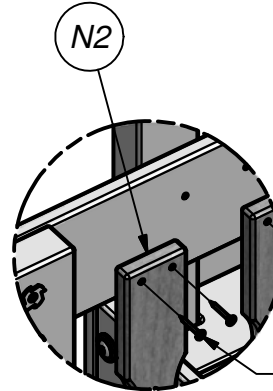

SCREW PFH 8x1 1/8
(32 PLCS)

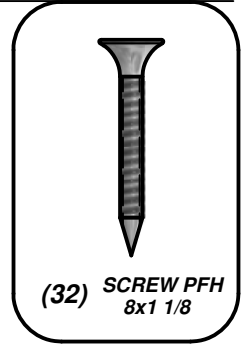

(32) SCREW PFH
8x1 1/8

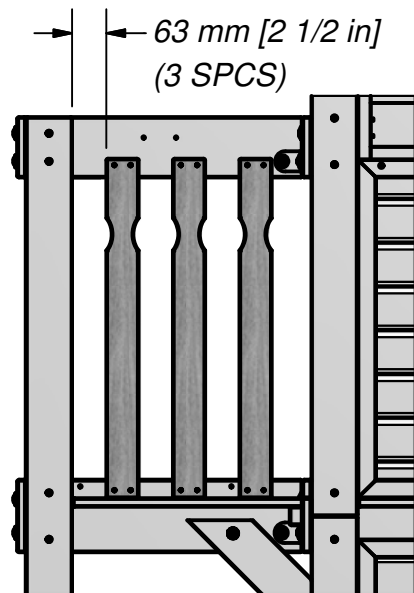

LEFT & RIGHT PICKET PLACEMENT

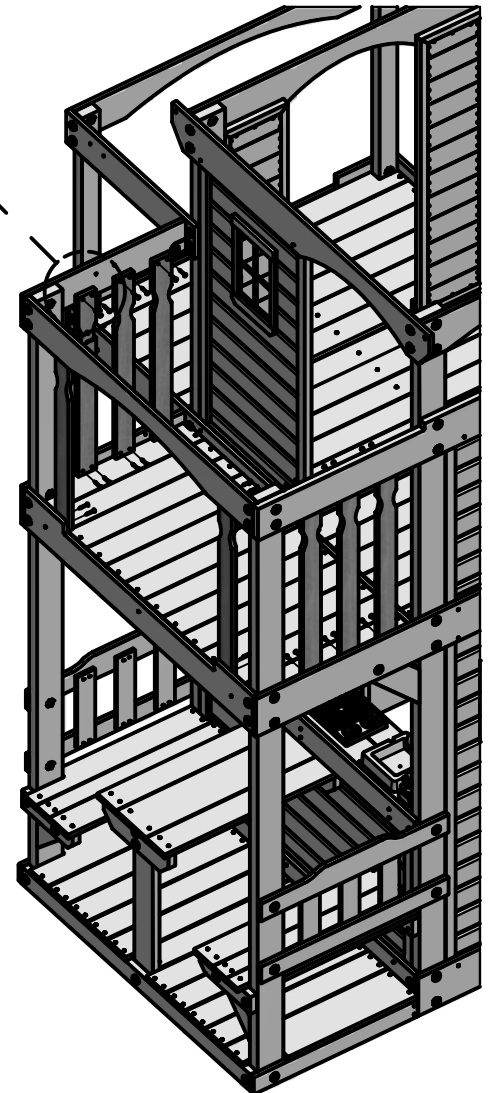

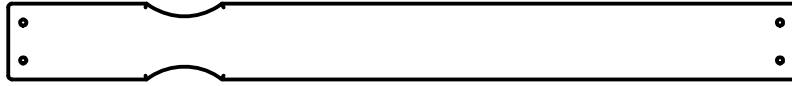

(10) **N2 - PICKET - W4L07612**
5/8"x2 3/8"x24 3/4" (16x60x628)

STEP 41

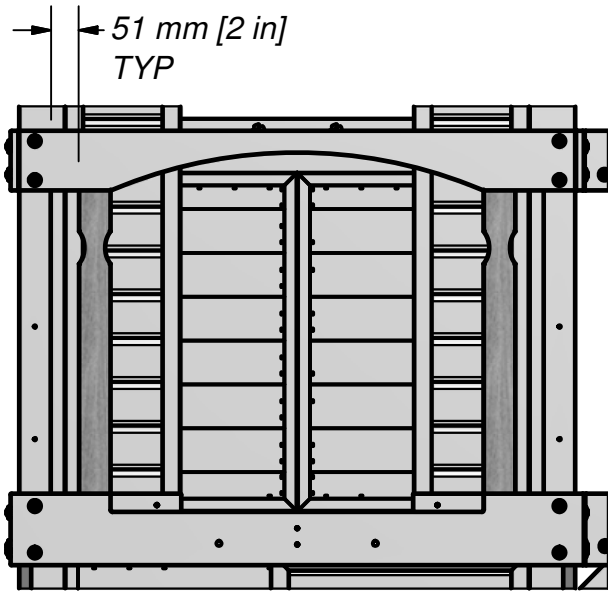

FRONT PICKET PLACEMENT

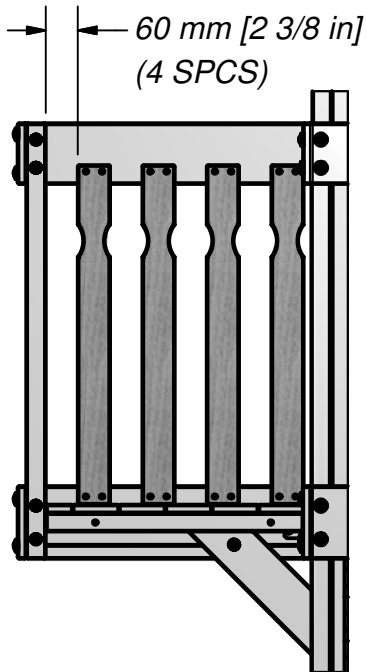

LEFT & RIGHT PICKET PLACEMENT

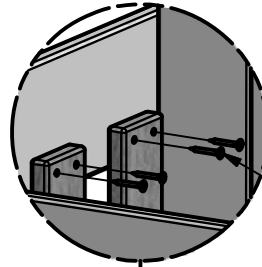

SCREW PFH 8x1 1/8
(40 PLCS)

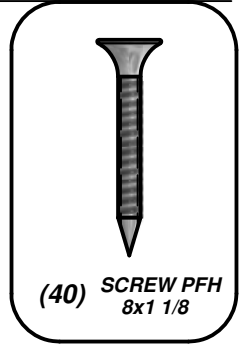

(40) **SCREW PFH**
8x1 1/8

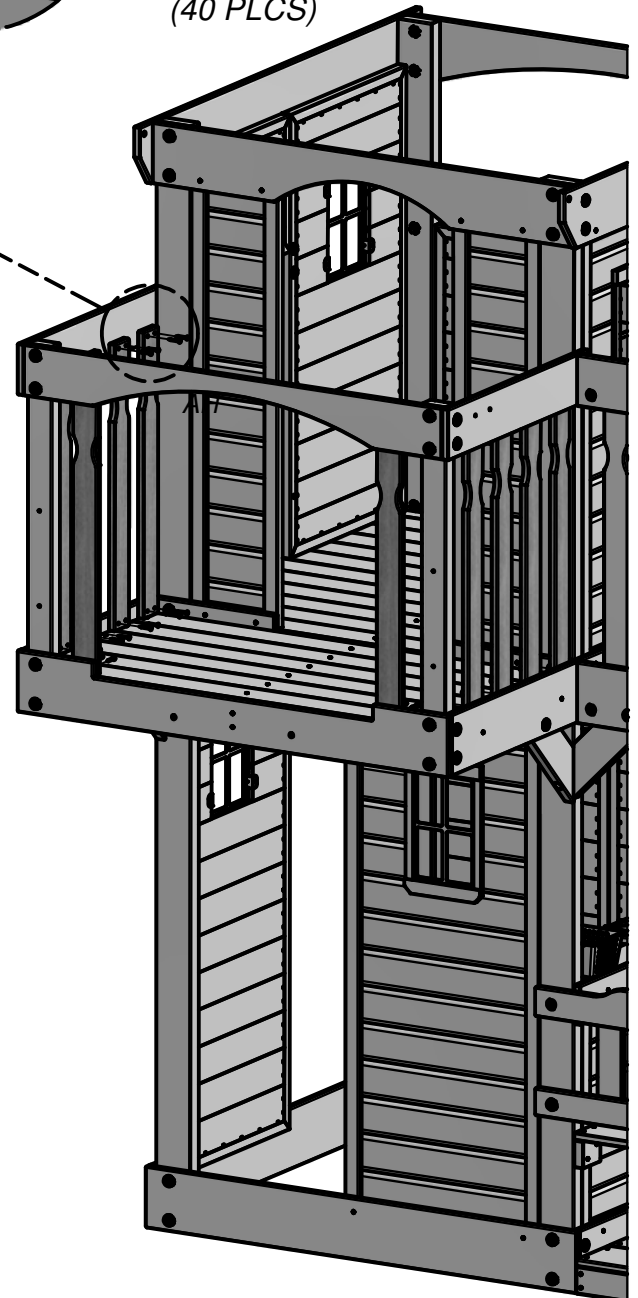

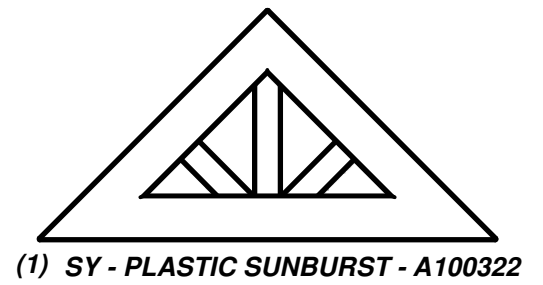
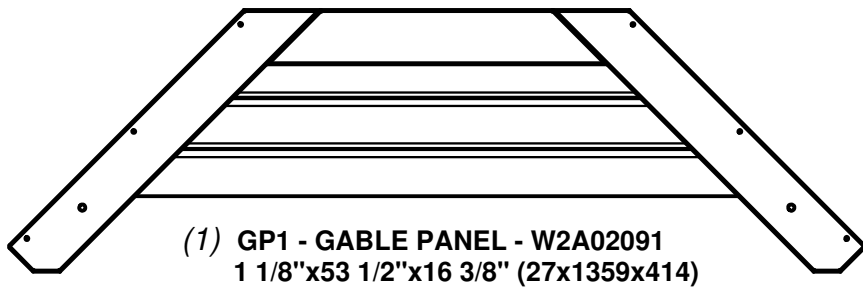

STEP 42

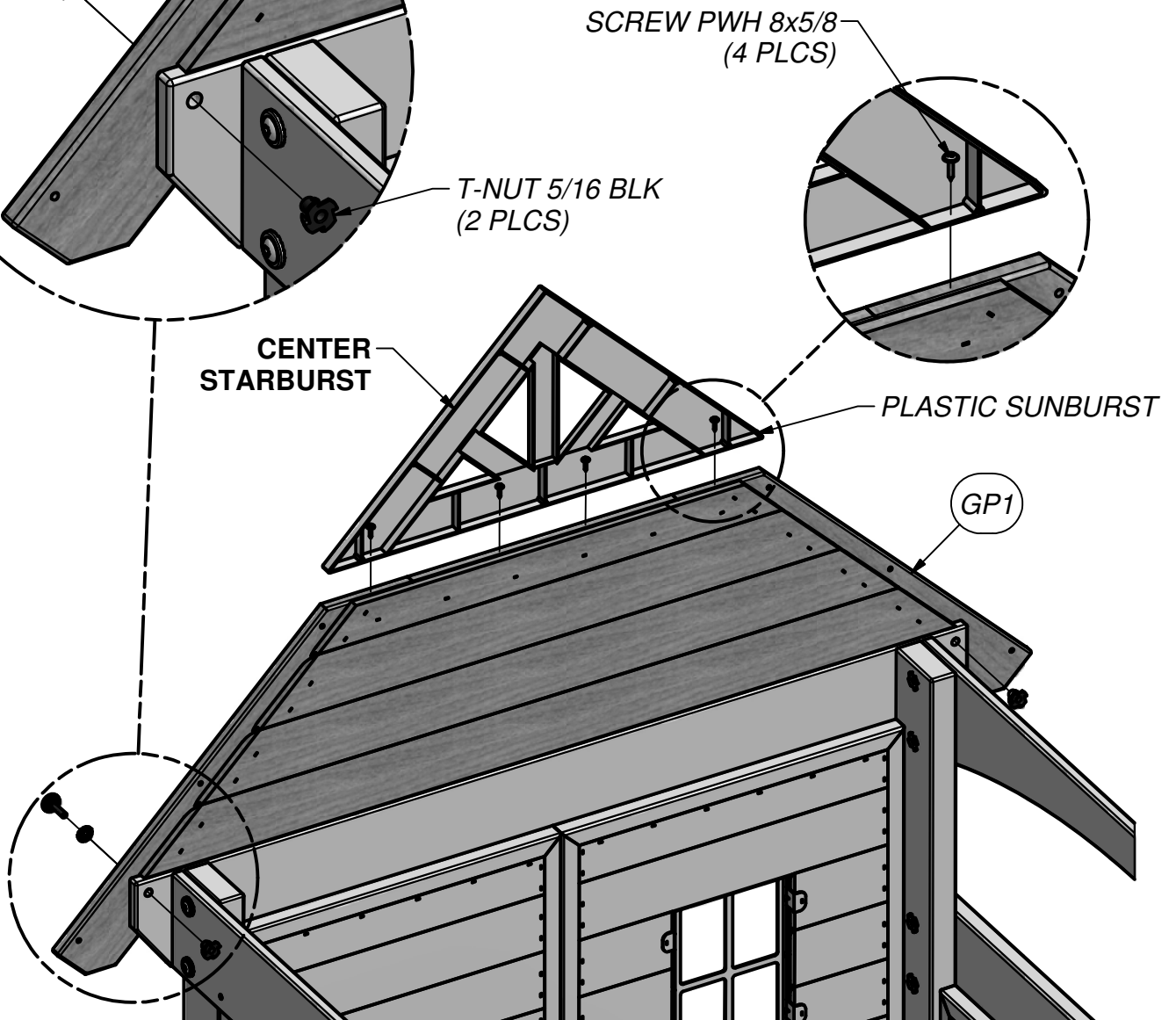
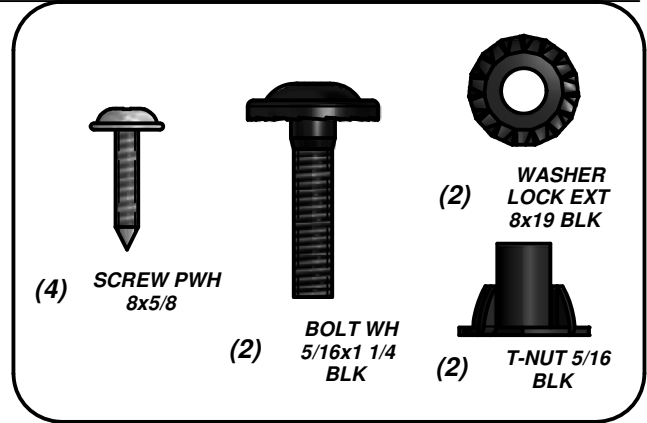
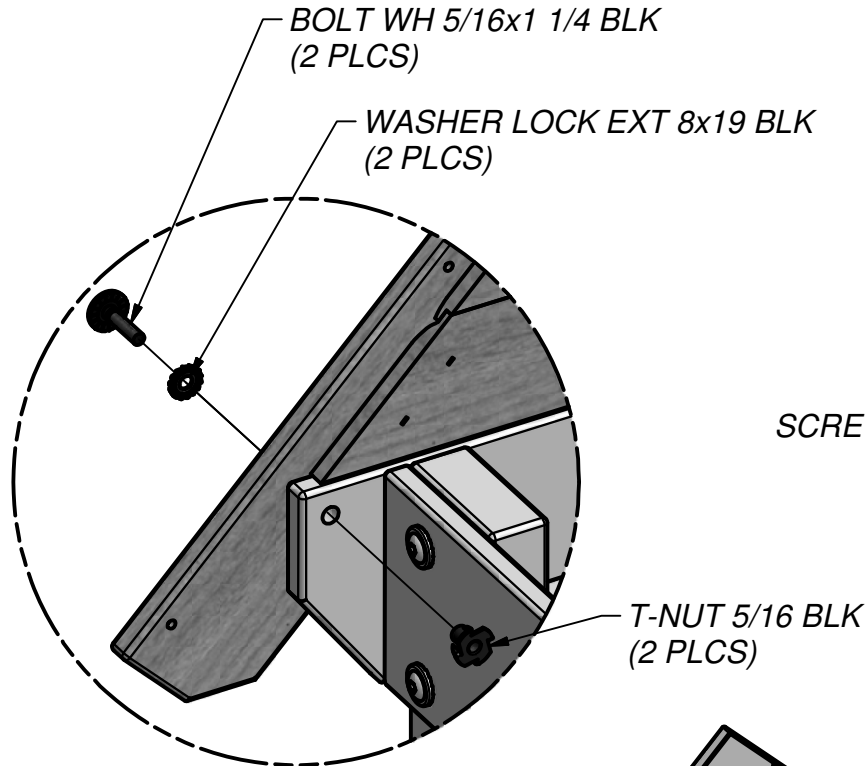

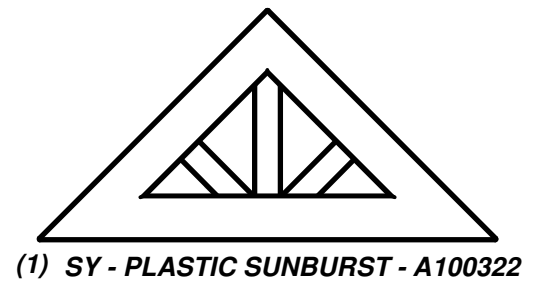
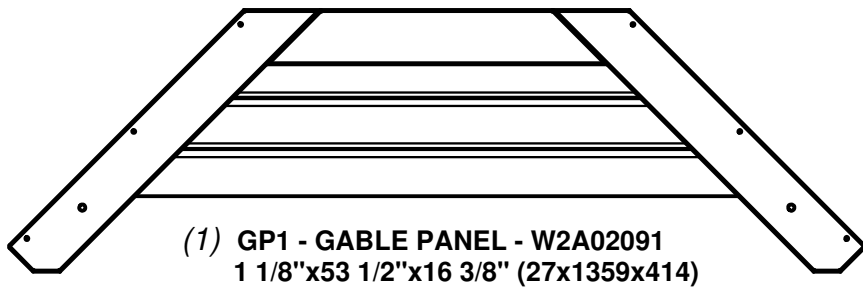

STEP 43

BOLT WH 5/16x1 1/4 BLK
(2 PLCS)

WASHER LOCK EXT 8x19 BLK
(2 PLCS)

(4) SCREW PWH
8x5/8

(2) BOLT WH
5/16x1 1/4
BLK

(2) WASHER
LOCK EXT
8x19 BLK

(2) T-NUT 5/16
BLK

T-NUT 5/16 BLK
(2 PLCS)

SCREW PWH 8x5/8
(4 PLCS)

CENTER
SUNBURST

PLASTIC SUNBURST

GP1

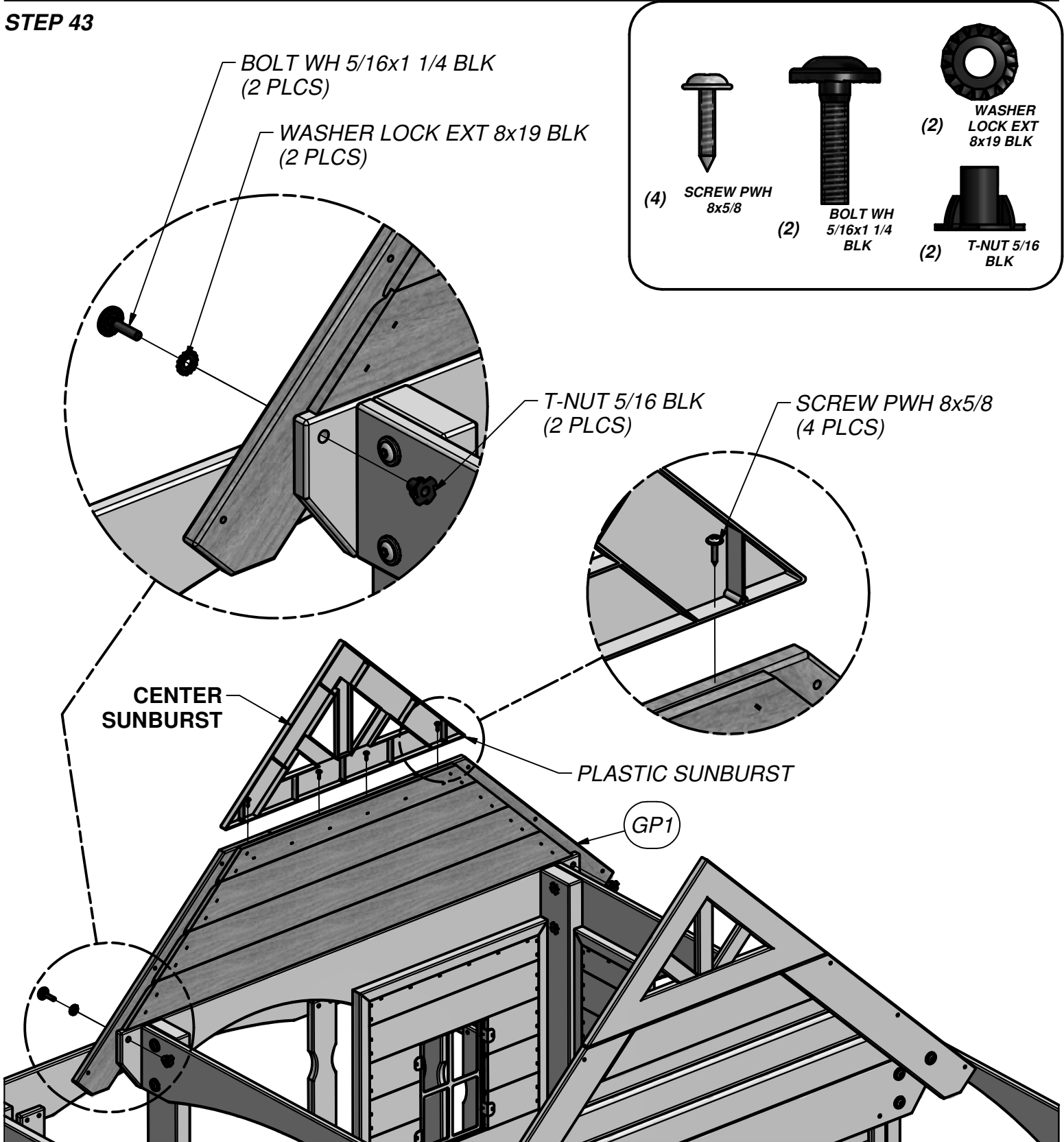

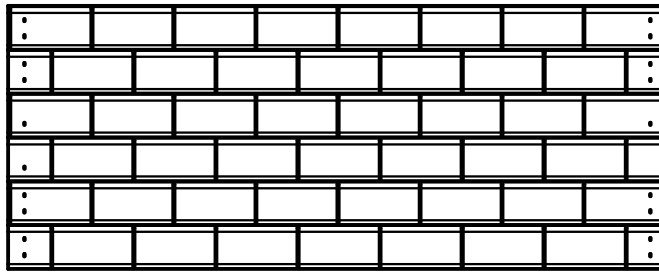

(2) RP2 - TOP ROOF PANEL - W2A02093
1 3/8"x48"x19 1/8" (35x1220x486)

STEP 44

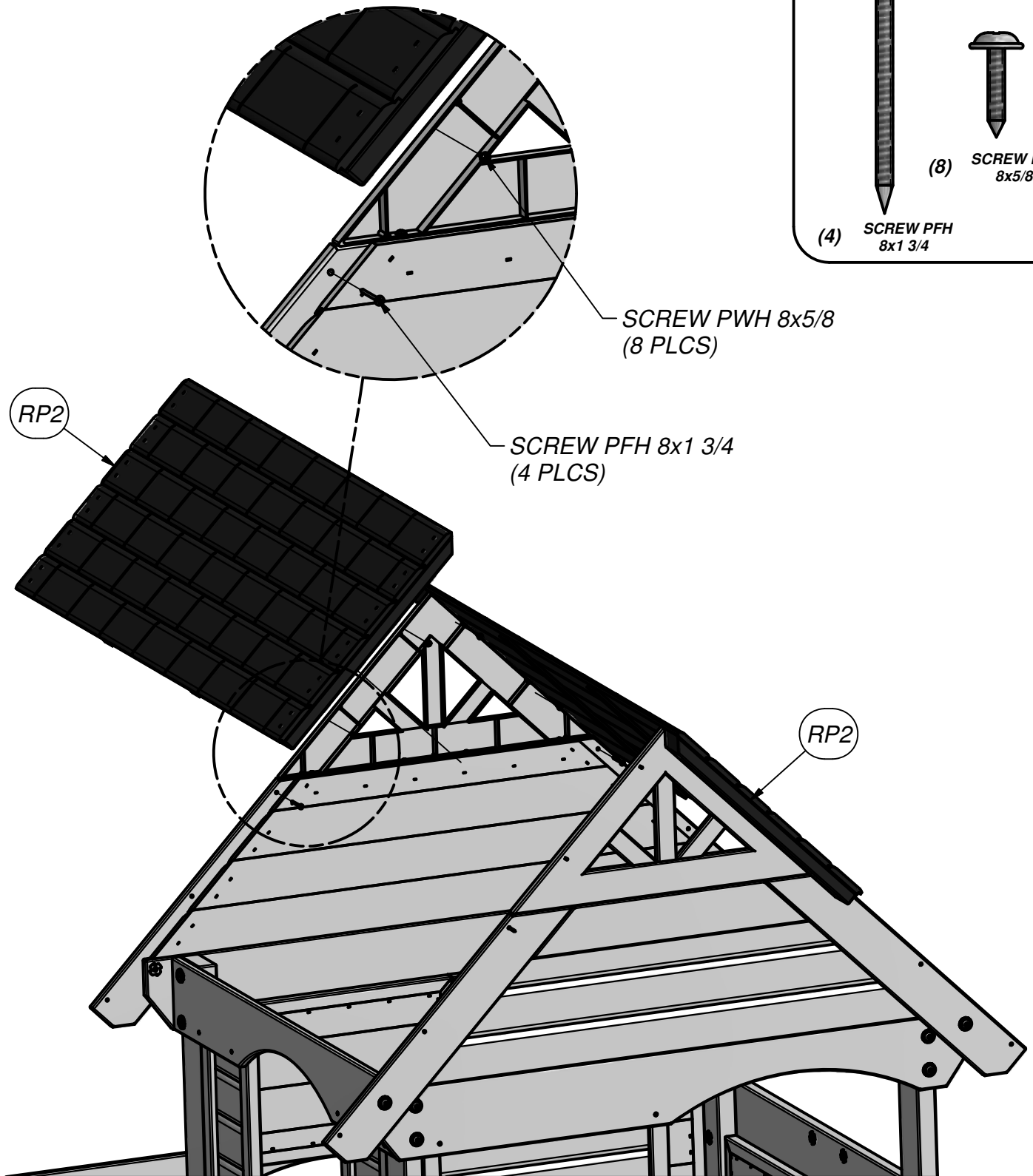
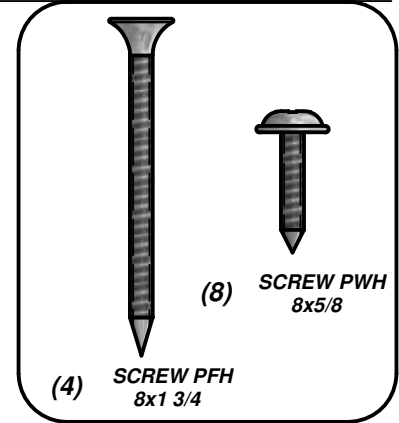

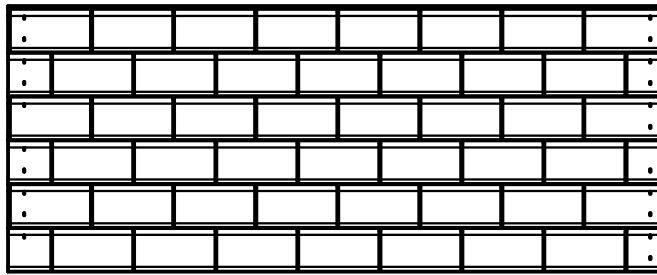

(2) RP1 - BOTTOM ROOF PANEL - W2A02092
1 3/8"x48"x19 3/8" (35x1220x491)

STEP 45

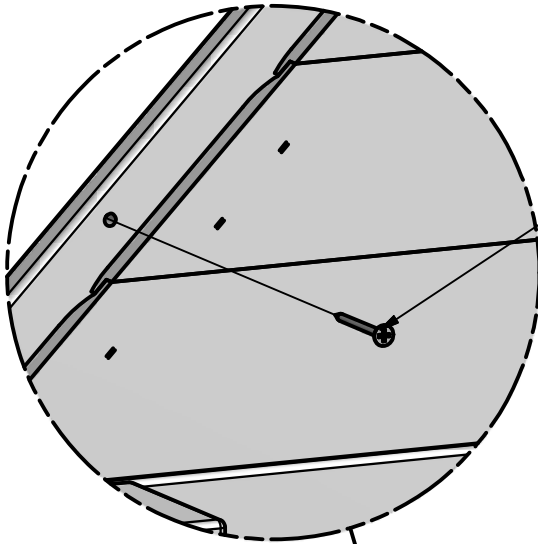

SCREW PFH 8x1 3/4
(8 PLCS)

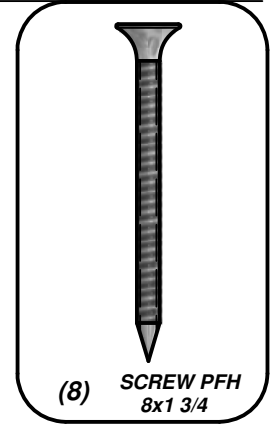

(8) SCREW PFH
8x1 3/4

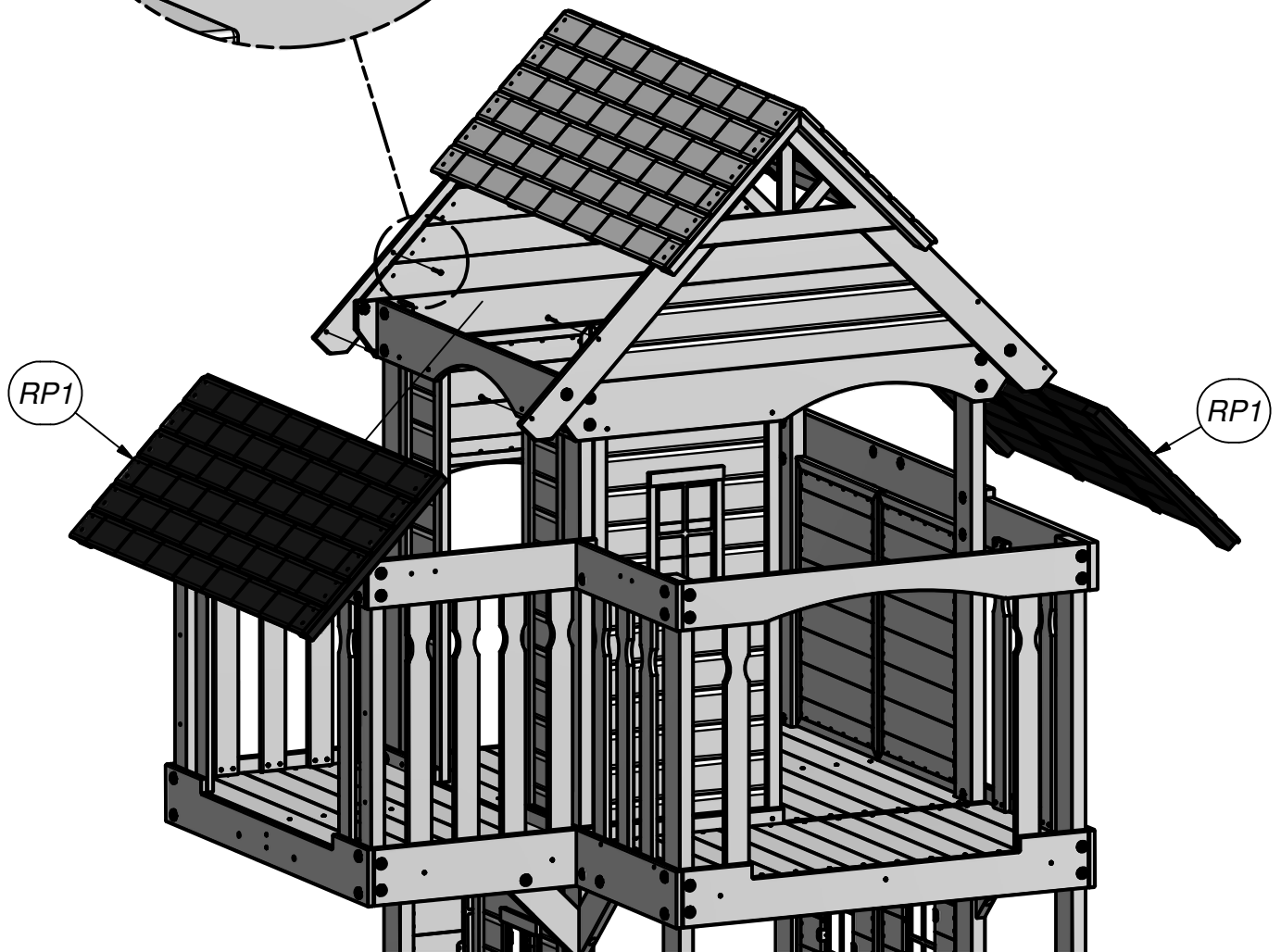

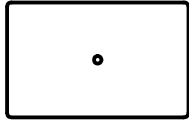

(1) **E10 - MOUNTING BLOCK - W4L07615**
 1 3/8"x3"x4 3/4" (36x76x120)

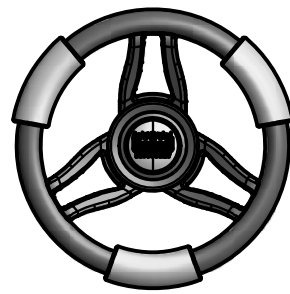

(1) **LP - STEERING WHEEL - A100105**

STEP 46

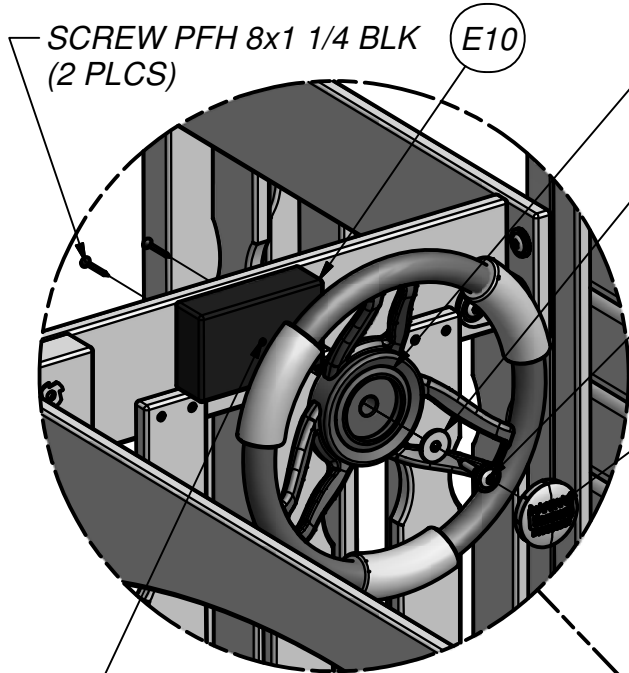

SCREW PFH 8x1 1/4 BLK
 (2 PLCS)

E10

STEERING WHEEL

WASHER FLAT 8x27
 (INCLUDED IN KIT)

LAG SCREW WH 5/16x1 1/2
 (INCLUDED IN KIT)

PLASTIC CAP
 (INCLUDED IN KIT)

NOTE HOLE LOCATION
 FOR PROPER ORIENTATION.

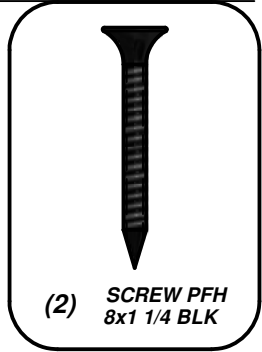

(2) **SCREW PFH**
 8x1 1/4 BLK

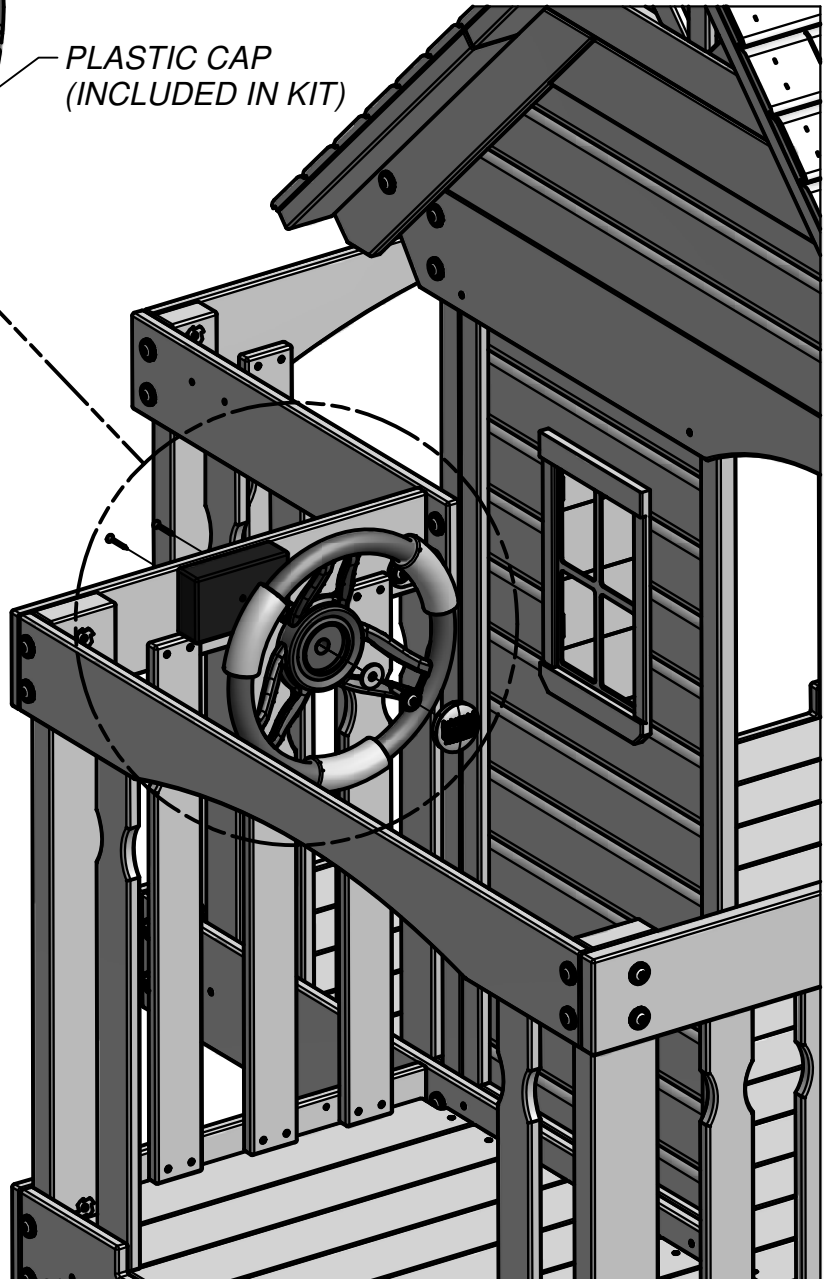

THIS HOLE FACES THE RAIL IN THIS STEP.

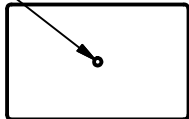

- (1) E10 - MOUNTING BLOCK - W4L07615
1 3/8"x3"x4 3/4" (36x76x120)

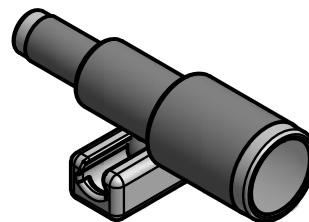

- (1) LN - Telescope - A6P00096

STEP 47

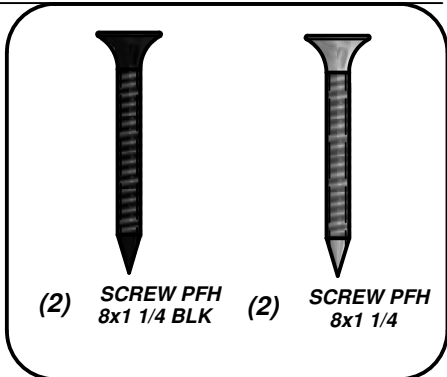
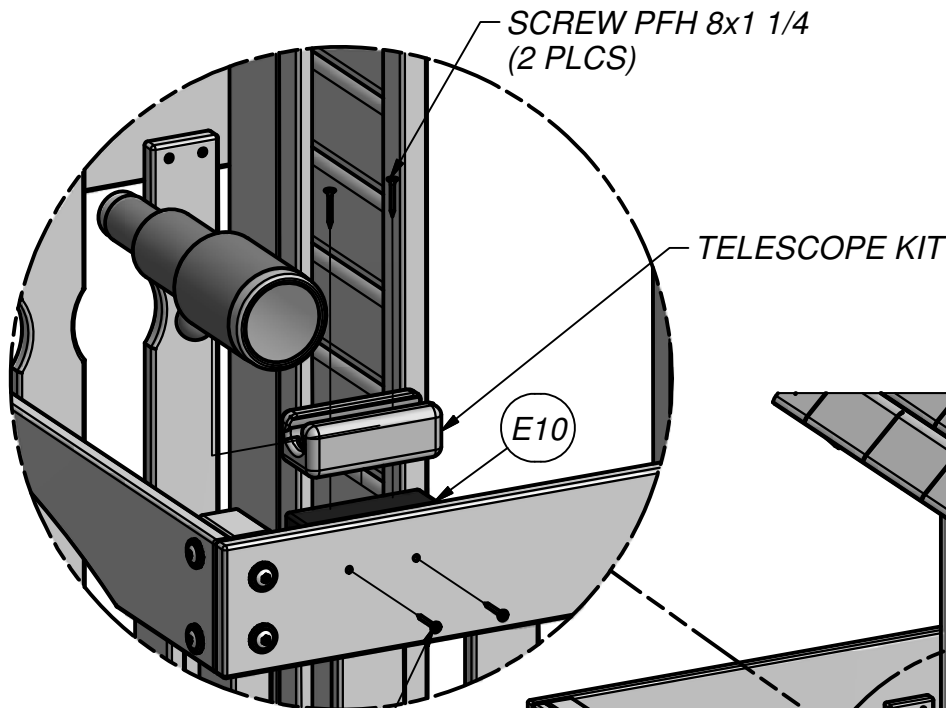

- SCREW PFH 8x1 1/4 BLK
(2 PLCS)

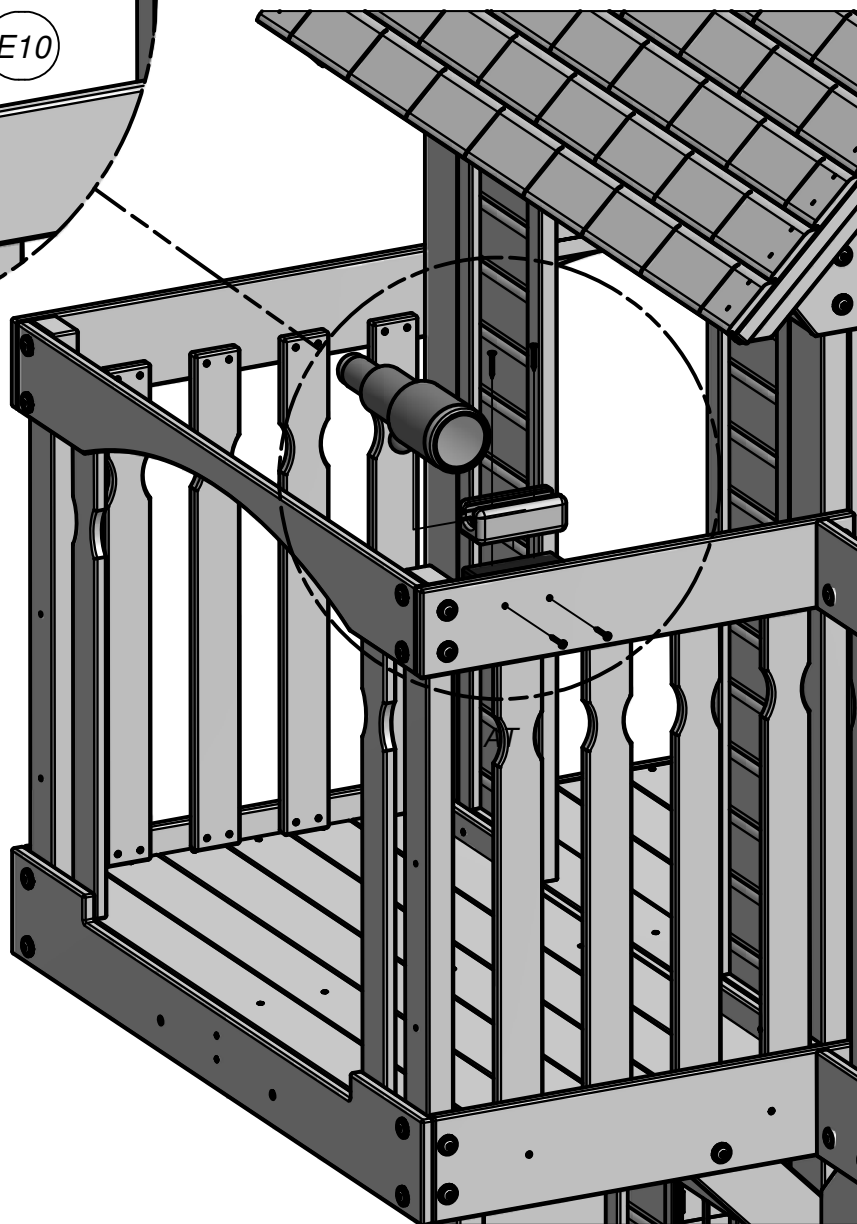

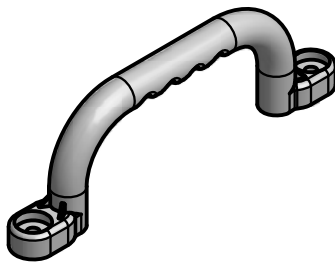

(2) EA - HAND GRIP YELLOW PLASTIC - A100043

STEP 48

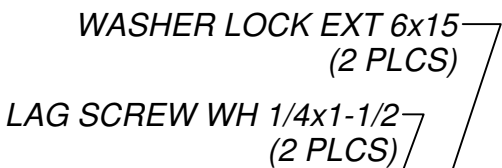
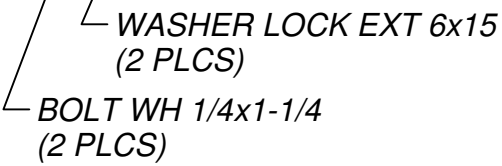
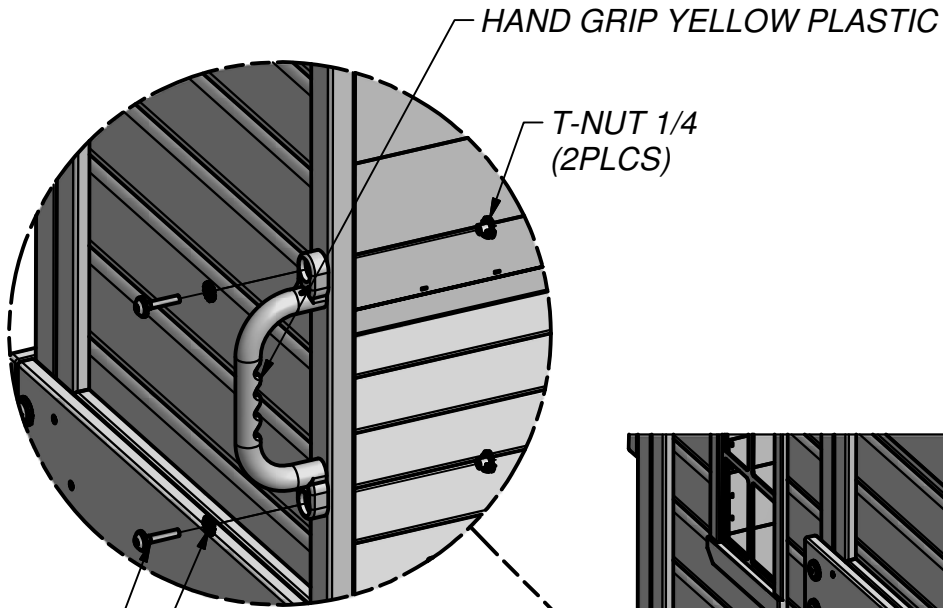
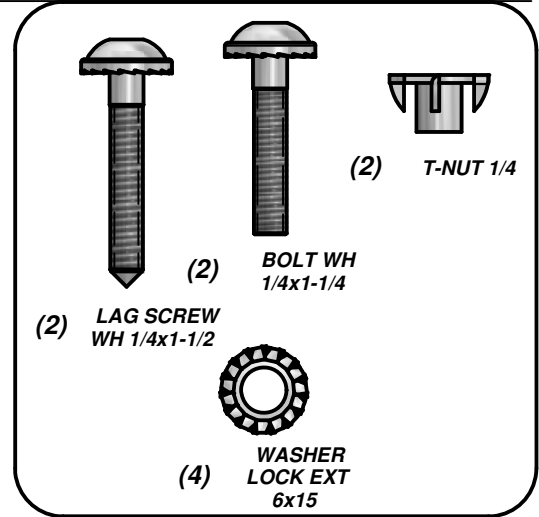

HAND GRIP YELLOW PLASTIC

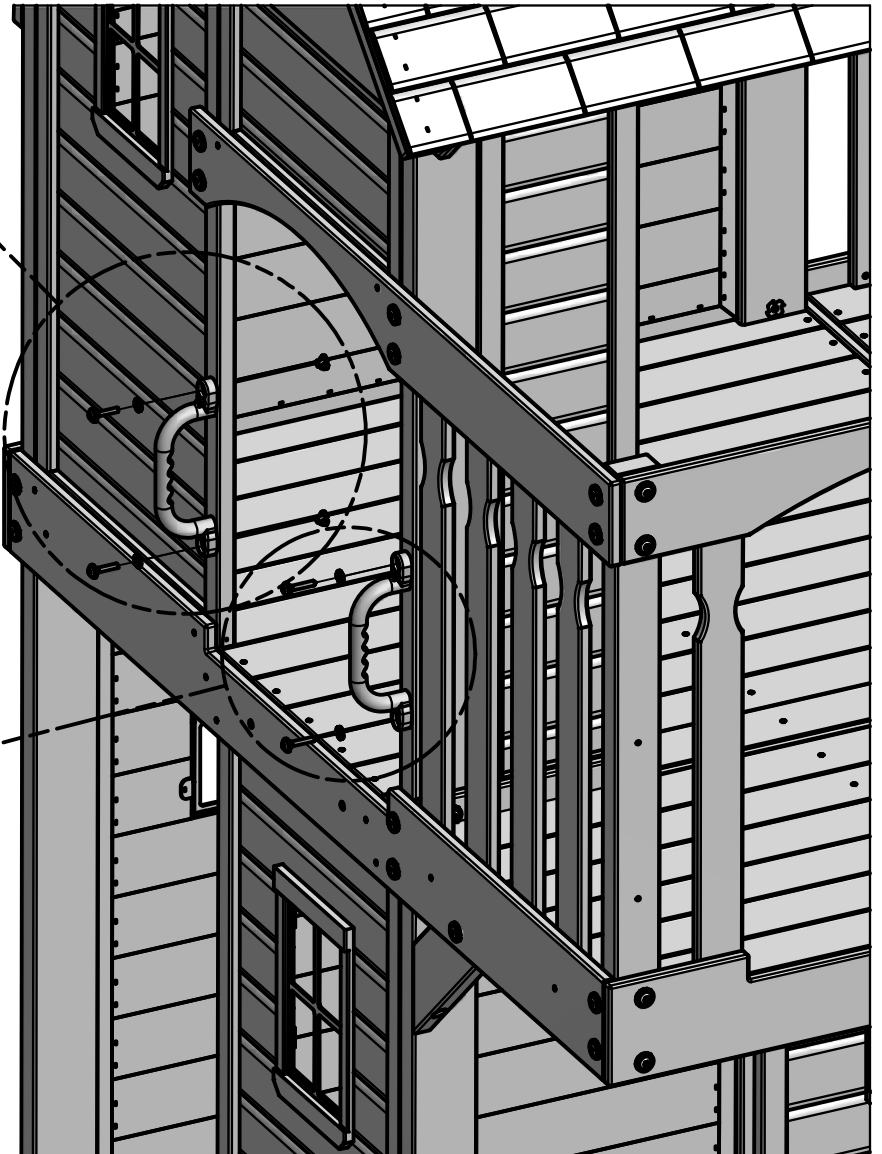

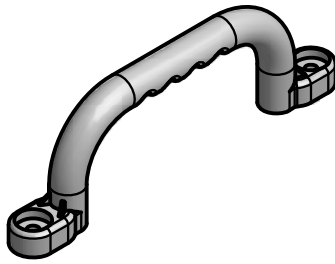

(2) EA - HAND GRIP YELLOW PLASTIC - A100043

STEP 49

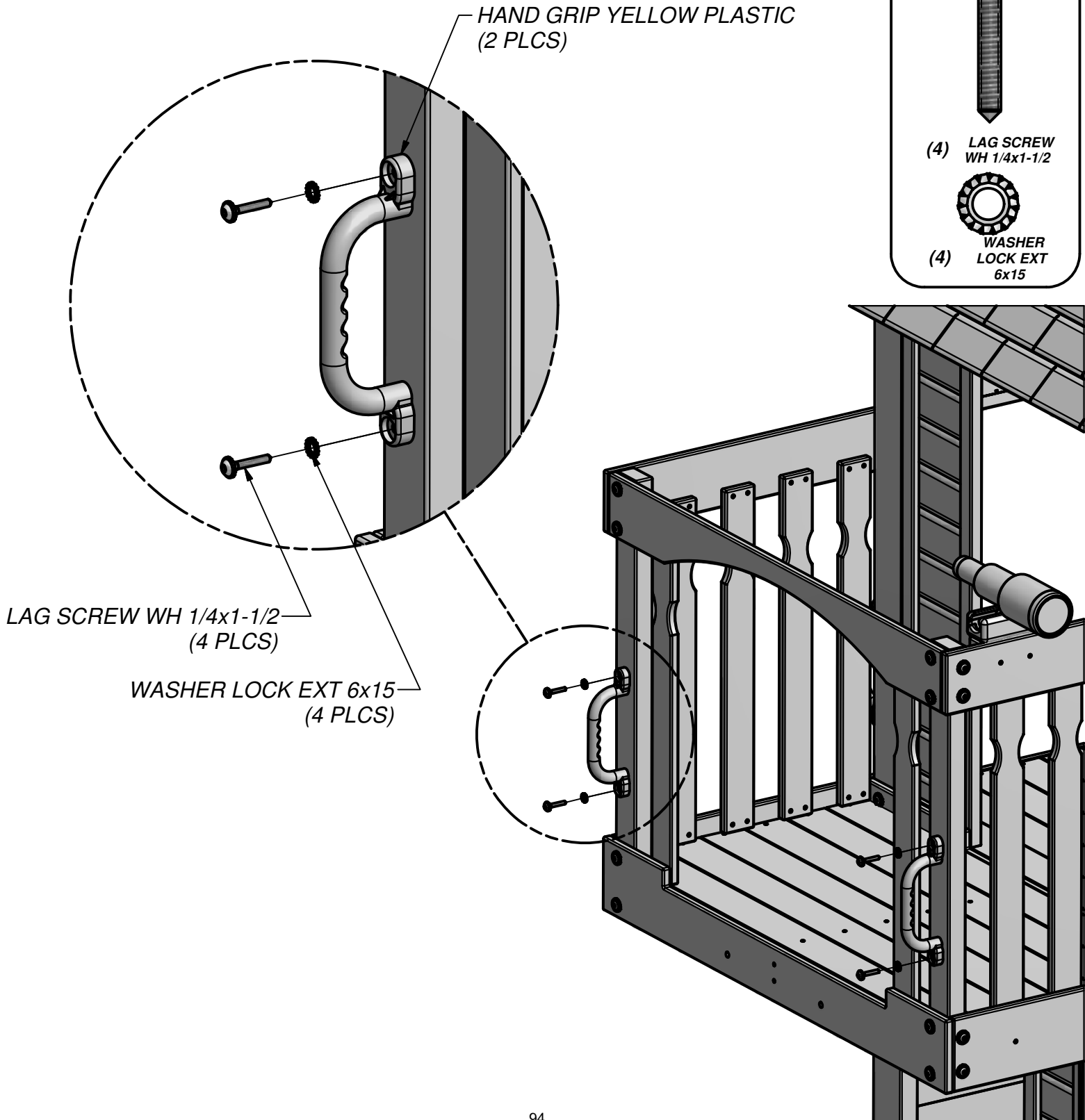

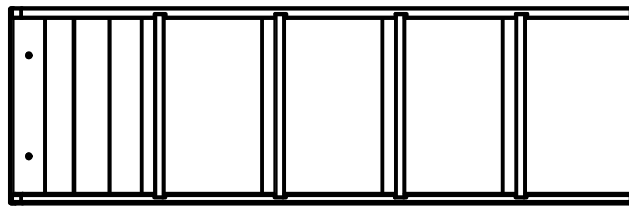

(1) LADDER ASSEMBLY

STEP 50

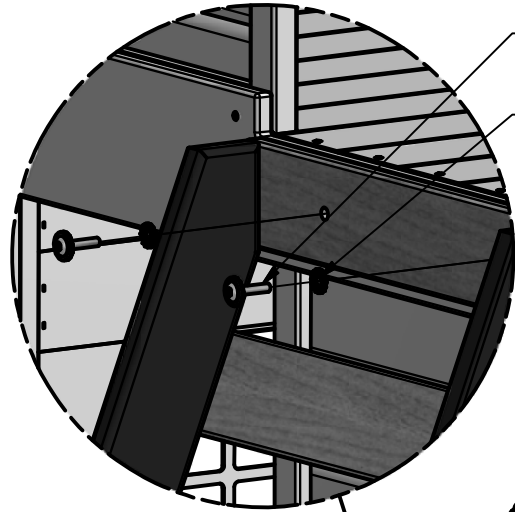

- BOLT WH 5/16x1 1/4 BLK
(2 PLCS)
- WASHER LOCK EXT 8x19 BLK
(2 PLCS)



(2) BOLT WH
5/16x1 1/4
BLK



(2) WASHER
LOCK EXT
8x19 BLK

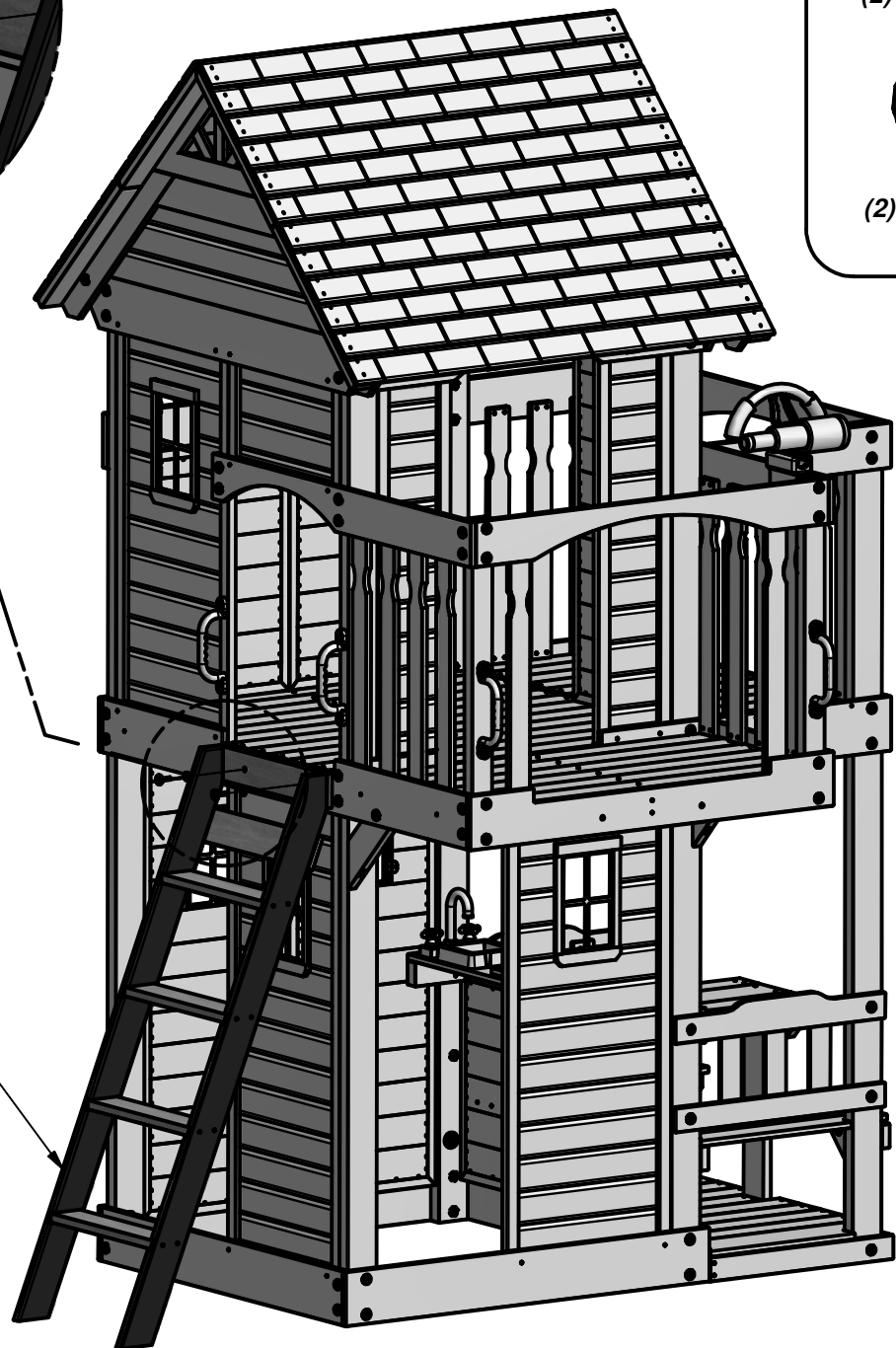

LADDER ASSEMBLY

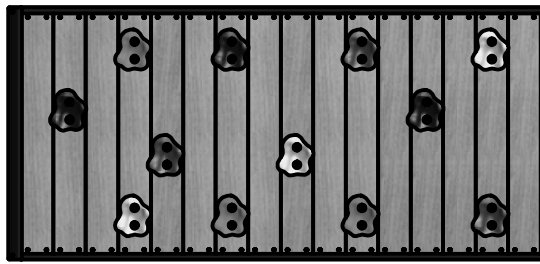

(1) ROCKWALL ASSEMBLY

STEP 51

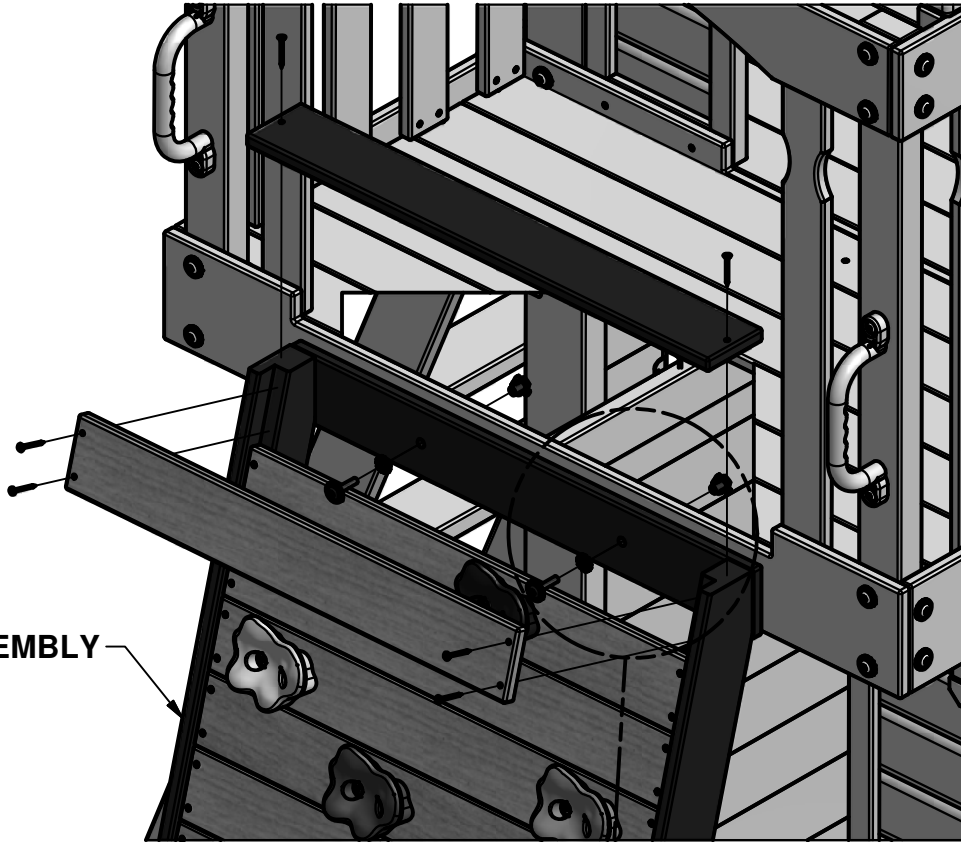

ROCKWALL ASSEMBLY

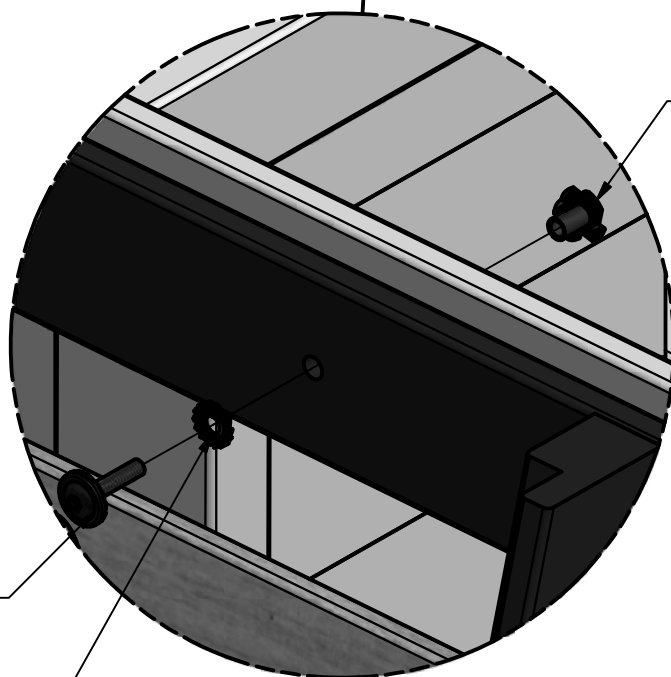
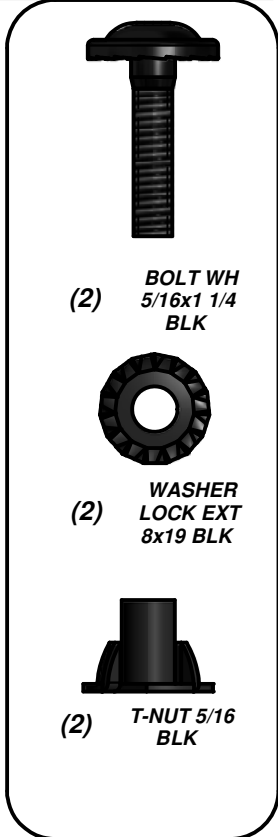

T-NUT 5/16 BLK
(2 PLCS)

BOLT WH 5/16x1 1/4 BLK
(2 PLCS)

WASHER LOCK EXT 8x19 BLK
(2 PLCS)

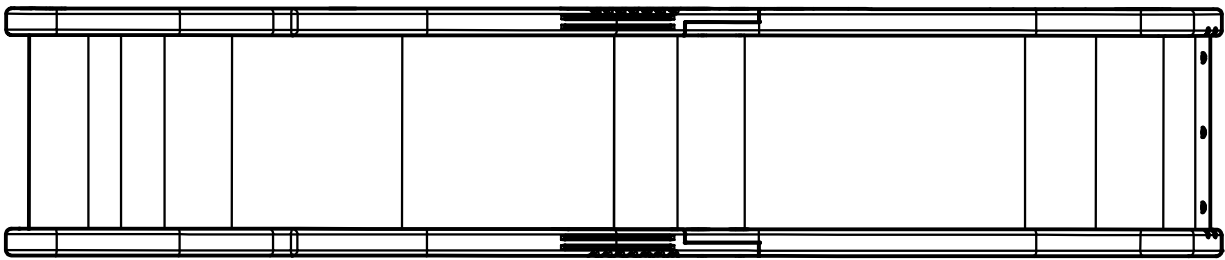

(1) 10' SLIDE ASSEMBLY

STEP 52

USE A 7/16" DRILL BIT.

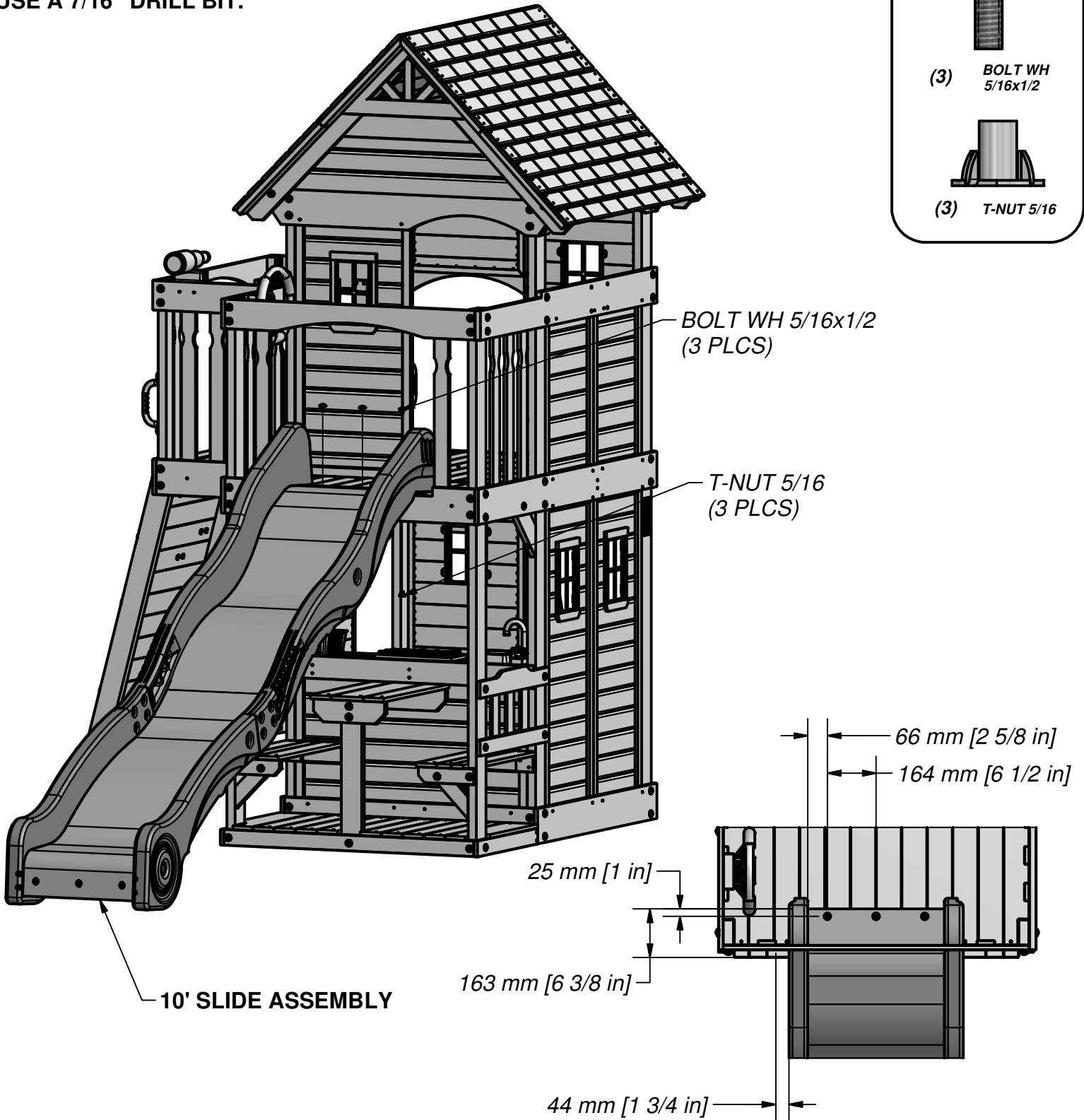
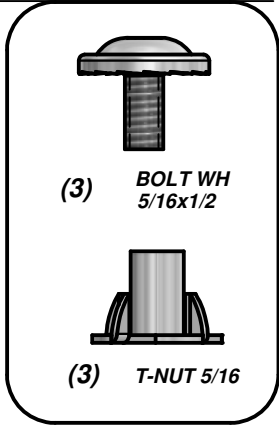

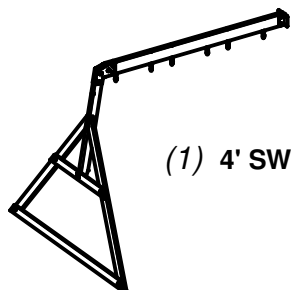

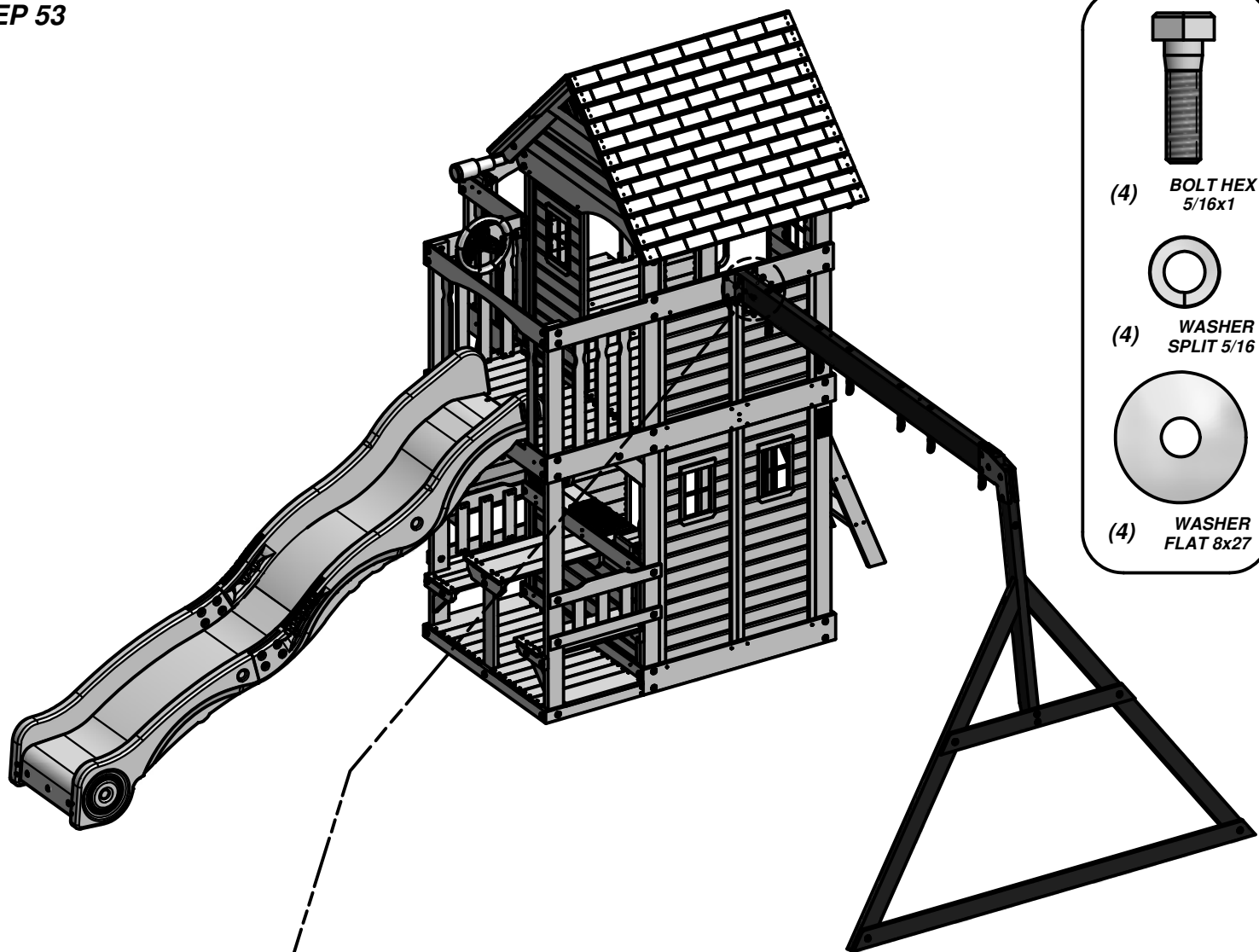

(1) 4' SWING BEAM ASSEMBLY

STEP 53

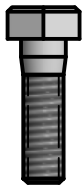

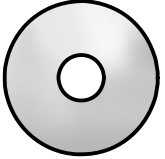
- 
(4) BOLT HEX 5/16x1
- 
(4) WASHER SPLIT 5/16
- 
(4) WASHER FLAT 8x27

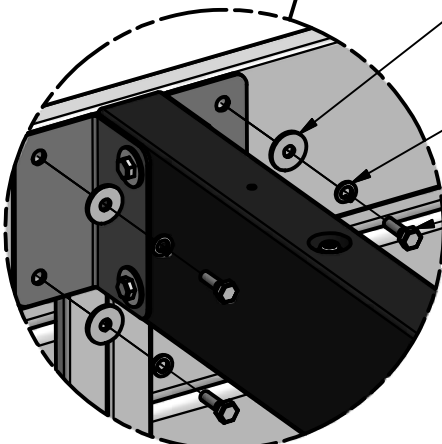
- 
WASHER FLAT 8x27
(4 PLCS)
- WASHER SPLIT 5/16
(4 PLCS)
- BOLT HEX 5/16x1
(4 PLCS)

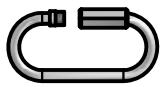

(6) FA - QUICK LINK - A100069



(2) DP - SWING SEAT GREEN - A100027



(1) - TRAPEZE - A6P00034



(2) KN - CHAIN GREEN 31" - A100177



(4) EZ - CHAIN GREEN 51.25" - A100068

STEP 54

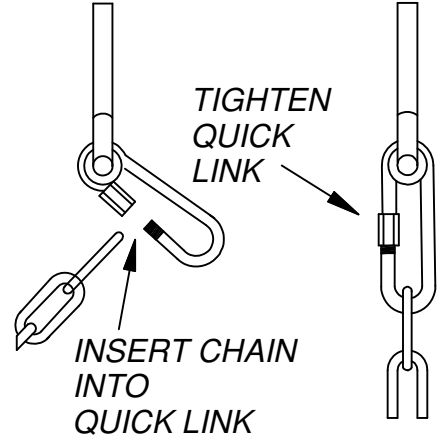
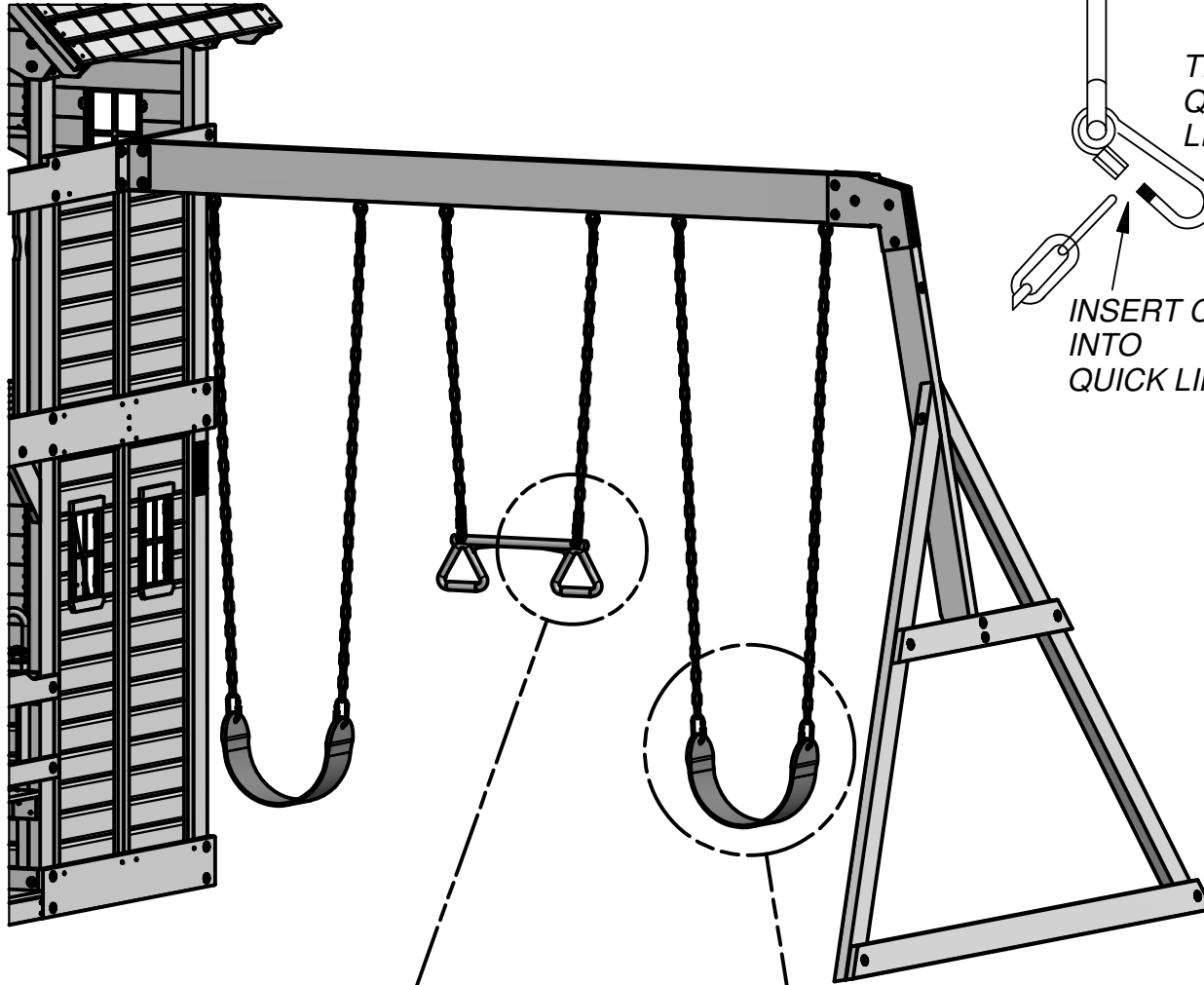

TIGHTEN QUICK LINK

INSERT CHAIN INTO QUICK LINK

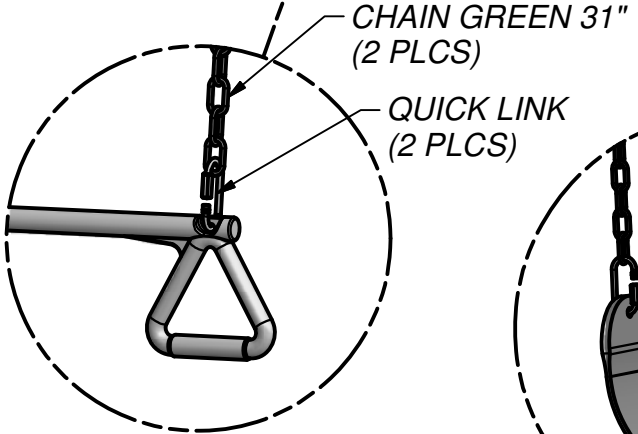

CHAIN GREEN 31" (2 PLCS)

QUICK LINK (2 PLCS)

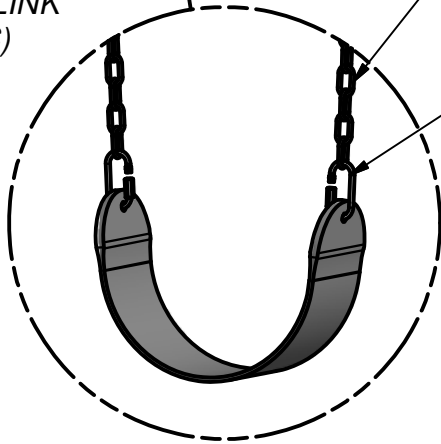

CHAIN GREEN 51.25" (4 PLCS)

QUICK LINK (4 PLCS)



(1) HC - BYD ID TAG (LARGE) WITHOUT AGES - A100242

STEP 55

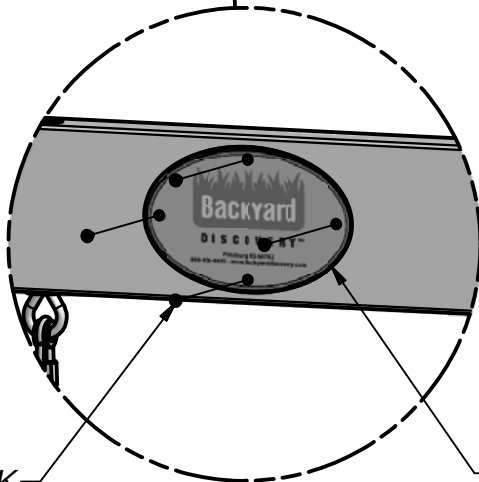
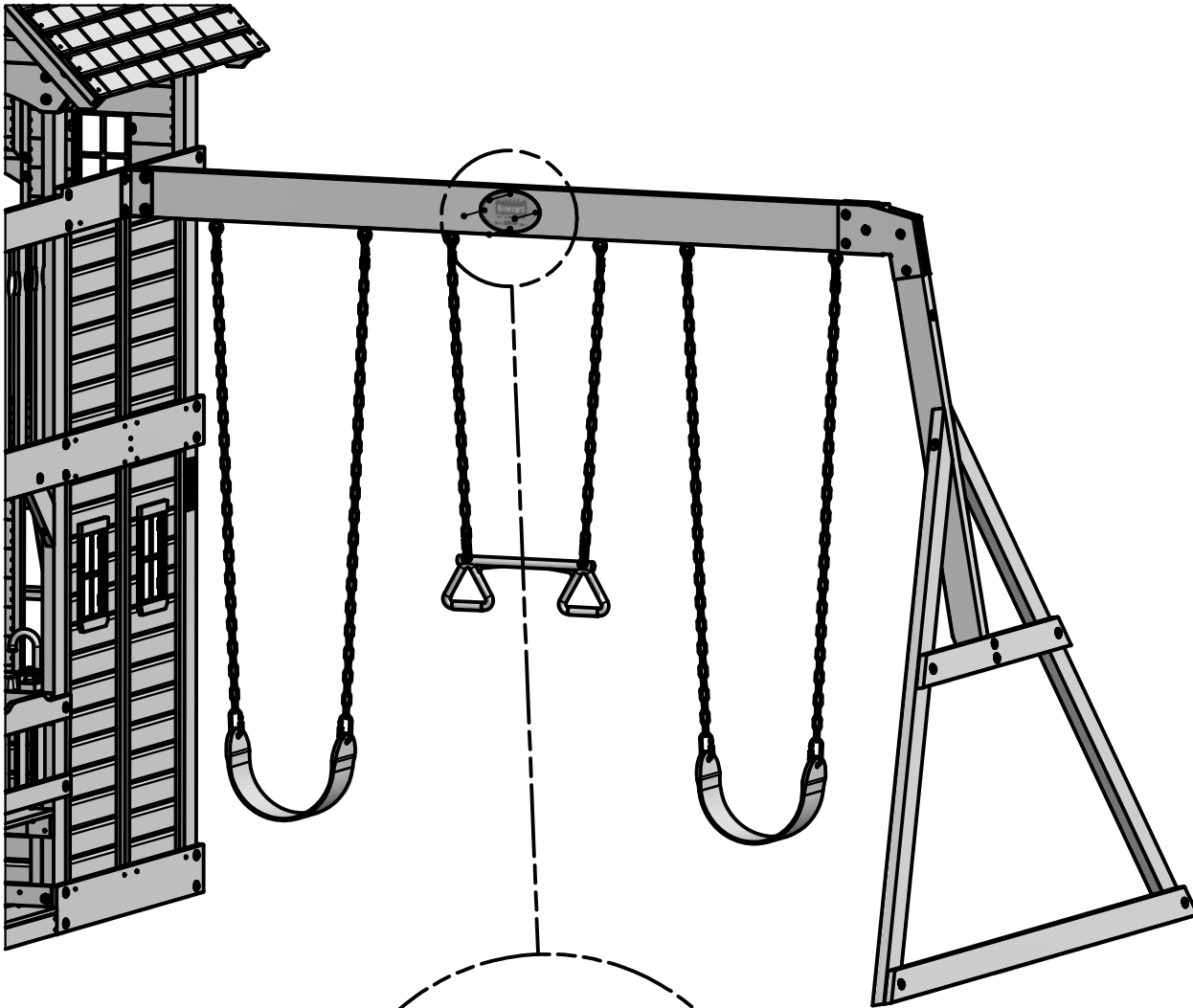
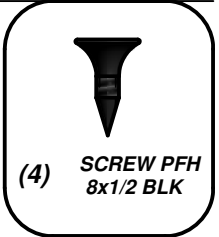

SCREW PFH 8x1/2 BLK
(4 PLCS)

BYD ID TAG (LARGE) WITHOUT AGES

Anchoring Instructions

STEP 56

TAP IN GROUND STAKES AT AN APPROXIMATE 45° ANGLE AT THE LOCATIONS SHOWN. USING GROUND STAKES AS A GUIDE, DRILL 7/16" DIA HOLES.

NOTE:

FAILURE TO USE GROUND STAKES CAN VOID WARRANTY & CAUSE INJURY!

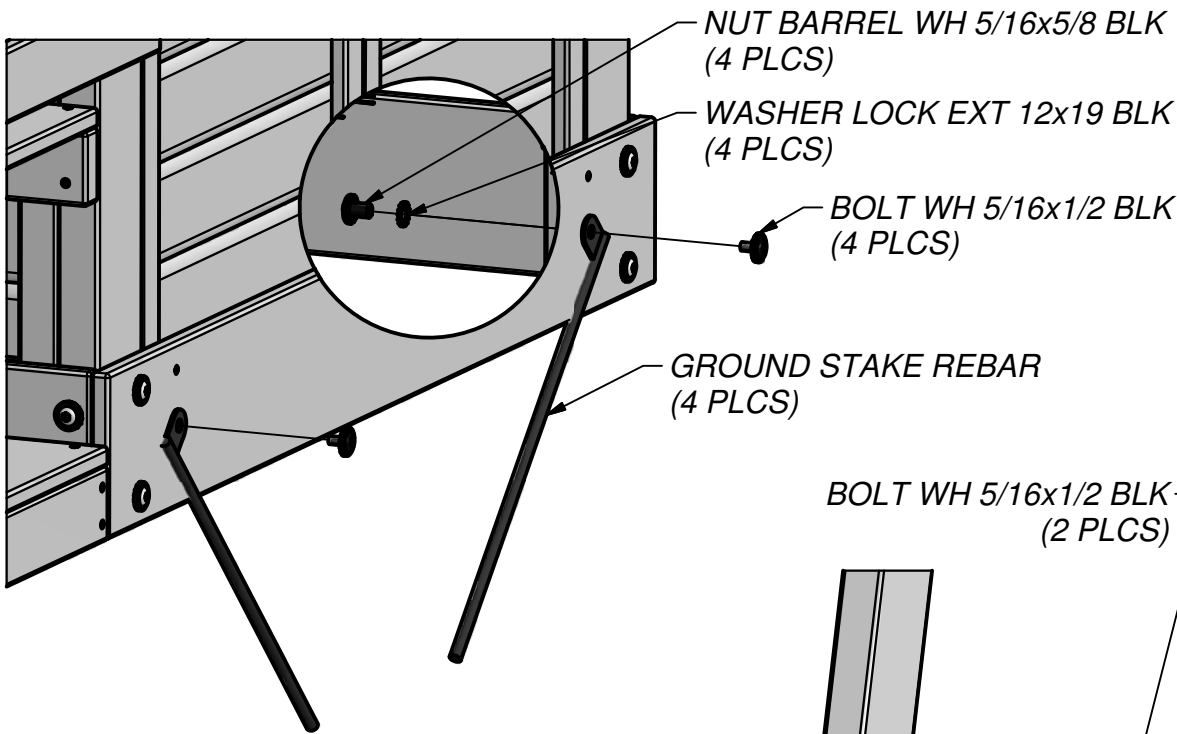

FORT GROUND STAKES

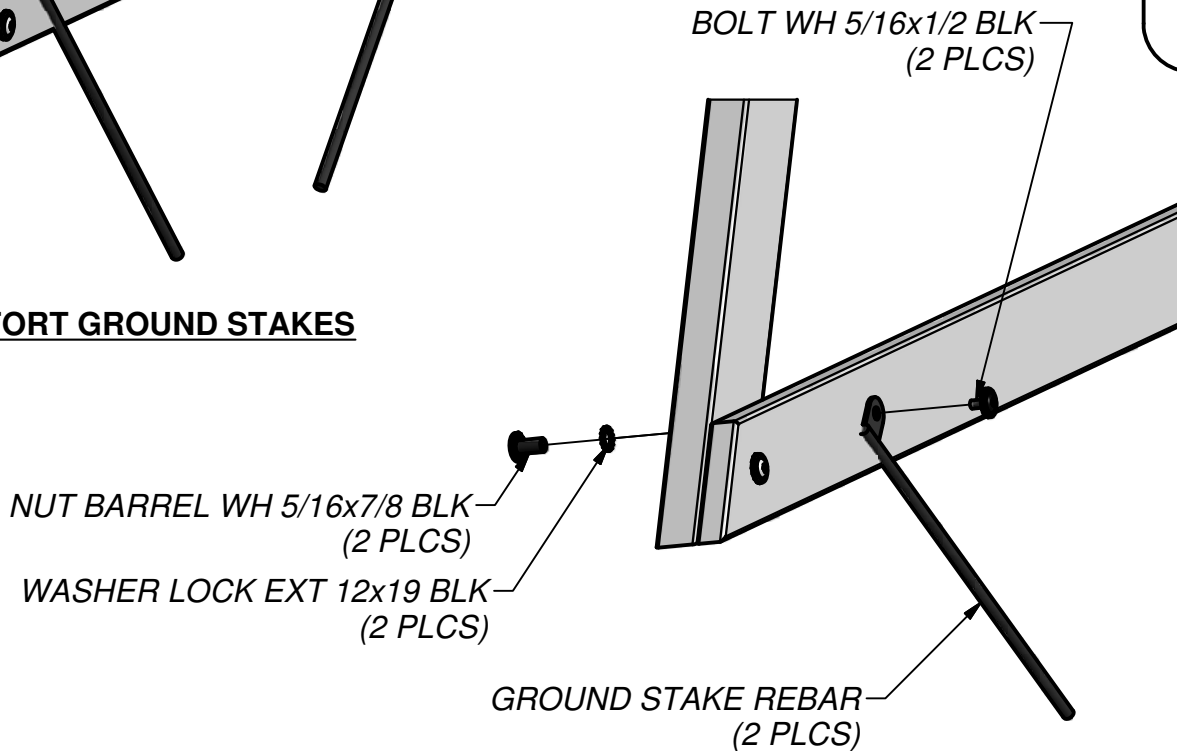

FINAL STEP

SWING BEAM GROUND STAKES

DOUBLE CHECK EVERY BOLT, SCREW AND NUT FOR TIGHTNESS. MAKE SURE EVERY BOARD IS SECURE AND MAKE SURE THE PLAY SET IS LEVEL.

ENJOY YOUR NEW PLAY SET!

